

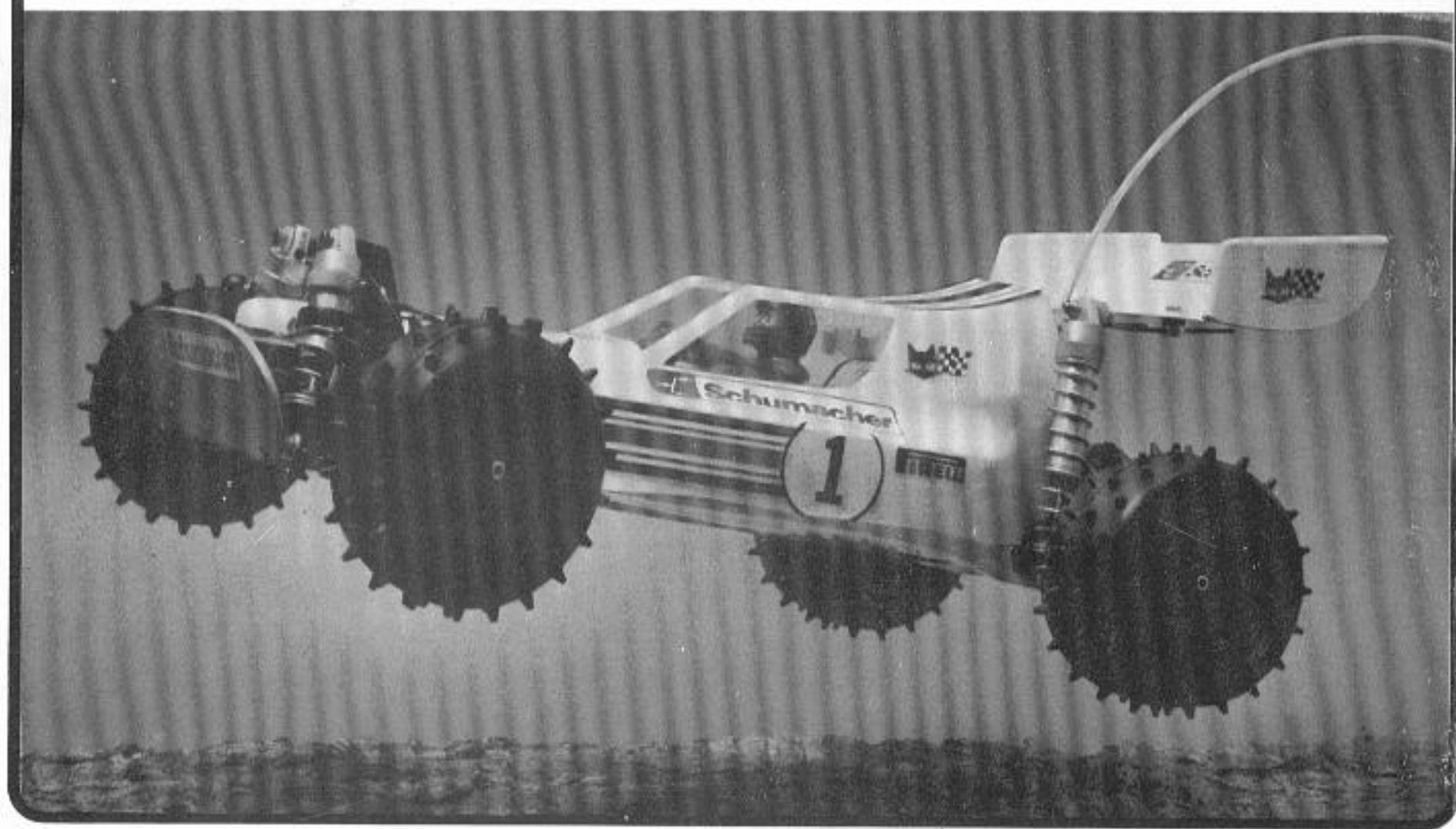

Schumacher

CAT

COMPETITION ALL TERRAIN



INSTRUCTION MANUAL

INTRODUCTION

Thank you for buying your Schumacher 'CAT' 1/10th scale off-road racing car. This is a high performance model, engineered and developed by a company with an international race winning reputation. We hope your 'CAT' will provide you with many hours of enjoyment and success on the race tracks.

Time and care spent in building the car will be rewarded with performance and reliability.

To assemble your model, please follow the photographs step-by-step whilst carefully reading the Assembly Instructions. The instruction numbers shown in the left-hand margin refer to the photograph numbers. The numbers in brackets on the photographs indicate the bag in the kit where each part may be found.

To avoid confusion, please keep the parts in their correct bags until you actually need to assemble them. The 'Operating Instructions' deal with routine maintenance and adjustments that can be made to the finished model to improve its performance and keep it in top condition.

Page(15)lists all major items (T500 numbers) in the kit. These are fully described on page(15-17). The individual items are shown in column (3) under 'Part No.'; these are available as spare parts in the assemblies shown in column (2) under 'Spares No.'

Regular bulletins will be issued containing race winning hints and tips and all the latest extras for your 'CAT'. Free copies of these will be available from your local dealer or send a stamped addressed envelope to Schumacher.

TOOLS REQUIRED FOR ASSEMBLY

Universal joint assembly tool)
Hexagon socket wrench 2.5mm) Supplied
Hexagon socket wrench 1.5mm)
Screwdriver
Spanner 5.5mm A/F
Spanner 1/4" A/F
Hacksaw (small)
Drill (for holes in bodyshell & covers)
Circlip pliers (see photograph 68)
Soldering iron
Pliers
Vice
Sharp knife
File
Pointed nose pliers or cutters

MATERIALS REQUIRED

Threadlock and superglue
Solder
Multigrade oil for shock absorbers
Polycarbonate paint for bodyshell
Motor, batteries, radio control equipment,
speed controller

SCREW IDENTIFICATION CHART

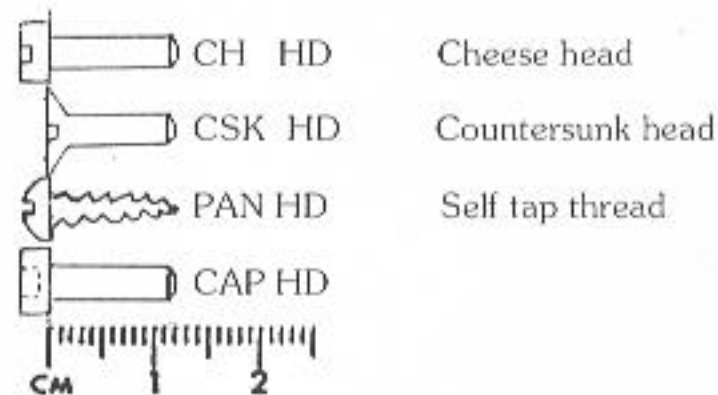

'C A T' ASSEMBLY INSTRUCTIONS

All sprues and burrs on components should be removed with a sharp knife or file before assembly.

- 1-7 These photographs identify the components on the major mouldings in the kit. Follow the photographs step-by-step taking note of the following comments.
- 8 Fix the TO81 eccentric bearing housing with only two screws as shown in photograph (22) because it will need to be adjusted later.
- 9 Bearing A530 fits inside as shown.
- 10 See comment (8) above.
- 11 Press pulley side washers onto pulleys and assemble parts onto differential shaft in the order shown. The A401 pin, the TO85 shaft and TO35 pulley may be permanently glued together. Make sure the A500 ball cage spins freely on shaft. Fit together the drive teeth of the other pulley and TO87 washer carrier and make sure the shaft is free. Use 1/8" diameter drill if tight and re-assemble in same angular position.

- 13 Superglue A221 thrust washers to TO87/TO88 thrust washer carriers. Complete assembly of differential in the order shown. Note : The A510 bearing does not fully locate in the T124 gear. Use T131 universal joint assembly tool to hold pulley whilst tightening the nut. Do not over-tighten.
- 14 Tighten the differential nut until, when the two small pulleys are held stationary, the gear is just tight.
- 16 A051 nyloc nut fits into TO31 rear hubs and must be pulled into the hexagonal recess. Screw the nyloc nut onto the end of a stud; it can then be pulled into the hub by running another nut along the stud. A washer will protect the drive teeth from damage. Also pull nyloc nuts into the four TO30 wheel hubs, photograph (5), in the same manner.
- 17 Trial assemble the integrator parts in the order shown. Superglue the A220 thrust washers to the TO32 side pulleys.
- 18 Do not overtighten at this stage, just ensure that washers are centrally located on the pulleys and that the assembly works with a smooth, free action. Now dismantle ready for fitting to the side plates.
- 19 First place the integrator shaft and rear hub in position, then assemble the first pulley, making sure drive teeth fully engage, and the first short drive belt, before the remaining pulleys and second drive belt. Before each pulley is assembled, check that the washers are securely glued in position. Screw axle into complete and fit one screw as in photograph (22) to retain the aluminium cover plate.
- 23-25 These show the pressing of the A541 one-way clutch into the TO31 front hubs. Assemble the components into a vice as shown and press the one-way clutch in. The TO86 front axle acts to keep the components square and, when the vice becomes tight on this, it should be removed. The clutch is pressed in only until it reaches the shoulder in the front hub (not flush).
Note : The one-way clutches should be the opposite way round so that the writing is showing on the end of one and not the other, as shown in photograph (25).
- 26 Push TO86 front axle into TO34 pulley, making sure pin A402 is seated in bottom of slot.
- 29 Rotate front transmission housings until they are at 90° to each other to insert the T128 drive belt.
- 30 The front hubs should be assembled so that they are free to turn in the forwards direction. Swap them around if this is not the case. Firmly tighten A052 screws, photograph (29), whilst holding pulley.
- 31 These brackets join the two chassis plates and also clamp the TO55 front transmission housing. The A214 bumper spacers fit between the lower chassis plate and the bumper (not shown) which may be fitted at this stage.
- 34 Before the TO71 outer rear transmission housing is fitted, the belt tension should be adjusted. See "Operating Instructions" (4). The point on the TO81 eccentric bearing housing corresponds to the point of minimum clearance i.e. if this point faces the differential shaft, then the belts are at their slackest. Both bearing housings should be at the same setting. Remove the housing screws and rotate the housings until the correct tension on the T129 short drive belts is obtained. To adjust the tension of the T128 long drive belt, slacken the eight screws holding the TO56/TO57 front brackets and slide the front transmission housing. After adjustment, fit the remaining two A301 self-tapping screws into TO81 bearing housings. Retain the TO71 outer rear transmission housing with the two A323 screws only, as shown.
- 35 The ends of all the pivot pins require deburring before assembly. The pins should be inserted in the smaller of the two holes in the TO77, lower rear suspension pivots.
- 37 Make sure top wishbones fit freely over TO79 pivots. Put in screw A326 before pin to make assembly easier.
- 38 Wishbones are identified 'A' or 'B' and should be fitted as shown. Fully assemble TO45 ball pivot to A092 stud using thread lock to secure, and assemble to upper pivot TO79 as in photograph (65); stud end should be well below ball surface.
- 39 Shows fitting of rear shock bracket.
- 40-42 Shows assembly of front pivot bracket and lower wishbone.
- 43 Bend the A411 swivel pin neatly and accurately as shown (see template).
- 44 Run the A090 stud right to the end of the thread in the TO45 pivot ball and secure with thread lock before fitting to the wishbone; make sure stud is below ball surface.
- 45 Make sure T109 top wishbone swings freely on TO58 arm before fitting A410 pivot pin.

- 46 File the sharp corners from the mouth of the T131 universal joint assembly tool. Before assembly, secure the pin in the T108 universal joint with superglue in the centre only.
- 47-56 These photographs show the procedure for assembling the drive shafts, hubs and universal joint pivot assemblies (T515).
Note — In photograph (47) the universal joint pivot assembly is pushed in from the side to start, using the spherical surface to part the lugs. After photograph (55), use the universal joint assembly tool as in photographs (49 - 51).
- 57 Repeat this for rear of car.
- 58 Shows assembly of TO45 pivot balls into the front and rear hub carriers. Note: The steering control balls are towards the rear of the car. Similarly, the rear track control balls are towards the rear. This makes a left and right assembly of each. Spacer washer A206 is fitted under steering pivot ball. See also "Operating Instructions" (5). The front upper pivot retaining screw needs a small flat filing on the side of the head which prevents the screw from rotating. Use the hexagon of the ball joint to tighten. Two T530 bearings are placed in each hub carrier, one from each side. The upper wishbone pivots are retained by A012 8mm screws and the remaining pivots by A013 10mm screws.
- 59-60 Assemble bearings and drive shafts as shown.
- 61 Spring wishbones into position before fitting A304 clamp screws; tighten to take out excessive clearance. Carefully file small amounts of material from wishbones to allow full steering movement at extremes of suspension movement.
- 62-63 Centre track rod assembly. Note: TO98 lever can be assembled either side of the car and in a variety of positions. Lock screws tight to fibreglass allowing sufficient clearance for levers to move freely. Apply thread lock to pivot ball and all threads.
- 65-66 Set rear track rods at approximately 54mm between ball centres, (62mm overall) and front at 63mm between centres (71mm overall).
Refer to "Operating Instructions" paragraph (5) for bump steer correction. File a little material off the ball of the front in-board ball socket to clear the chassis at full lock.
- 67 Shows order of assembly of shock absorber seals. Note direction of lip on A170 seal and recess for wiper 'O' ring A181 in TO64 bush. Apply light oil before fitting.
- 68 Good quality circlip pliers are essential.
- 69 Deburr circlip grooves and threads on piston rod T062/T063 before assembly to avoid damage to seals. To hold the piston rod whilst screwing on the T113 rod end, file two flats on the shaft as shown in photograph (68a), then hold with a pair of cutters. Take care not to damage the main part of the piston rod as this will cause the shock absorbers to leak. Always fit the rod into the body from the bottom to avoid damaging the lip seal. Assemble TO97 piston (large notch) to the long rod for the rear shock absorber. Assemble TO96 (small notch) to the short rod for the front shock absorber. Before filling with oil ensure piston moves freely through full length of stroke, carefully relieve if necessary.
- 70 With the piston rod fully extended, fill the shock absorber with a multigrade oil. Work the piston up and down to release any trapped air. Assemble the 'O' ring seal and cap with the piston at its uppermost position. Note: The 'O' ring fits inside the cap.
- 71 Repeat this procedure for the front shock absorbers using the short piston rod, short body, short spring, short rod end and the piston with the small hole. Additionally, cut the T117 spacer tube into 6mm lengths and position over the piston rod, against the rod end. This raises the height of the TO90 spring stop. Insert spring spacers TO92-5 as required to adjust the ride height.
- 72 Fit lower shock absorber mounting screw first. Back off to allow the top to be fitted without straining the shock absorber. Tighten top shock absorber mounting. Screw to zero clearance and then slacken by one complete turn.
- 73 A188 tension band fits over lugs on TO06. Bands should be lapped several times to provide sufficient tension to firmly hold front wheels in position.
- 74 CO58 nicad clamp locates as shown, and will remain in position with nicads removed. For added convenience, saw a screwdriver slot in the ends of the A040 screws to allow operation from above and avoid the need for an access hole in the undertray.
- 75 The A090 wheel retaining screws screw into A050 M3 nyloc nuts (bag T513) which fits inside the wheel hubs. Ensure that the nuts are pulled into the hubs as in photograph (17).
- 77 Servo mounting posts.

WIRE BENDING TEMPLATES



FRONT PIVOT

ø 2mm

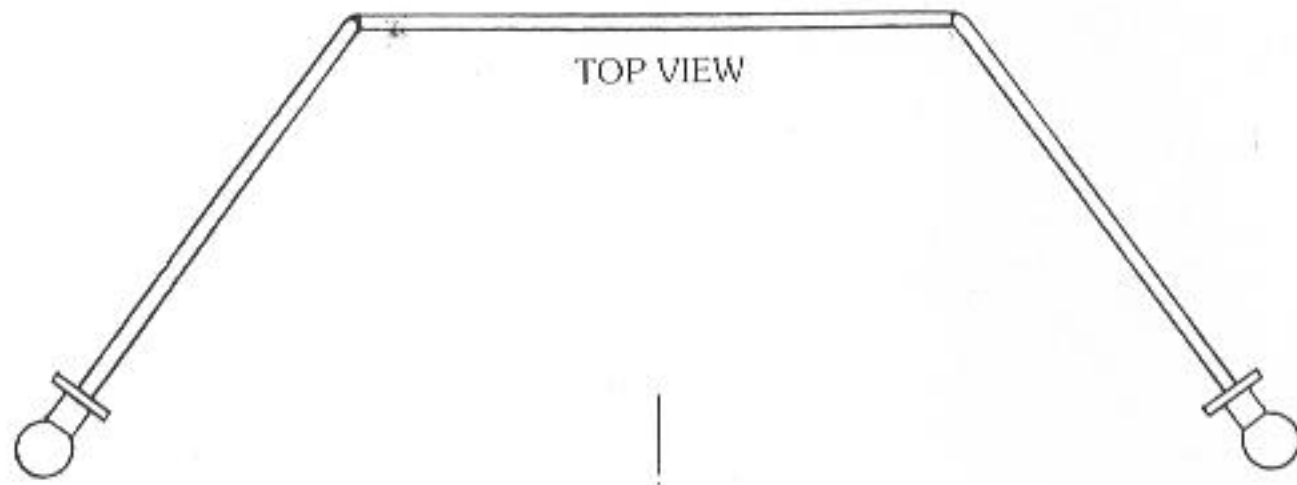

TOP VIEW

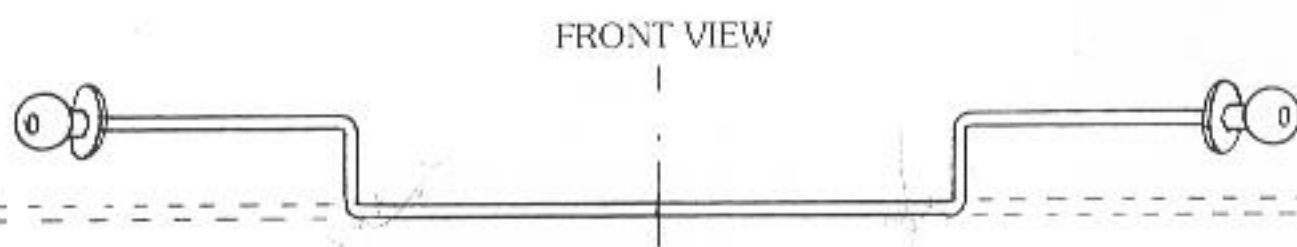

FRONT VIEW

FRONT ANTI-ROLL BAR

ø 1.6mm (16 SWG)

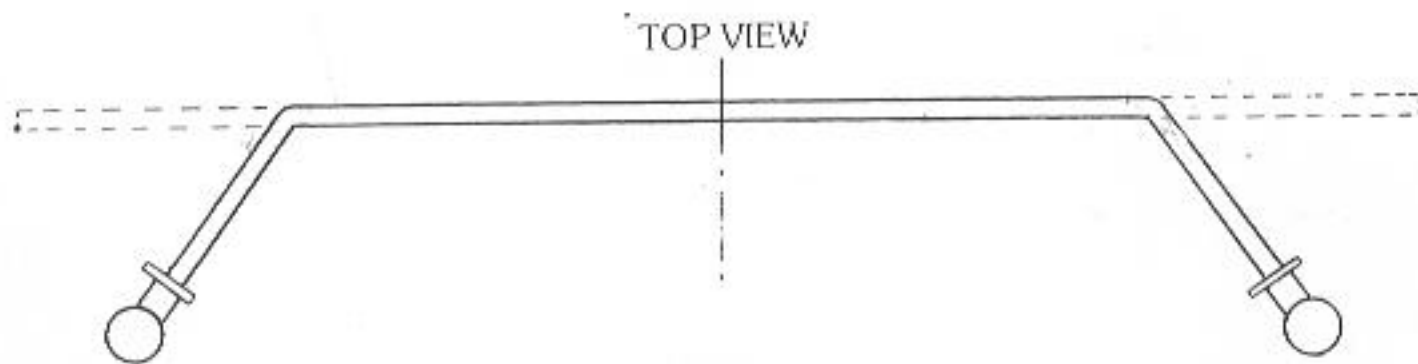

TOP VIEW

REAR ANTI-ROLL BAR

ø 1.8mm (14 SWG)

FRONT VIEW

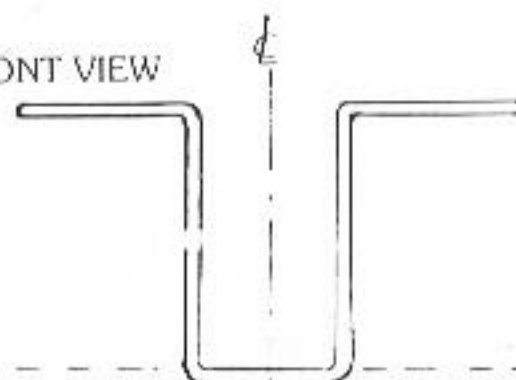

SIDE VIEW



WING MOUNT

ø 1.6mm (16 SWG)

'C A T' ASSEMBLY DIAGRAMS

T617 PULLEY MOULDING 51-50T (T519)

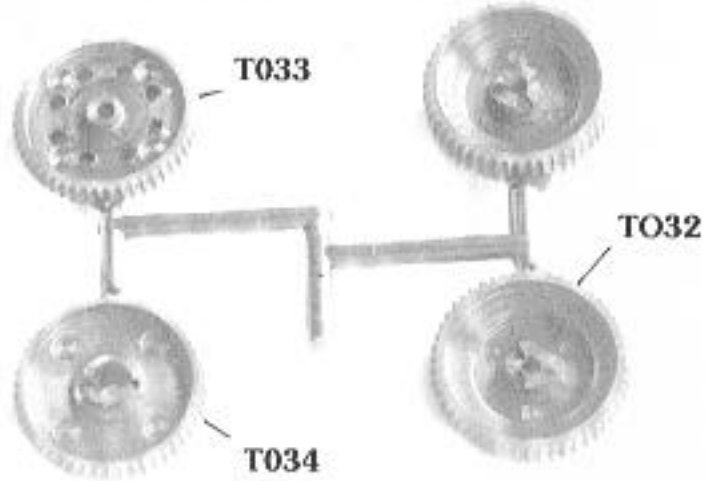

- 1 -

T618 PULLEY MOULDING 21T & BALL CAGE (T519)

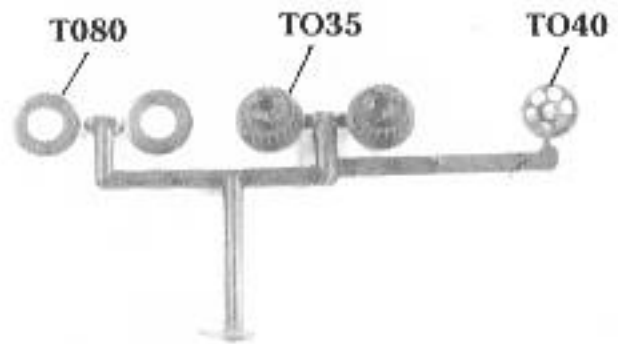

- 2 -

T613 SPRING STOPS & SPACERS MOULDING (T511)

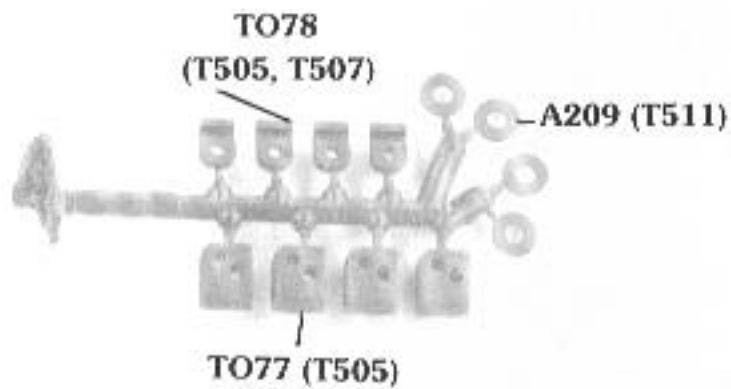

- 3 -

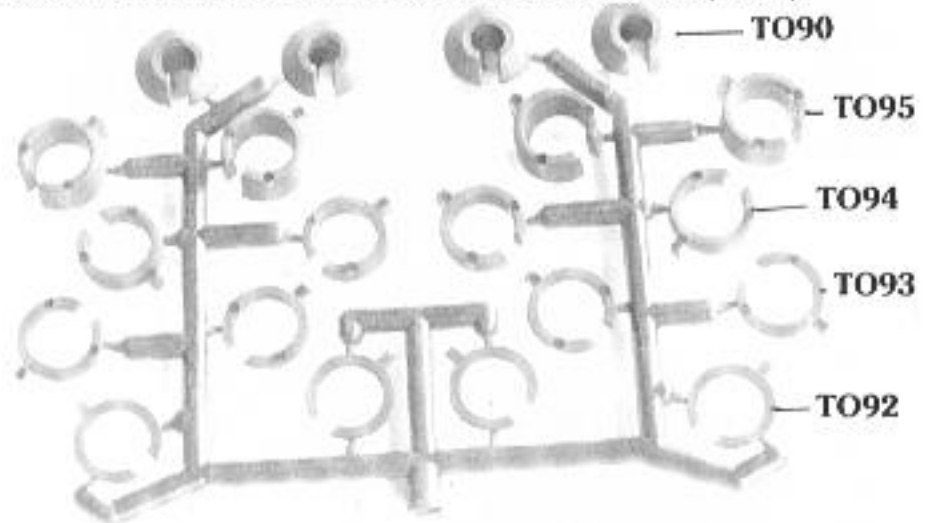

- 4 -

T612 HUB MOULDING

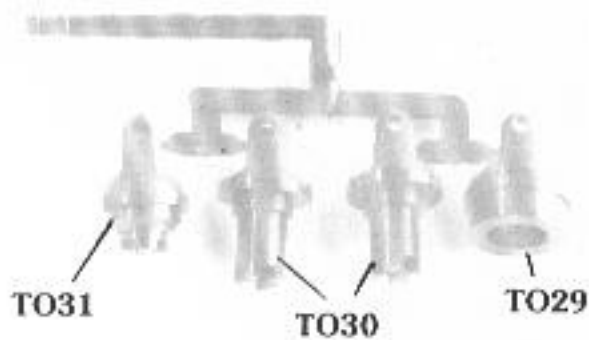

- 5 -

T518 BRACKET MOULDING

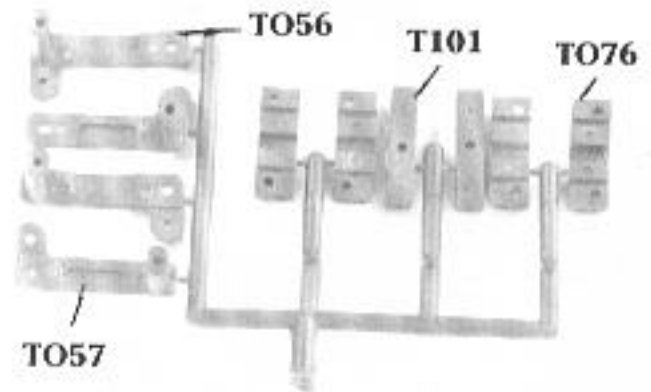

- 6 -

T517 BEARING HOUSING MOULDING

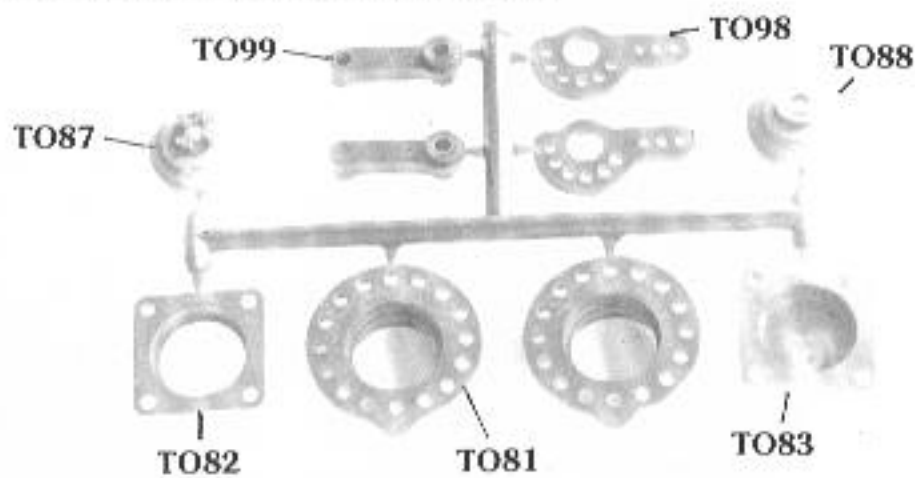

- 7 -

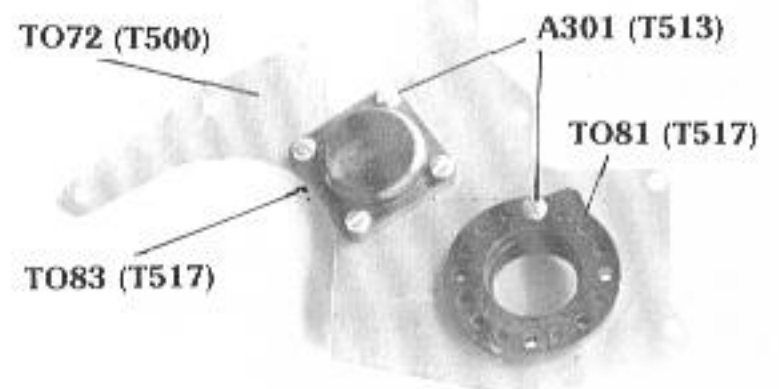

- 8 -

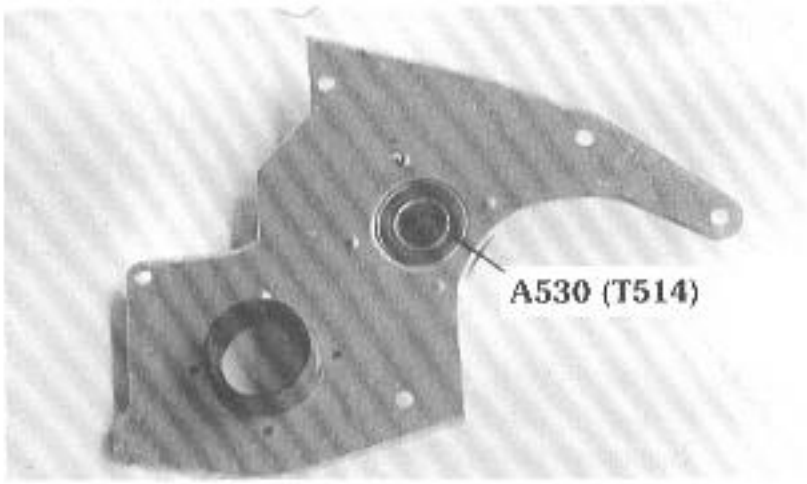

- 9 -

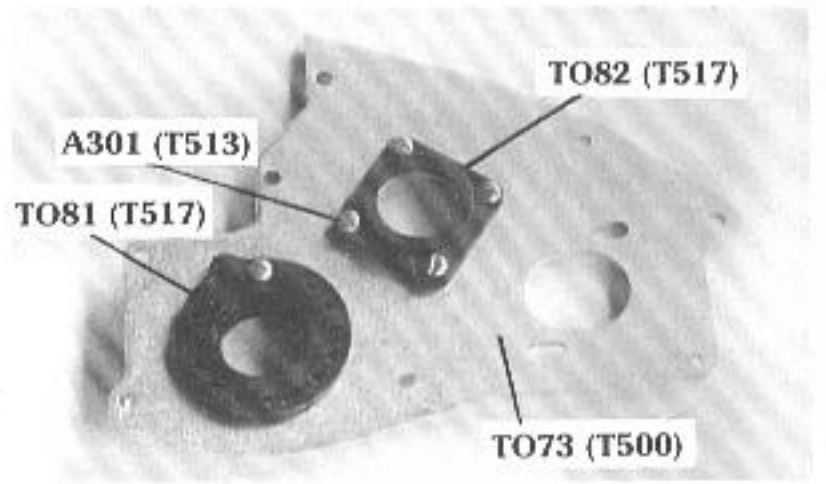

- 10 -

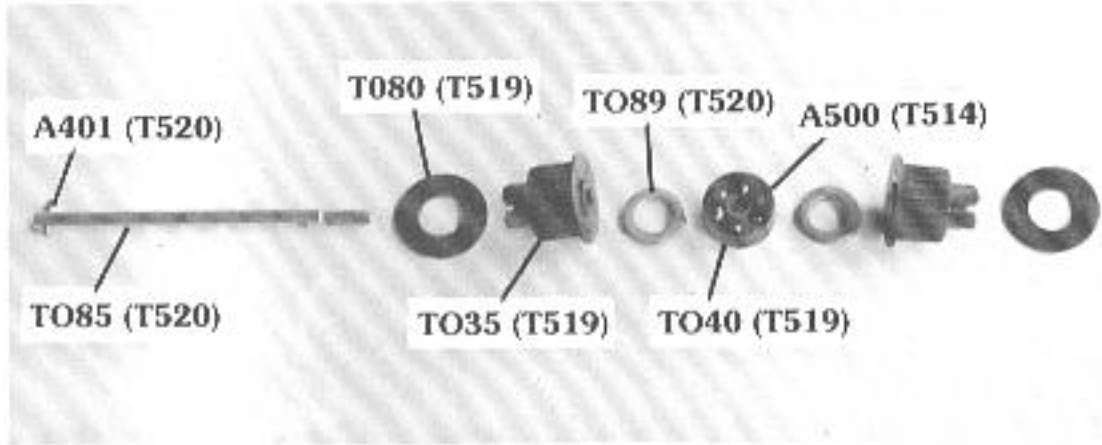

- 11 -

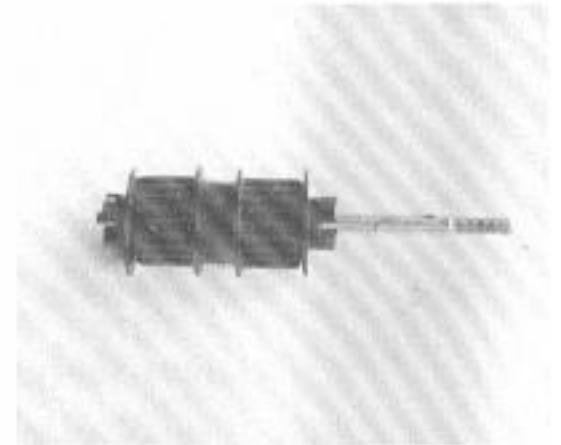

- 12 -

DIFFERENTIAL

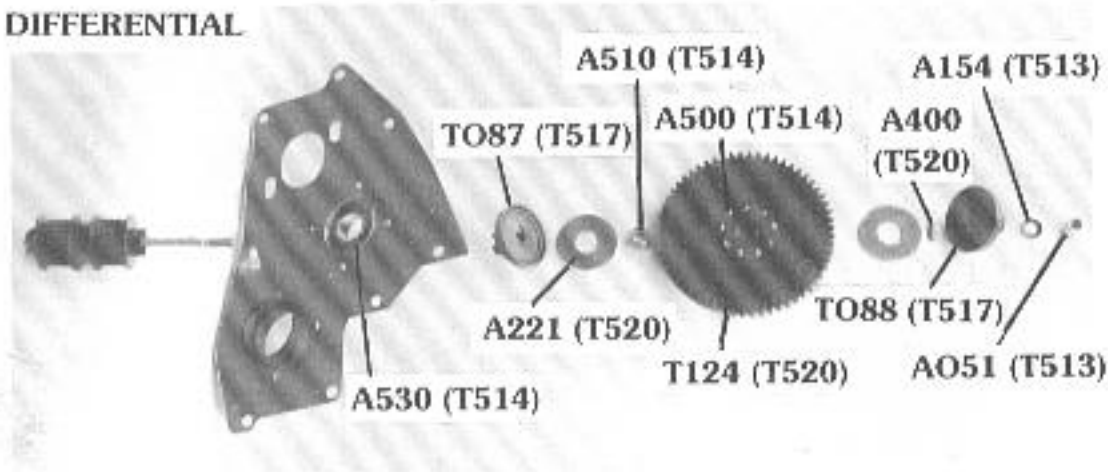

- 13 -

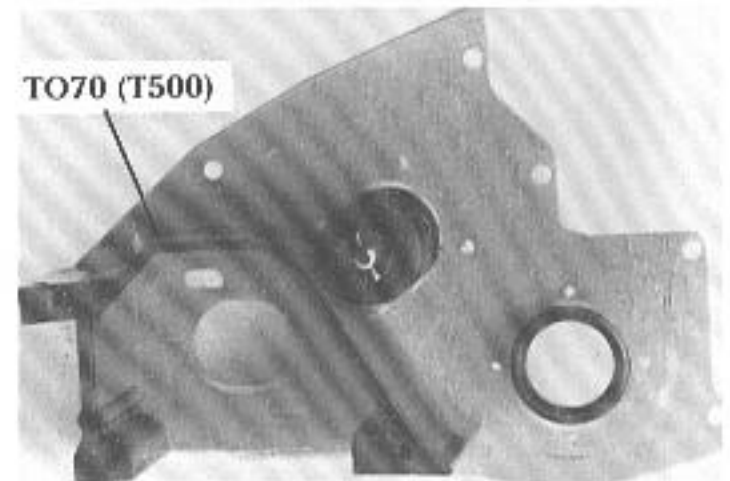

- 14 -

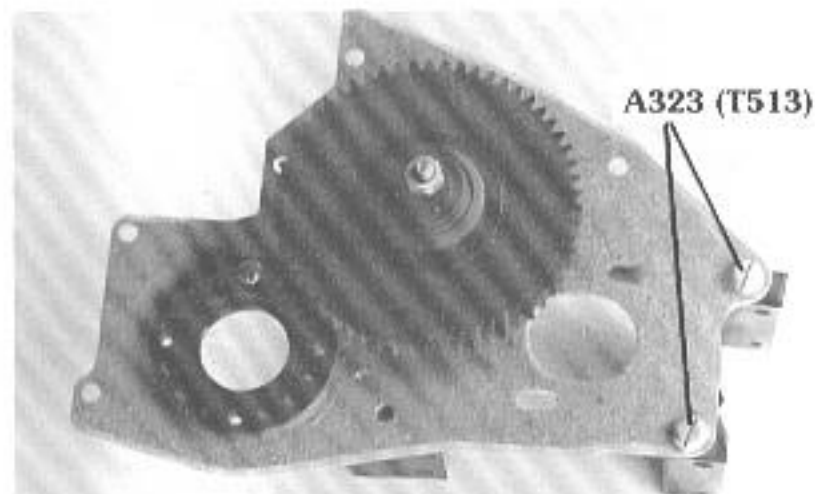

- 15 -

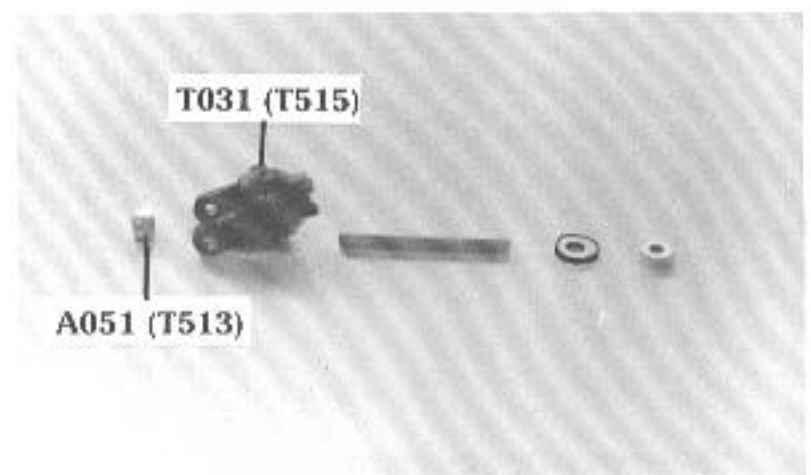

- 16 -

INTEGRATOR

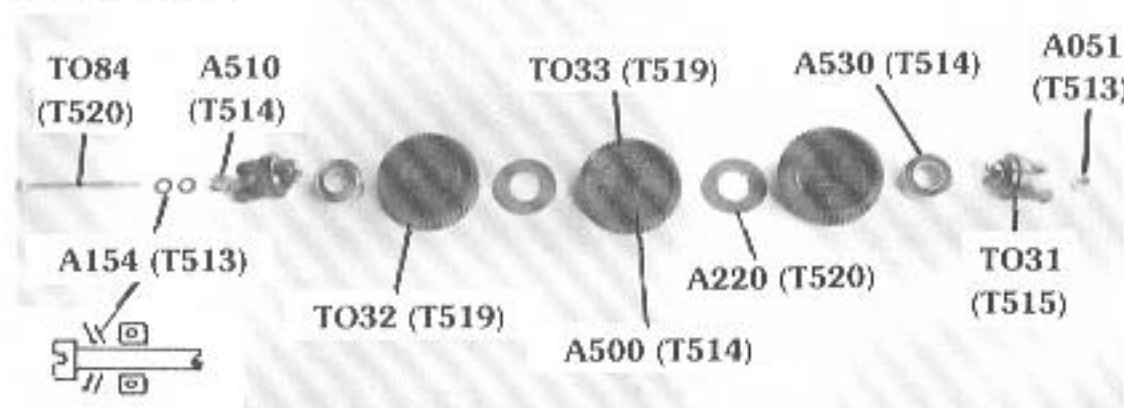

- 17 -



- 18 -

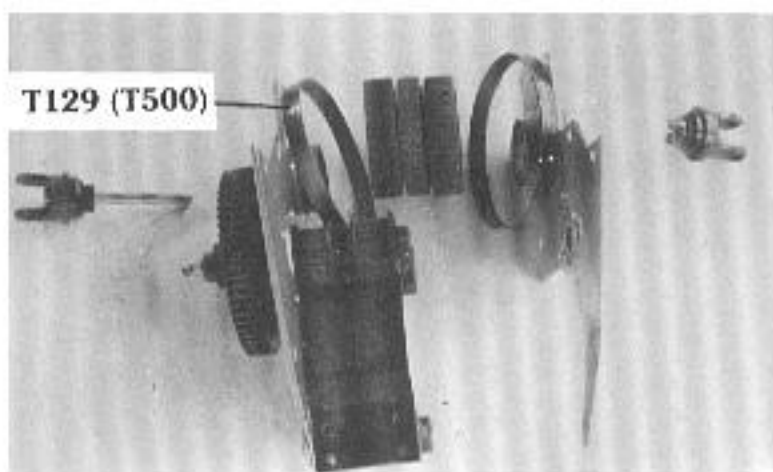

- 19 -

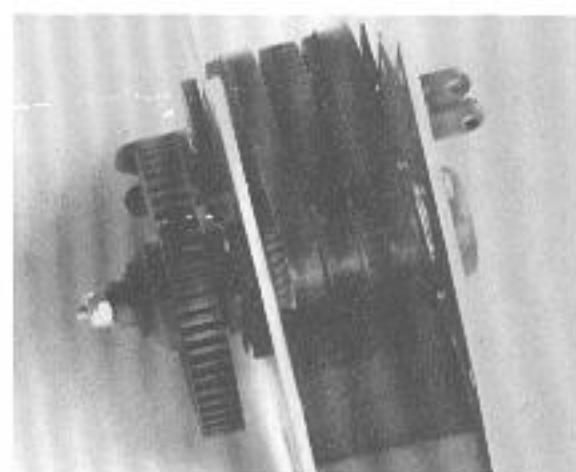

- 20 -

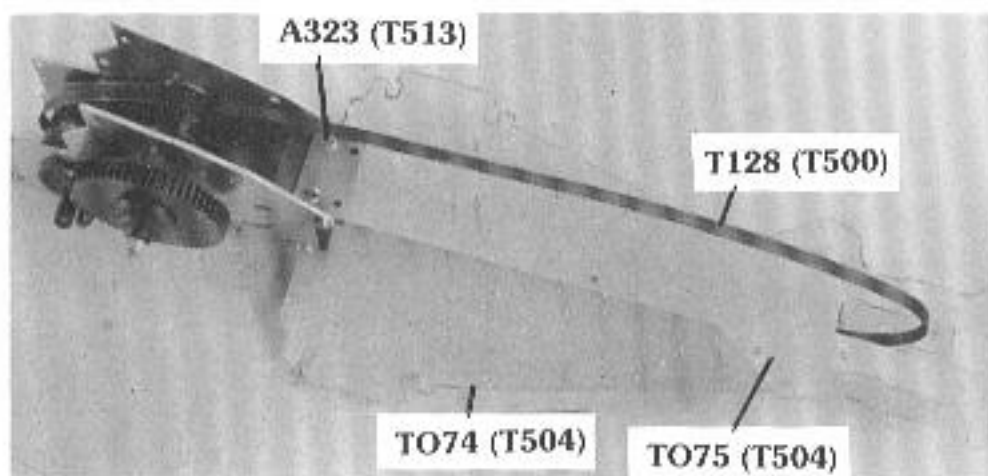

- 21 -

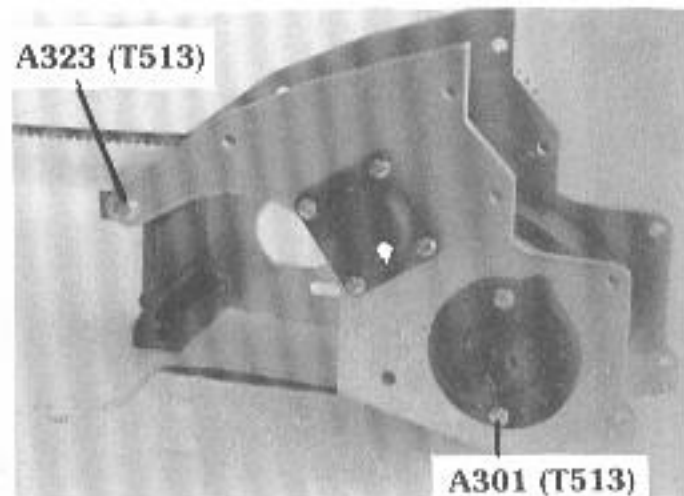

- 22 -

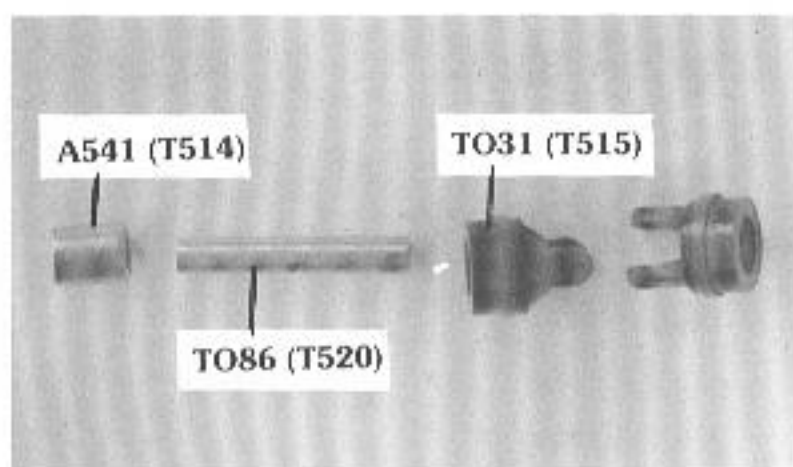

- 23 -



- 24 -

ONE WAY CLUTCHES

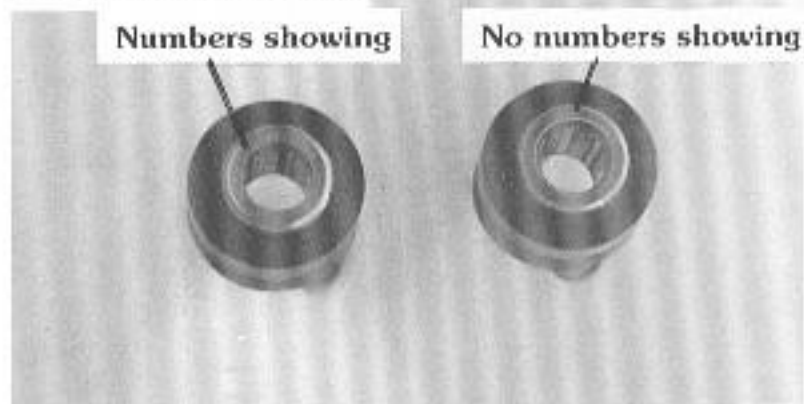

- 25 -

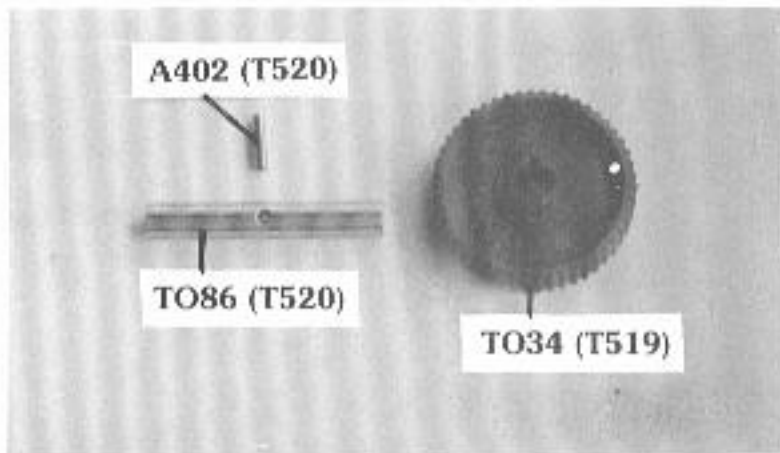

- 26 -

FRONT TRANSMISSION ASSEMBLY

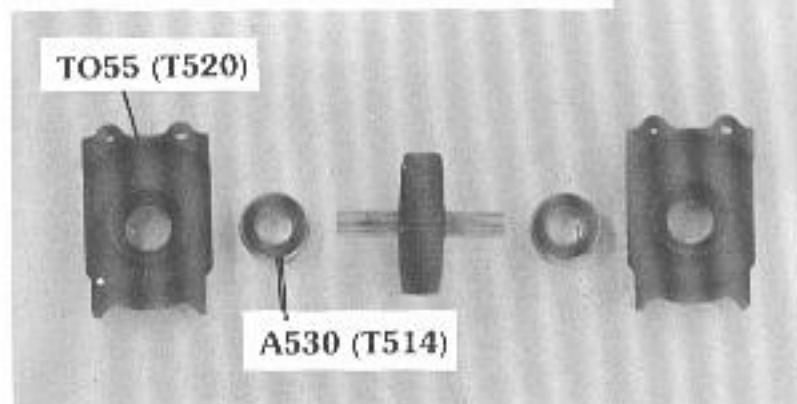

- 27 -

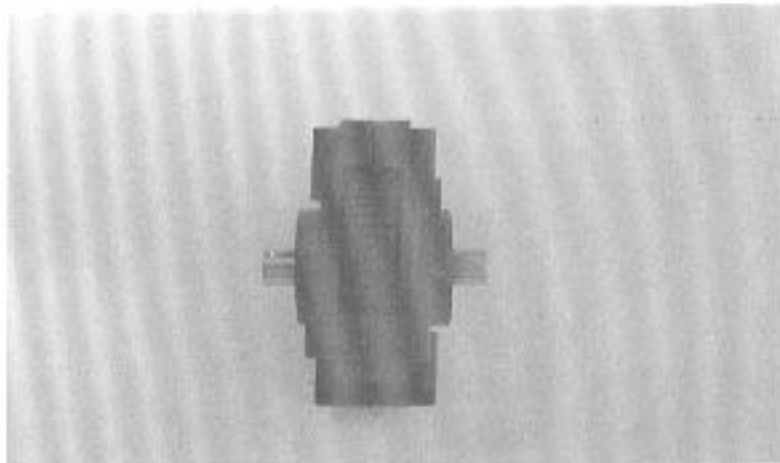

- 28 -

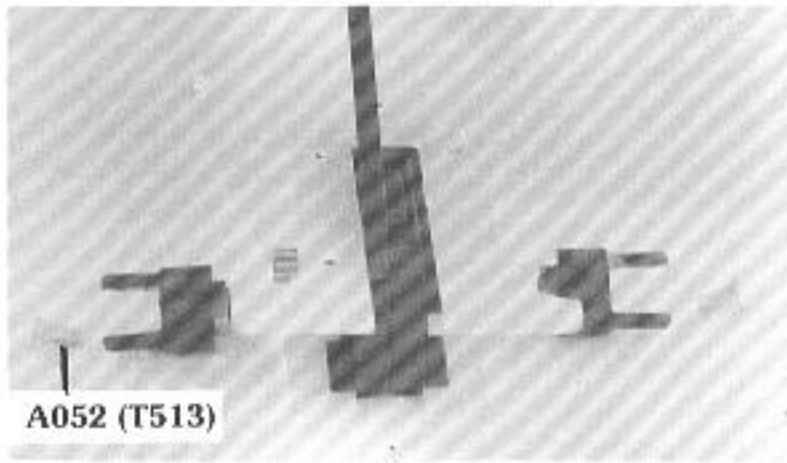

- 29 -

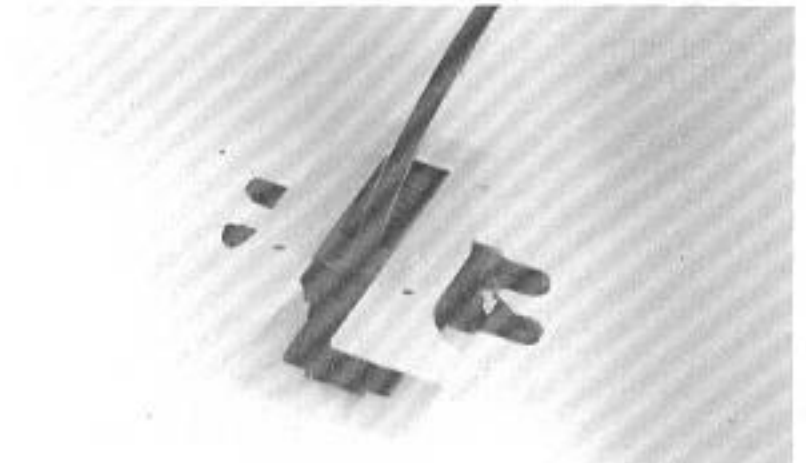

- 30 -

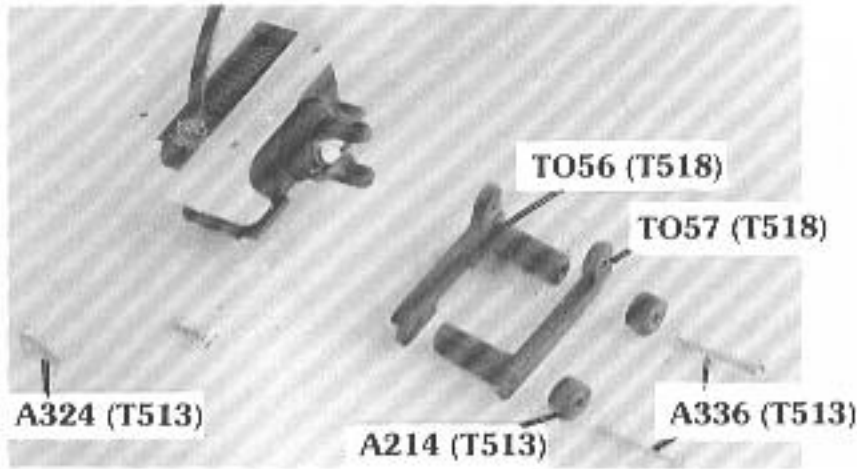

- 31 -

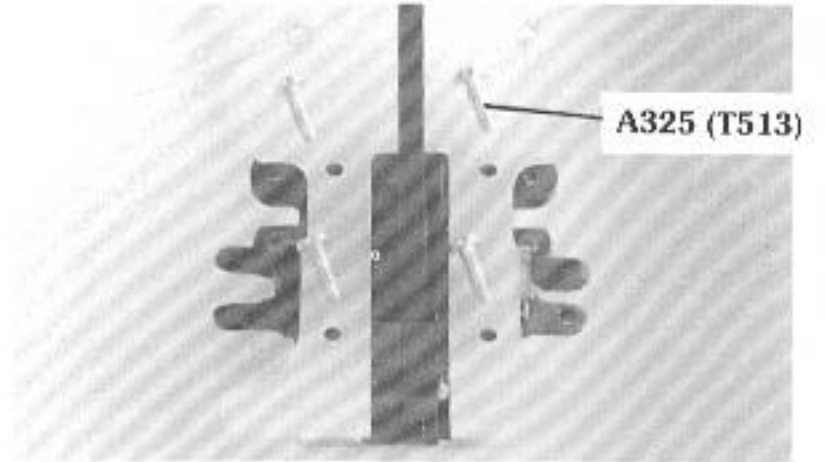

- 32 -

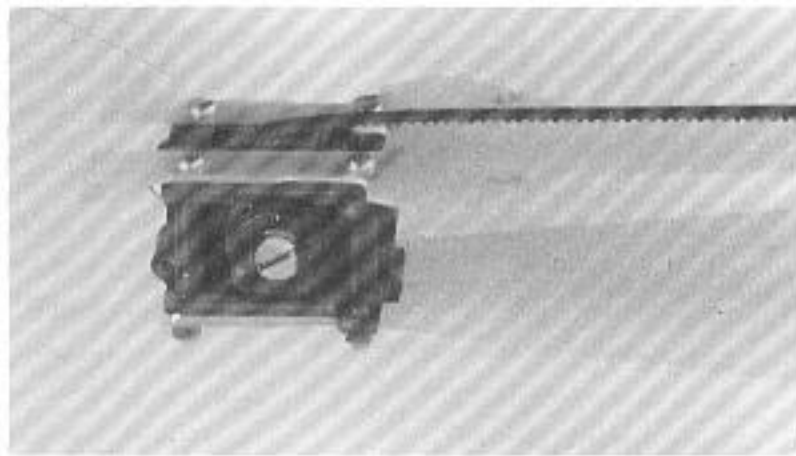

- 33 -

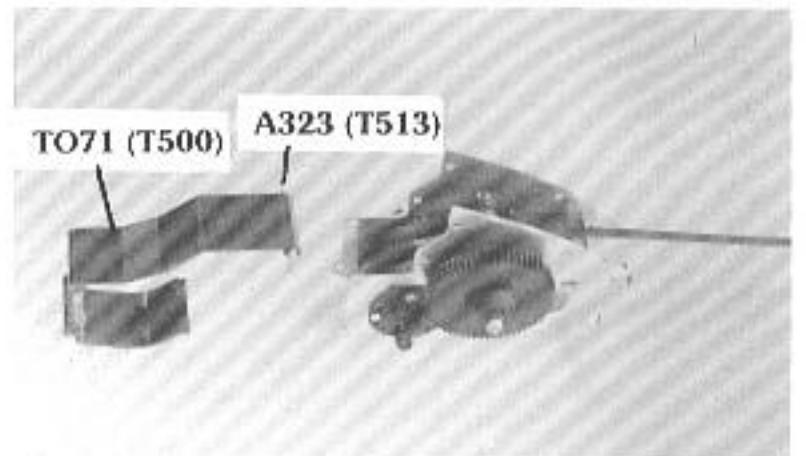

- 34 -

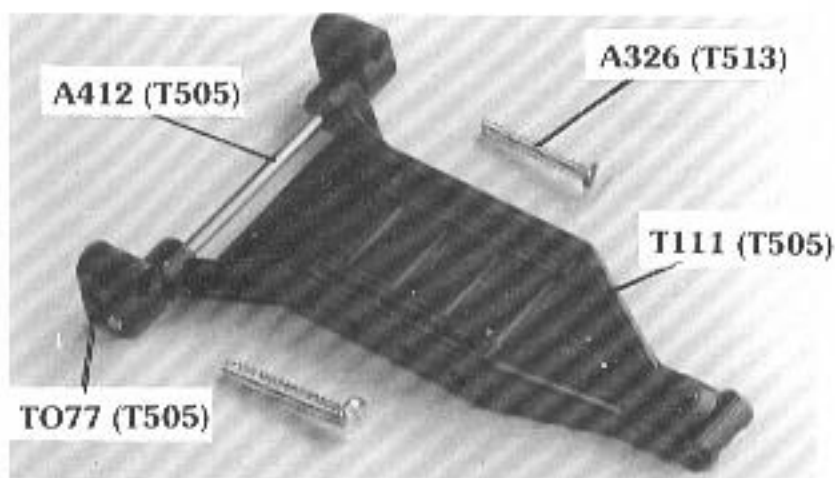

- 35 -

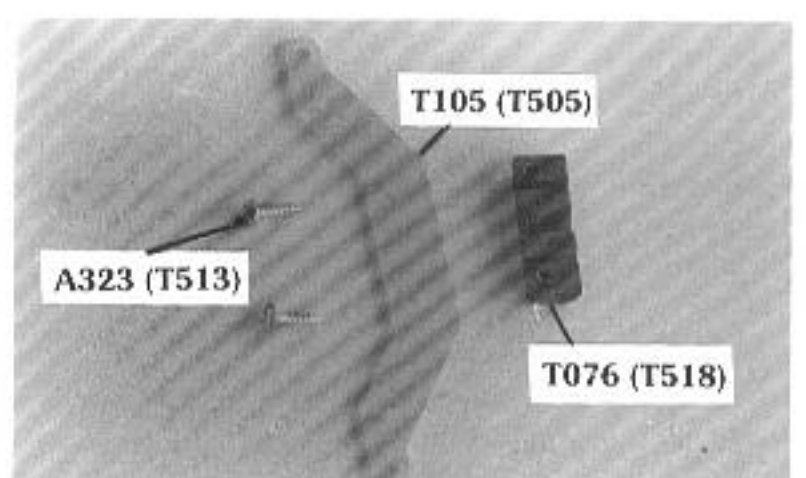

- 36 -

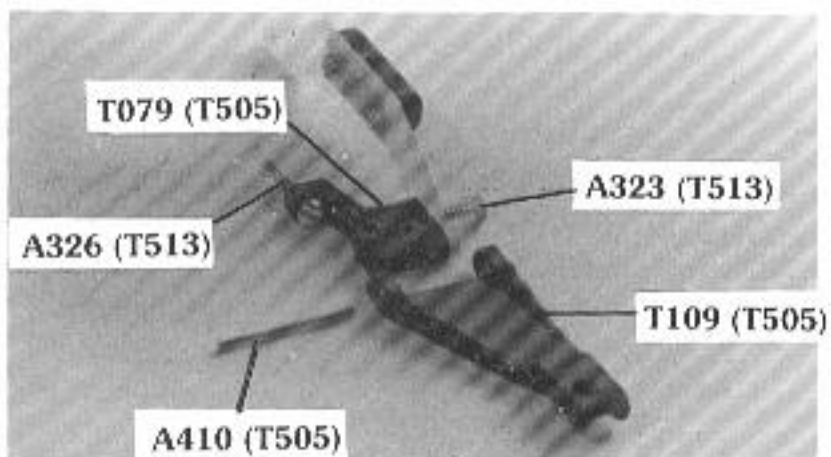

- 37 -

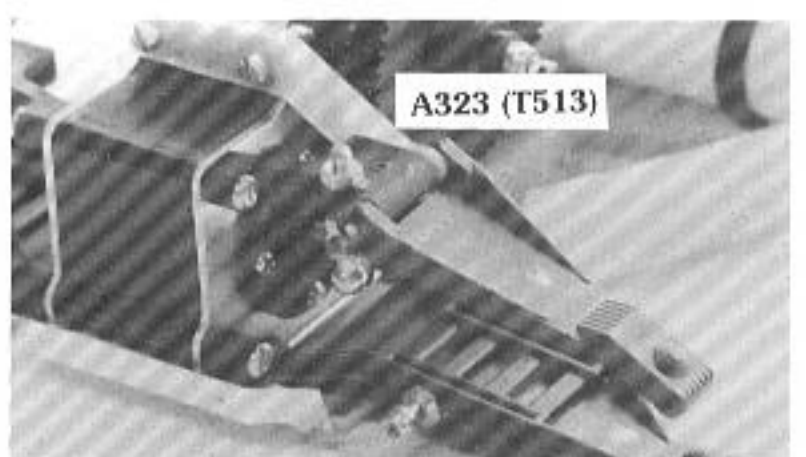

- 38 -

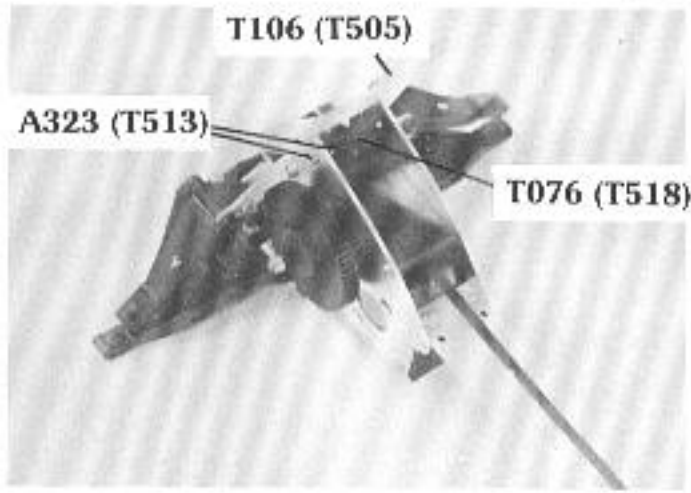

- 39 -

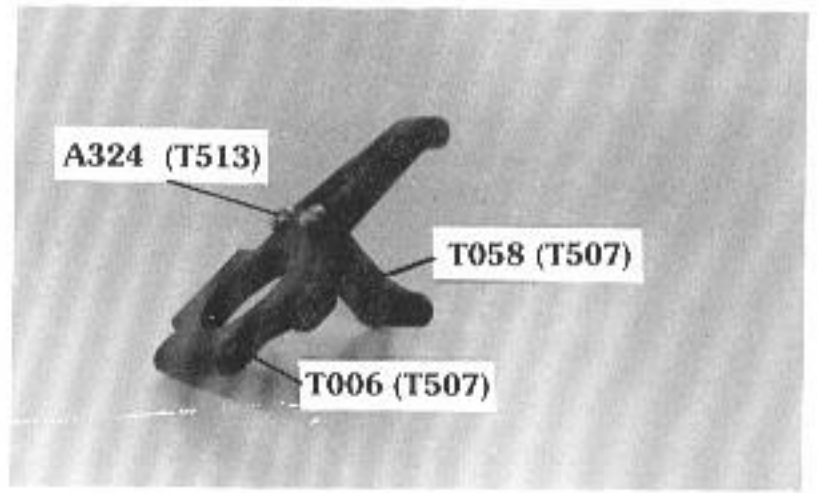

- 40 -

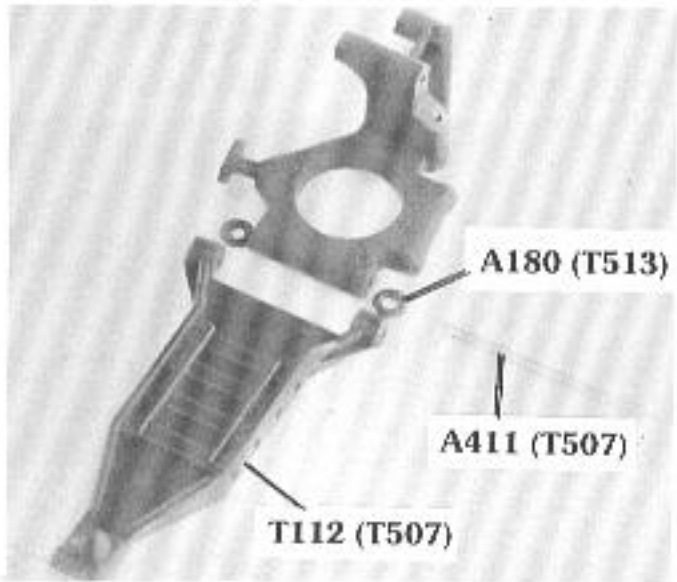

- 41 -



- 42 -

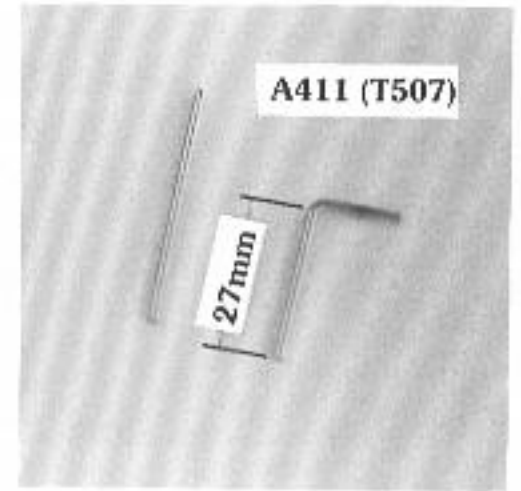

- 43 -

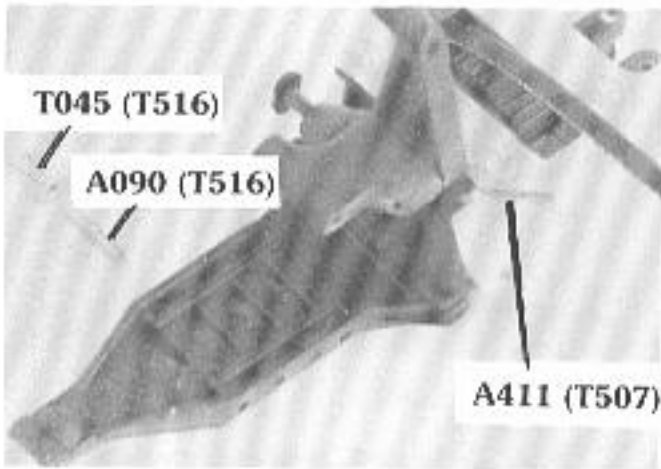

- 44 -

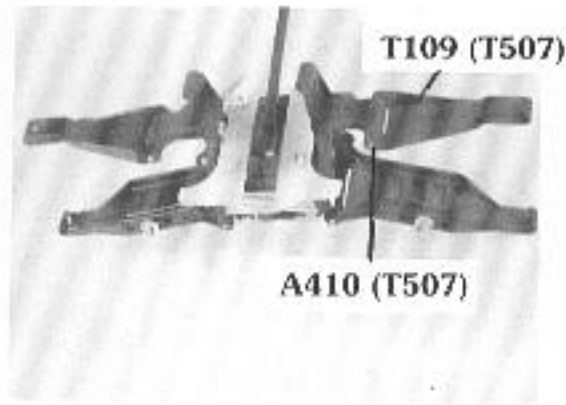

- 45 -

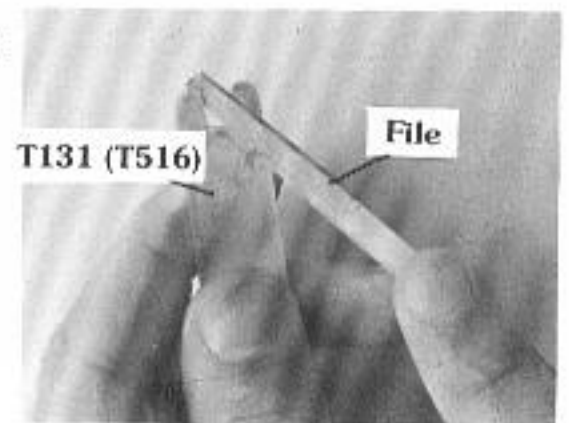

- 46 -

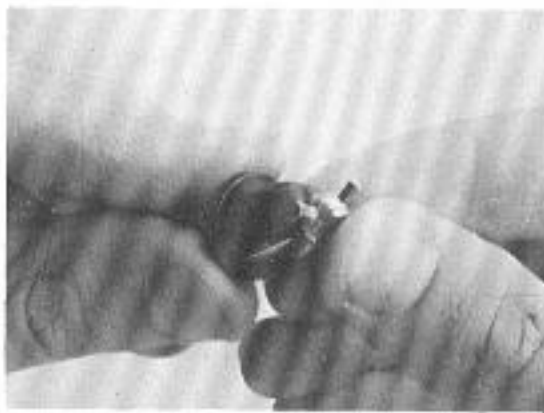

- 47 -



- 48 -

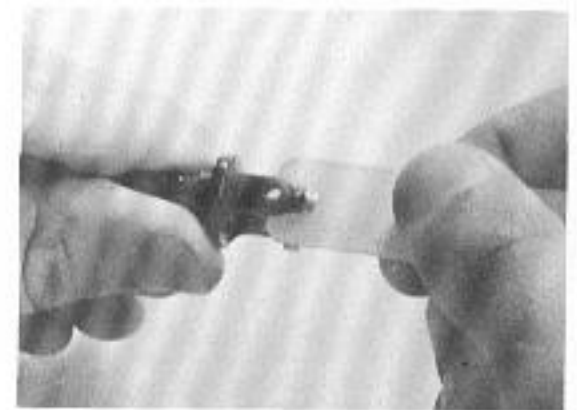

- 49 -



- 50 -

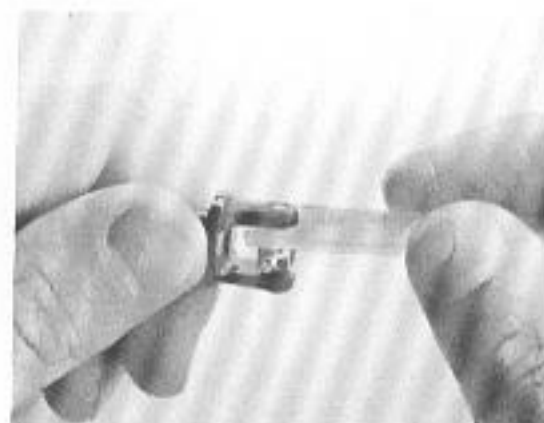

- 51 -



- 52 -

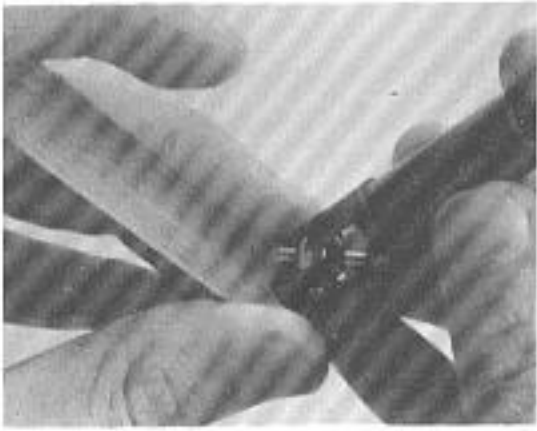

- 53 -

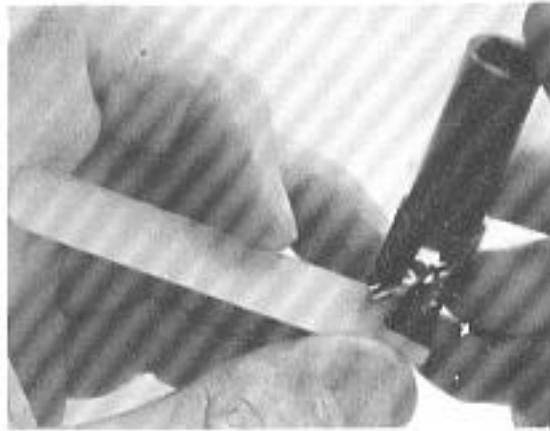

- 54 -



- 55 -

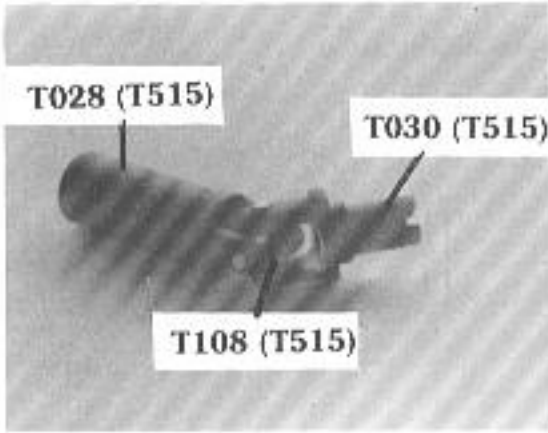

- 56 -

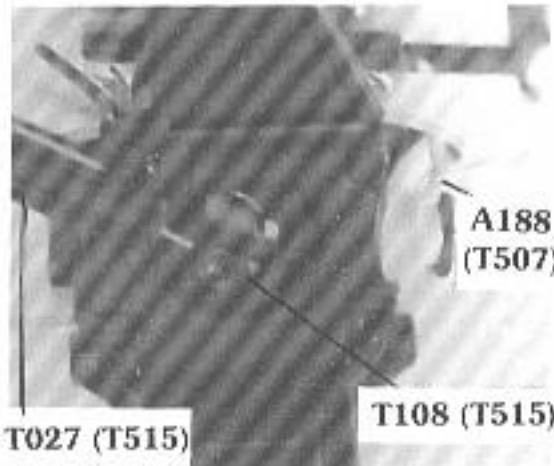

- 57 -

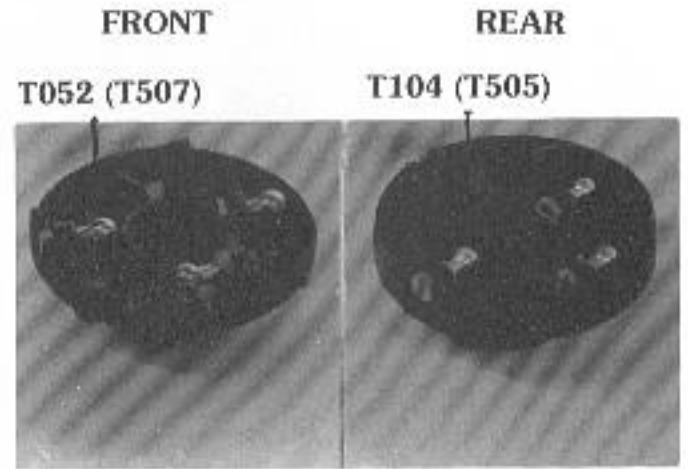

- 58 -

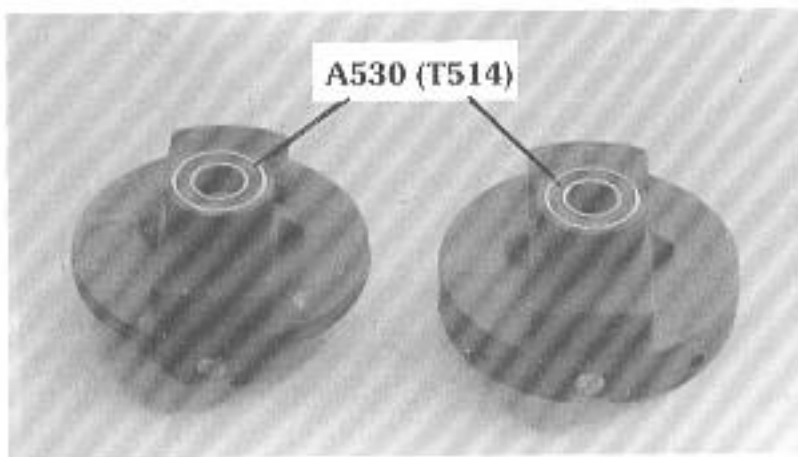

- 59 -

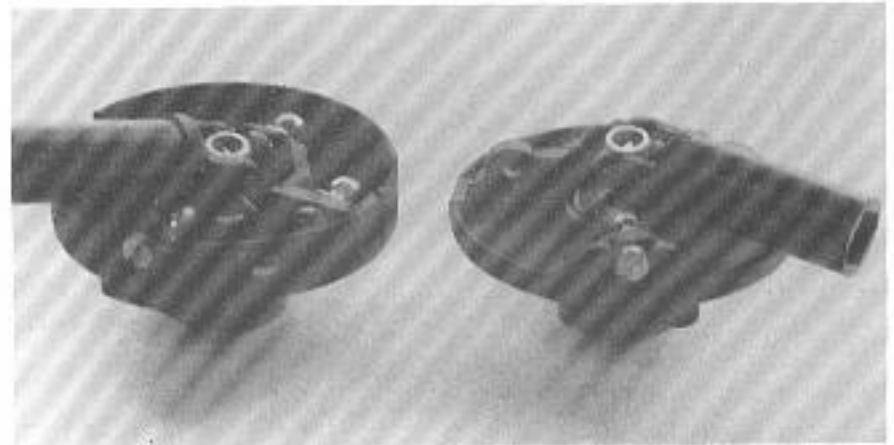

- 60 -

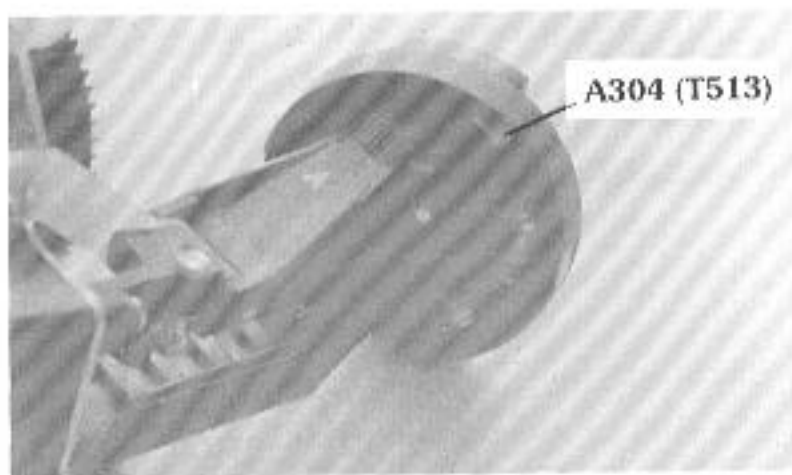

- 61 -

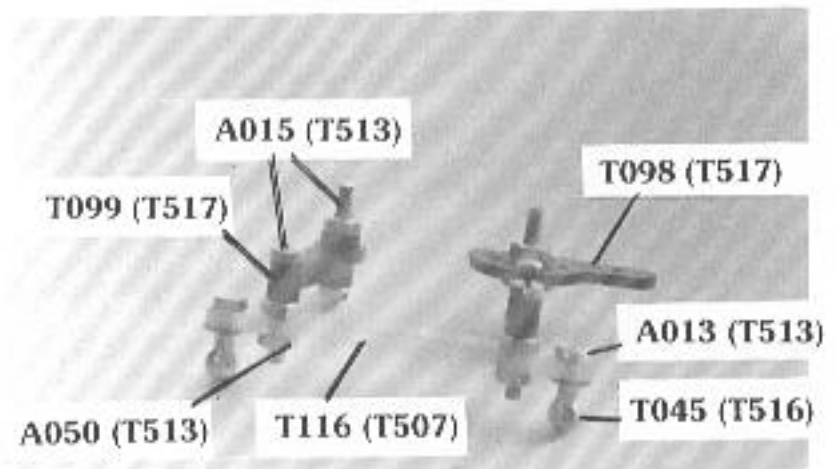

- 62 -

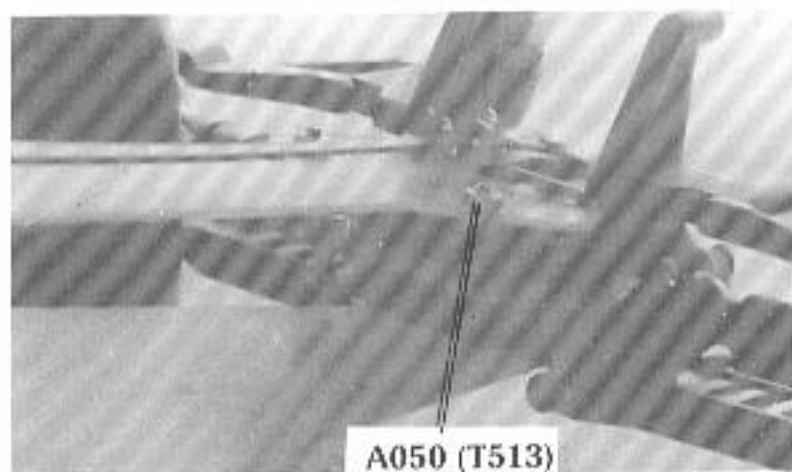

- 63 -

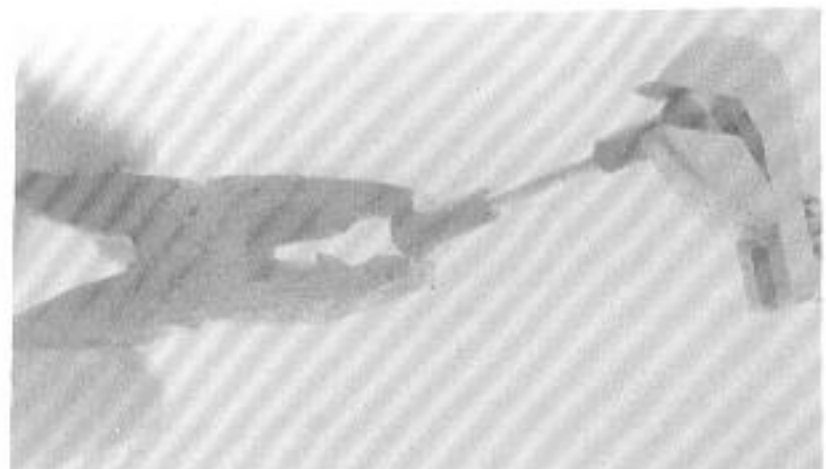

- 64 -

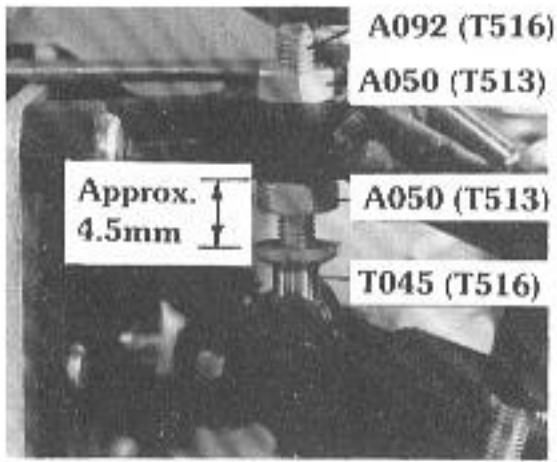

- 65 -

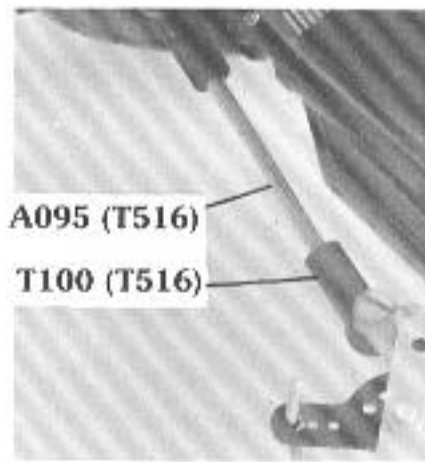

- 66 -

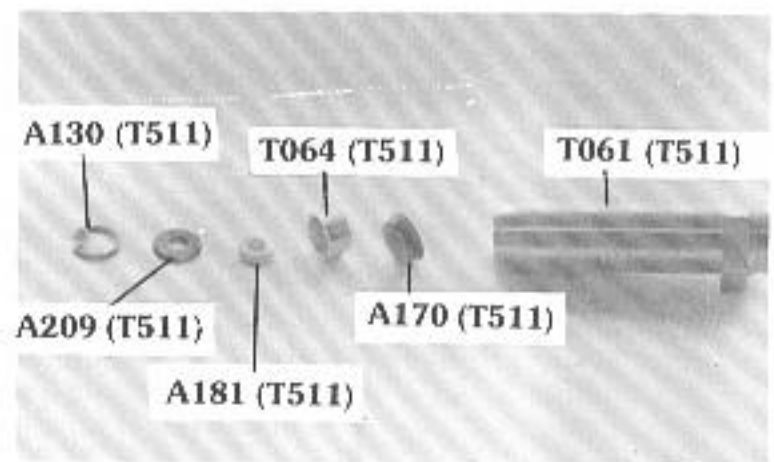

- 67 -

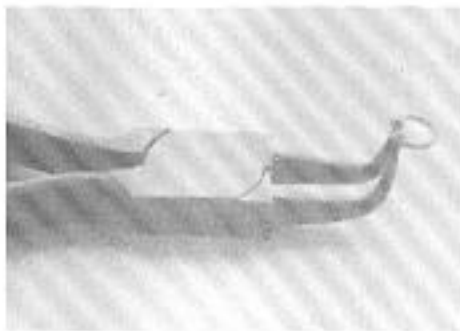

- 68 -

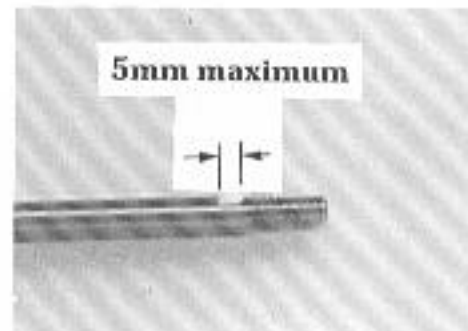

- 68a -



- 68b -

REAR SHOCK ABSORBER

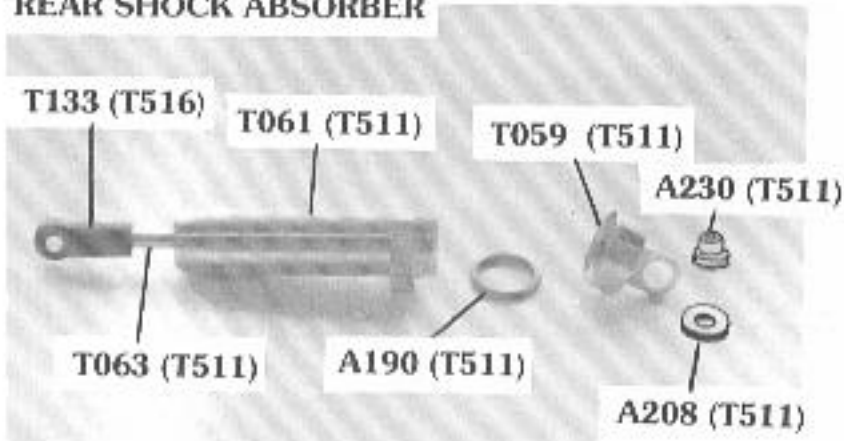

- 70 -

REAR SHOCK ABSORBER

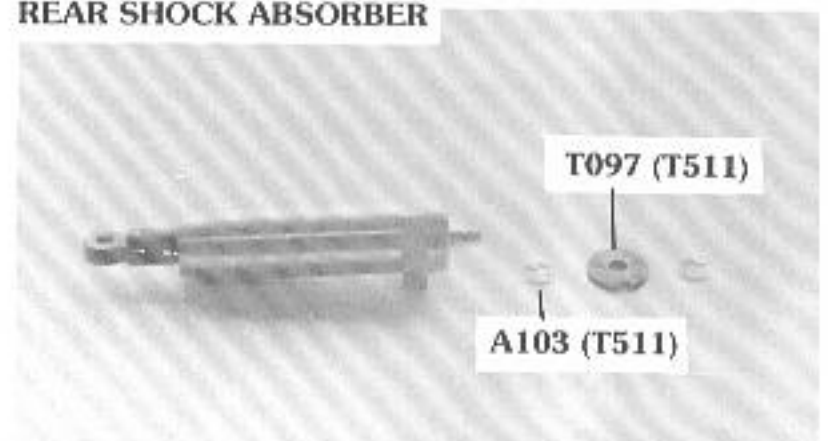

- 69 -

REAR SHOCK ABSORBER

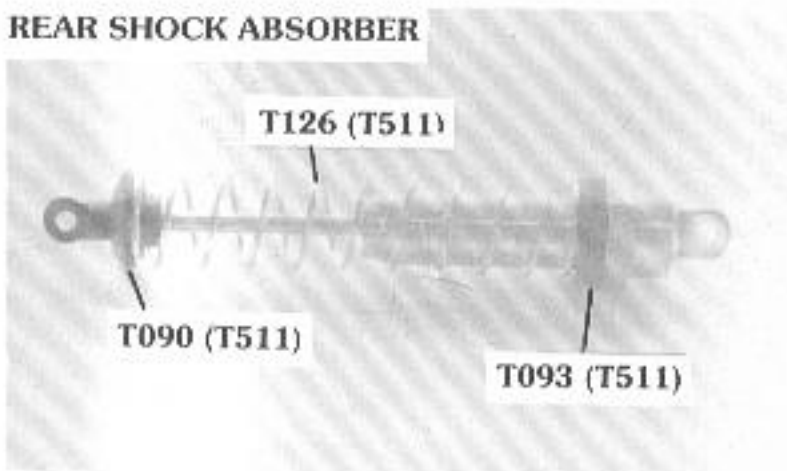

- 71 -

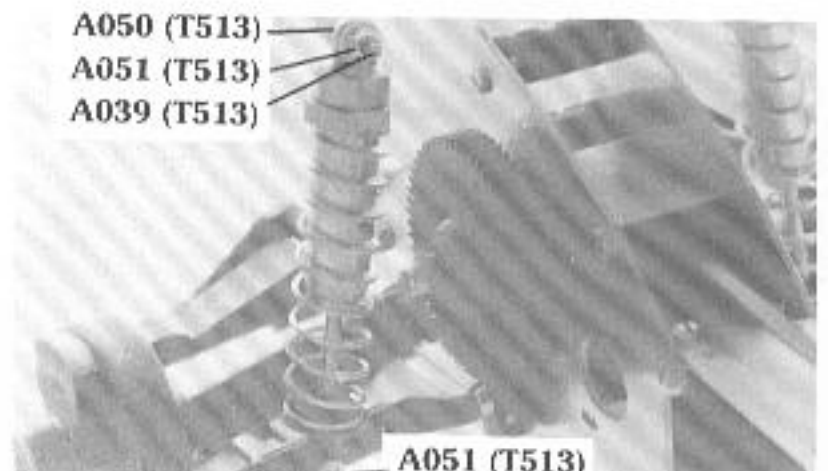

- 72 -

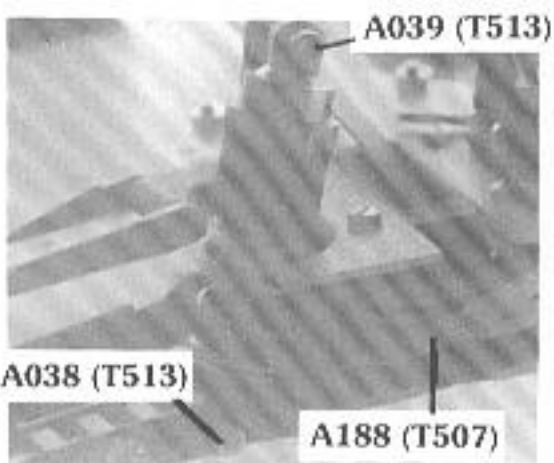

- 73 -

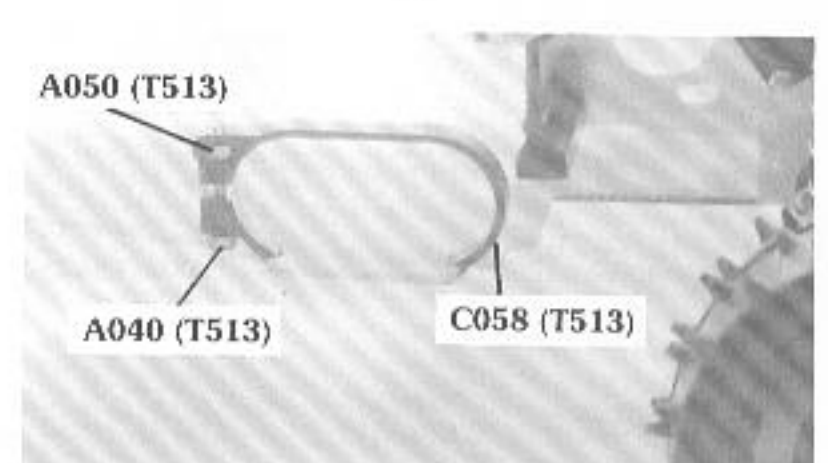

- 74 -

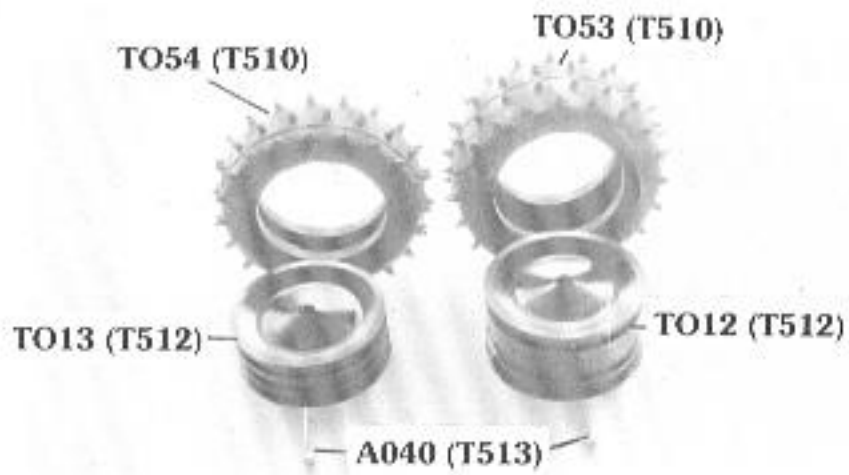

- 75 -

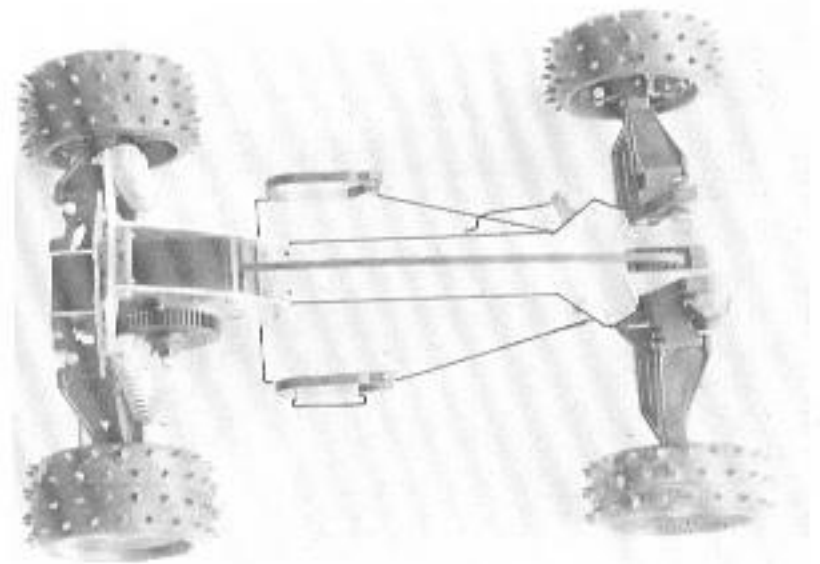

- 76 -

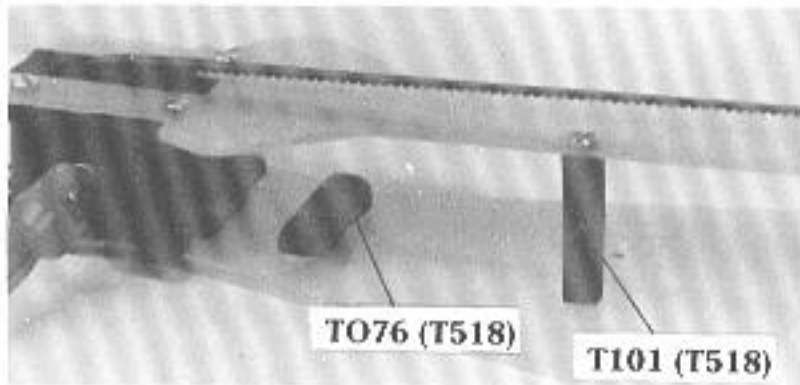

- 77 -

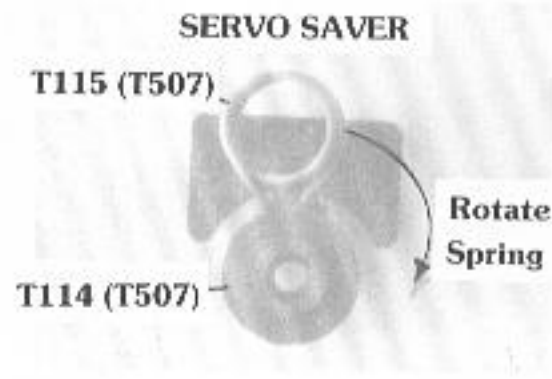

- 78 -



- 79 -

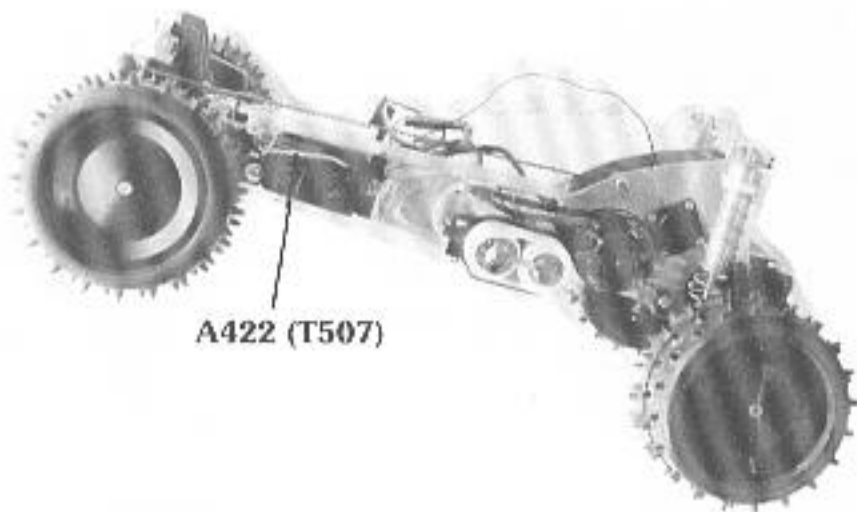

- 80 -

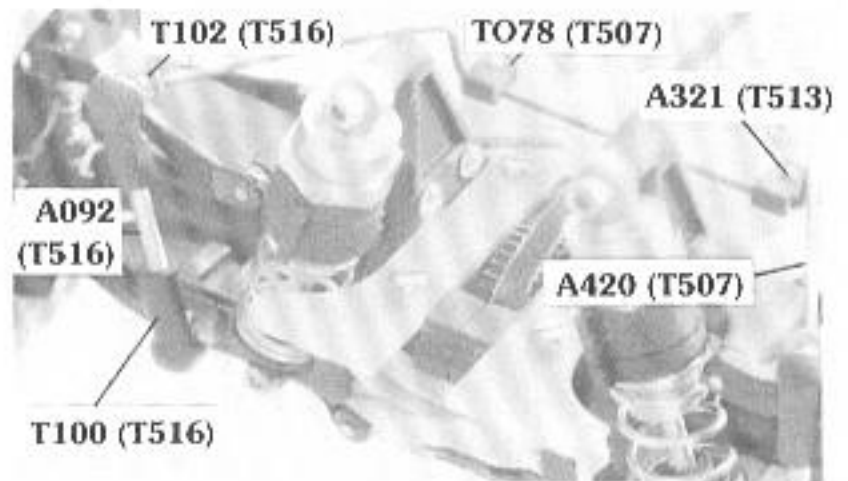

- 81 -

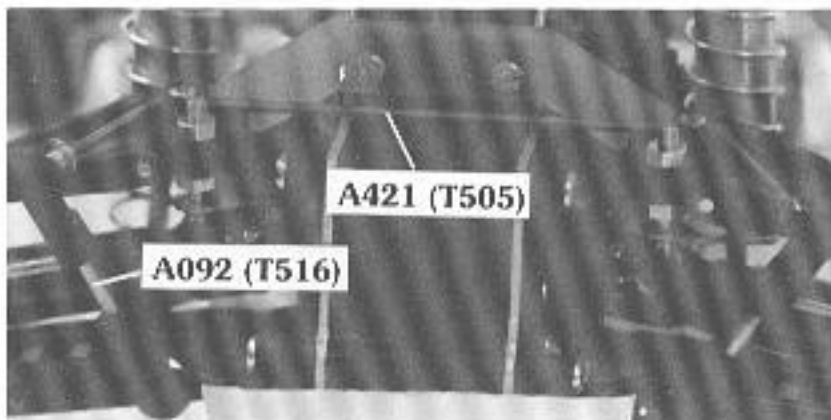

- 82 -

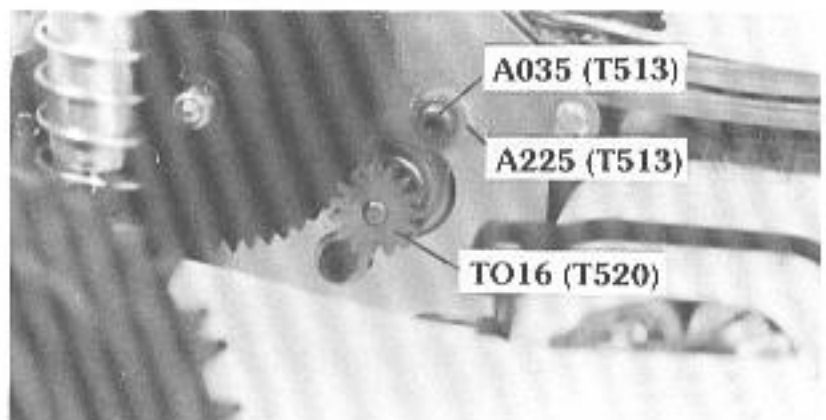

- 83 -

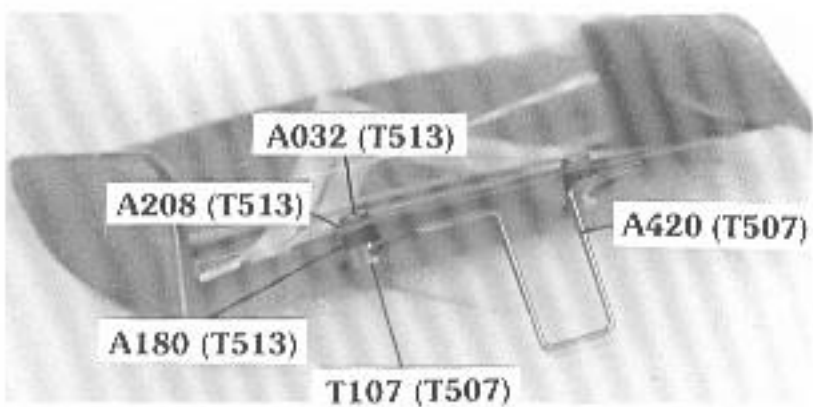

- 84 -



- 85 -

BAG NO	SPARES NO	PART NO	DESCRIPTION	NO OFF
		T400	CAT Non Electric Kit	1
T500/1			Rear Transmission Housing Assembly	1
T504/1			Chassis Parts	1
T505/1			Rear Suspension & Anti Roll Bars	1
T507/1			Front Suspension	1
T508/1			Body Moulding	1
T509/1			Undertray Moulding	1
T510/1			CAT Spiked Tyres	1
T511/1			Shock Absorbers	1
T512/1			Wheels	1
T513/1			Screw Bag Assembly	1
T514/1			Bearing Bag	1
T515/1			Drive Shaft Bag	1
T516/1			Joints Bag	1
T517/1			Bearing Housing Moulding	1
T518/1			Bracket Moulding	1
T519/1			Pulley Mouldings	1
T520/1			Transmission Assembly	1
T119			Aerial Tube	1
T521/1			CAT Box	1
T522/1			CAT Instructions	1
T500/1			Rear Transmission Housing Assembly	1
	T623	T623	Aluminium Side Plates	1
		T073	Motor Plate	1
		T072	Cover Plate	1
	T070	T070	Rear Transmission Housing - Inner	1
	T071	T071	Rear Transmission Housing - Outer	1
	T128	T128	Drive Belt 80/298/4 - Long	1
	T129	T129	Drive Belt 80/072/5 - Short	2
T504/1			Chassis Parts	1
	T074	T074	Chassis Plate - Lower	1
	T075	T075	Chassis Plate - Upper	1
	T103	T103	Front Bumper	1
T505/1			Rear Suspension	1
	T106	T106	Fibreglass Rear Shock Bracket	1
	T105	T105	Fibreglass Rear Suspension Bracket	1
	T624		Rear Suspension Pivots	1
		T079	Upper Rear Suspension Pivot	2
		A410	Stainless Steel Pin 2 x 26mm	2
		A412	Stainless Steel Pin 2 x 54mm	2
		T077	Lower Rear Suspension Pivot	4
	T104	T104	Hub Carrier - Rear	2
	T625		Rear Anti Roll Bar	1
		A421	Wire 2 x 135mm	1
		T078	Wire Clamp	2
	T616		Wishbone Set	1
		T109	Upper Wishbone 'A'	1
		T110	Upper Wishbone 'B'	1

BAG NO	SPARES NO	PART NO	DESCRIPTION	NO OFF
		T111	Lower Wishbone 'A'	1
		T112	Lower Wishbone 'B'	1
T507/1			Front Suspension	1
	T006	T006	Pivot Bracket - Front	2
	T058	T058	Arm - Front Suspension	2
	T626		Front Anti Roll Bar & Pins	1
		A410	Stainless Steel Pin 2 x 26mm	2
		A411	Stainless Steel Pin 2 x 40mm	4
		A420	Wire 1-6 x 180mm	2
		T107	Collar	2
		T078	Wire Clamp	2
	A188	A188	Tension Band	2
	T052	T052	Hub Carrier - Front	2
	T627		Servo Saver Assembly	1
		T114	Servo Saver Moulding	1
		T115	Servo Saver Spring	1
		A422	Wire Link - Servo Saver	1
	T616		Wishbone Set	1
		T109	Upper Wishbone 'A'	1
		T110	Upper Wishbone 'B'	1
		T111	Lower Wishbone 'A'	1
		T112	Lower Wishbone 'B'	1
		T116	Fibreglass Centre Trackrod	1
T508/1	T508	T508	Body Moulding (Includes Body, Belt Cover & Driver)	1
T509/1	T509	T509	Undertray Moulding (Includes Undertray, Wing, Motor Cover & Gear Cover)	1
T510/1	T510		CAT Spiked Tyres (Set of 4)	1
		T053	Rear Tyre 4 x 20	2
		T054	Front Tyre 3 x 20	2
T511/1	T511		Shock Absorbers	1
		T628	Front Shock Absorber Parts	1
		T117	Front Spring Stop Spacer	1
		T059	Cap - Shock Absorber	2
		T060	Body 16mm Stroke	2
		T062	Piston Rod 16mm Stroke	2
		T091	Rod End - Short	2
		T064	Brass Bush	2
	T629		Rear Shock Absorber Parts	1
		T059	Cap - Shock Absorber	2
		T061	Body - 32mm Stroke	2
		T063	Piston Rod - 32mm stroke	2
		T064	Brass Bush	2
		T113	Rod End - Long	2
	T614		Shock Absorber Seals	1
		A230	Stepped Washer 1/8	4
		A208	Nylon Washer M3 x 0.8	8

BAG NO	SPARES NO	PART NO	DESCRIPTION	NO OFF
		A206	Nylon Washer 3.3 x 8.0 x 1.6	8
		A190	"O" Ring ID 9mm x 1.6	4
		A103	"E" Clip 1/8 x .012"	8
		A170	"U" Seal 1/8 x 5/16	4
		A181	Silicone "O" Ring 1/8	4
		A209	Black Washer 3.3 x 7.8 x 0.8mm	4
		A120	Circlip 8mm x 0.8	4
		T096	Piston 1sq mm Hole (Front)	2
		T097	Piston 2sq mm Hole (Rear)	2
	T613		Spring Stops & Spacers Moulding	1
		T090	Spring Stop	4
		T092	Spring Spacer 1-0	4
		T093	Spring Spacer 2-0	4
		T094	Spring Spacer 4-0	4
		T095	Spring Spacer 8-0	4
	T127	T127	Suspension Spring .055 x 4 (Front)	2
	T126	T126	Suspension Spring .045 x 11 (Rear)	2
	T512/1		Wheels (Set of 4)	1
		T012	Rear Wheel	2
		T013	Front Wheel	2
	T513/1		Screw Bag Assembly	1
		T620	Screw Bag "A" - Self Taps	1
		A301	Self Tap No.2 x 3/16" Pan Hd	16
		A304	Self Tap No.2 x 3/8" Pan Hd	12
		A321	Self Tap No.4 x 1/4" Pan Hd	2
		A323	Self Tap No.4 x 3/8" Pan Hd	36
		A324	Self Tap No.4 x 1/2" Pan Hd	6
		A325	Self Tap No.4 x 5/8" Pan Hd	4
		A326	Self Tap No.4 x 3/4" Pan Hd	6
		A336	Self Tap No.4 x 3/4" Csk Hd	4
	T621		Screw Bag "B" M3 & M4	1
		A050	Alluminium Nut M3	16
		A051	Nut M3 Nyloc	8
		A012	Alluminium Screw M3 x 8 Ch Hd	6
		A013	Alluminium Screw M3 x 10 Ch Hd	8
		A015	Alluminium Screw M3 x 16 Ch Hd	4
		A052	Alluminium Screw M4 x 8 Csk Hd	2
		A039	Stainless Steel Screw M3 x 16 Cap Hd	4
		A040	Stainless Steel Screw M3 x 20 Cap Hd	6
		A032	Stainless Steel Screw M3 x 6 Pan Hd	2
		A035	Stainless Steel Screw M3 x 6 Cap Hd (Motor Screw)	2
		A225	M3 Steel Washer (For Motor Screws)	2
		A038	Stainless Steel Screw M3 x 12 Cap Hd	4
	T622		Screw Bag "C" Assorted	1
		A208	Nylon Washer M3 x 0.8	6
		A154	Disk Spring 1/8"	3
		A141	Socket Wrench 1.5mm A/F	1

BAG NO	SPARES NO	PART NO	DESCRIPTION	NO OFF
		A143	Socket Wrench 2.5mm A/F	1
		A214	Nylon Spacer	4
		C058	Nicad Clamp	2
		A180	"O" Ring 1/8"	8
		T121	Sticky Pad 1" x 1/2"	4
		T122	Velcro 50 x 20mm	1
		A206	Nylon Washer 3.3 x 8.0 x 1.6	2
			Stickers (2 Blue - 2 Black)	
	T514/1	T514	Bearing Bag	1
		A510	A510 Ball Race 1/8 x 1/4 NF	2
		A530	A530 Ball Race 8 x 16 x 5 NF	14
		A541	A541 One-way Clutch 6 x 10 x 12	2
	T515/1		Drive Shaft Bag	1
		T612	Hub Moulding	1
		T031	Rear Hub	2
		T029	Front Hub	2
		T030	Wheel Hub	4
	T630		Drive Shafts	1
		T027	Drive Shaft - Inner	4
		T028	Drive Shaft - Outer	4
	T631		Universal Joint Bag	1
		T108	Universal Joint Pivot Assembly	8
		T131	Universal Joint Assembly Tool	1
	T516/1	T516	Joints Bag	1
		T045	Pivot Ball	20
		T102	Rod End Ball	4
		A092	Stud M3 x 24	6
		A091	Stud M3 x 12	4
		A095	Stud M3 x 45	2
		T100	Ball Socket	16
		A093	Stud M3 x 35	2
	T517/1	T517	Bearing Housing Moulding	1
		T082	Diff Bearing Housing - Open	1
		T083	Diff Bearing Housing - Closed	1
		T081	Rear Bearing Housing - Eccentric	2
		T087	Thrust Washer Carrier - Inner (Drive Teeth)	1
		T088	Thrust Washer Carrier - Outer (Plain)	1
		T098	Steering Lever	2
		T099	Radius Arm	2
	T518/1	T518	Bracket Moulding	1
		T056	Bracket "A" Front Suspension	2
		T057	Bracket "B" Front Suspension	2
		T076	Mounting Bracket	4
		T101	Servo Mount	2

TRACK SETTINGS

In general the car should understeer - this means the front wheels slide more than the rear wheels during cornering. You can get this by cutting the spikes of the front tyres down. It helps to have two or three sets of front tyres with different levels of spikes to test for the best option.

Run the lowest ride height that track conditions will allow - a low car always corners better than a high car.

Use the softest damper settings that stop the wheels from bouncing. It is very easy to over damp the car and cause bouncing at speed.

Your 'CAT' is a thoroughbred racer and therefore has various adjustments to enable you to get optimum performance over a wide range of track conditions.

The following chart lists these features and the columns show examples of settings for particular conditions. Column (1) will provide safe, predictable handling for general testing and demonstrating. Other columns illustrate race winning specifications for the circuits shown.

It is an enormous help to return to a circuit with the car well set up right from the first lap.

1	Circuit Type	Standard Test Spec	Worlds End Mainly grass Very bumpy	Chesham Long Track Fast, grassy Tarmac bends	Southend Wide Ranging Conditions
2	Rear anti roll bar dia Std 01.8	Std	Std	Std	Std
3	Rear anti lower fixing	2nd hole out	3rd hole out	3rd hole out	3rd hole out
4	Rear damp lower fixing	3rd hole out	3rd hole out	3rd hole out	2nd hole out
5	Rear damp Oil type	10 W 40	EP90	10 W 40	10 W 40
6	Rear damp Piston	Std	Doubled orifice	Std	Std
7	Rear damp spacers under piston	Nil	Nil	Nil	Nil
8	Rear damp spring	Std	Std	T133 .045 x 11 x 2.5	T133 .045 x 11 x 2.5
9	Rear damp spring spacers	Nil	Nil	4mm	10mm
10	Rear Lower wishbone offset	Rearward	Forward	Forward	Forward
11	Rear bump steer	Nil	Nil	Nil	Nil
12	Rear toe in	Nil	Nil	Nil	Nil
13	Front anti roll bar dia Std 01.6	Std	Std	Std	Std
14	Front anti lower fixing	3rd hole out	3rd hole out	4th hole out	4th hole out
15	Front Damper lower fixing	1st hole out	1st hole out	1st hole out	1st hole out
16	Front Damper Oil type	10 W 40	EP90	10 W 40	10 W 40
17	Front Damper Piston	Std	Doubled orifice	Std	Std
18	Front Damper Spacers under piston	4mm	4mm	Nil	Nil
19	Front Damper Spring	Std	T132 .045 x 8 x 1.5	T132 .045 x 8 x 1.5	T132 .045 x 8 x 1.5
20	Front Damper Spring spacers		4mm	4mm	4mm
21	Front lower wishbone offset	Forward	Forward	Forward	Forward
22	Front bump Steer	Nil	Nil	Nil	Nil
23	Front toe in	Nil	Nil	Nil	Nil
24	Front Tyres Std - Natural Rubber N63	Schumacher spikes cut to half height	Std Schumacher spikes	Schumacher spikes outer row removed	Schumacher spikes outer row removed
25	Rear Tyres	Std Schumacher spikes	Std Schumacher spikes	Std Schumacher spikes	Schumacher Synthetic Spikes S70 Part No. T 525
26	Front Drive Integrator No Drive - 0% Full Drive - 100%	50%	50%	50%	100%
27	Motor Type	27 T Std	18 T Std	18 T Std	18 Std
28	Gear Ratio	16/58	13/58	15/60	14/60
29	Batteries	Sanyo SCR	Schumacher Custom Pack SCR	Schumacher Custom Pack SCR	Schumacher Custom Pack SCR
30	Total running time	6 min	5½ min		7 min
31	No of laps	-	16	17	15
32	Race duration	5 min	5 min	5 min	5 min
33	Weather conditions	Fine & dry	Fine & dry	Fine & dry	Fine & dry
34	Date	21.9.86	21.9.86	28.9.86	5.10.86
35	Result	-	1st & TQ	1st & TQ	1st & TQ
36	Other				Wing Back 25mm
37					
38					

Manufactured and distributed by:
Schumacher Racing Products
'Rudge', Harlestone Road
Church Brampton
Northampton NN6 8AU

Please note the following amendments to your instructions:

STUDS

Early kits contain the following studs:

A092	Stud M3 x 30	6 off (cut down to 24mm if necessary)
A091	Stud M3 x 12	4 off (no change)
A095	Stud M3 x 40	4 off (use 2 off instead of A093 for rear track rods)

Part numbers on photographs remain correct.

BUMPERS

To strengthen the bumper, smooth and radius the edges and remove the machining marks.

FRONT SUSPENSION ARMS

To allow the front shock absorber mounting position to be adjusted, the T058 front suspension arms and front upper wishbones, may be assembled on the opposite side of the car. ie Instead of curling around the front shock absorbers for protection as shown in photograph 73, they point towards the rear of the car.

GEAR RATIOS

The following gear ratios may be added to the gear ratio chart.

GEAR	PINION	OVERALL RATIO	MM/REV
60	10	14.57	18.87
58	12	11.74	23.55
55	15	8.90	31.05

PRINTING ERRORS

Photo 70 Part T133 should read T113

Photo 72 Part A051 should read A038

Page 15 T116 should be written in spares No column as well as part No column