

# CAT<sup>SVII</sup>

Competition - All - Terrain

## Instruction Manual v1.0



CompetitionX  
A WEB SITE FOR SERIOUS RACERS

Schumacher Racing  
73 Tenter Road  
Moulton Park  
Northampton  
NN3 6AX  
U.K  
[WWW.racing-cars.com](http://WWW.racing-cars.com)

## Additional Items Required

Transmitter and Receiver  
(including batteries for tx)

CR38  
CODE 2.4G 2 Stick 3Ch Tx+Rx  
CR39  
CODE 2.4G 2 Stick 3Ch Receiver ONLY



Servo

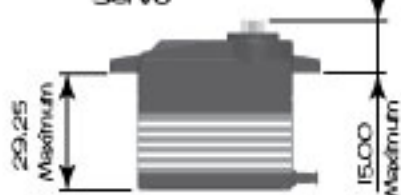

Electronic Speed Control



Li-Po Battery

Maximum 24.00mm High



Motor



Pinion Gear

Battery Charger



Paint



Shock Oil SuperGlue

## Tires and Inserts



Tools



5.5 A/F Combination Wrench



Long nose Pliers



HiVIO Wiha Precision  
Circlip Pliers



CR044 Curved Body Scissors



U2789 Hex Driver - 1.5mm  
U2790 Hex Driver - 2.0mm  
U2791 Hex Driver - 2.5mm



U2795 M3 Nut Driver  
U2796 M4 Nut Driver



ED190009 Tumbuckle Wrench 4mm



Soldering Iron

U3107 - Solder

# CAT

COMPLETION - ALL - TERRAIN

Schumacher Racing stocks and distributes the following manufacturers products and full product listings are available on our website at [www.racing-cars.com](http://www.racing-cars.com).

PLEASE NOTE THAT SOME OF THE PRODUCT RANGES BELOW ARE ONLY AVAILABLE IN THE UNITED KINGDOM.

CORE-RC

NISRAM

Speed Assion  
RC Technology Revolution

GM

Wiha

East Coast  
Bodies Tune

TEAM  
SOREX

EDS  
Specialized RC Tools

TRIX  
TOOLS  
Products are not sold in the UK

## IMPORTANT SAFETY NOTES

- This product is not suitable for children under the age of 14, without the direct supervision of an adult.
- Select an area for assembly that is away from the reach of small children. The parts in this kit are small and can be swallowed by children causing choking and possible internal injuries.
- Exercise care when using hand tools and sharp instruments during assembly.
- Carefully read all manufacturers warnings and cautions for any additional parts used in the construction.
- In line with our policy of continuous development the exact details of the kit may vary.

Step I A

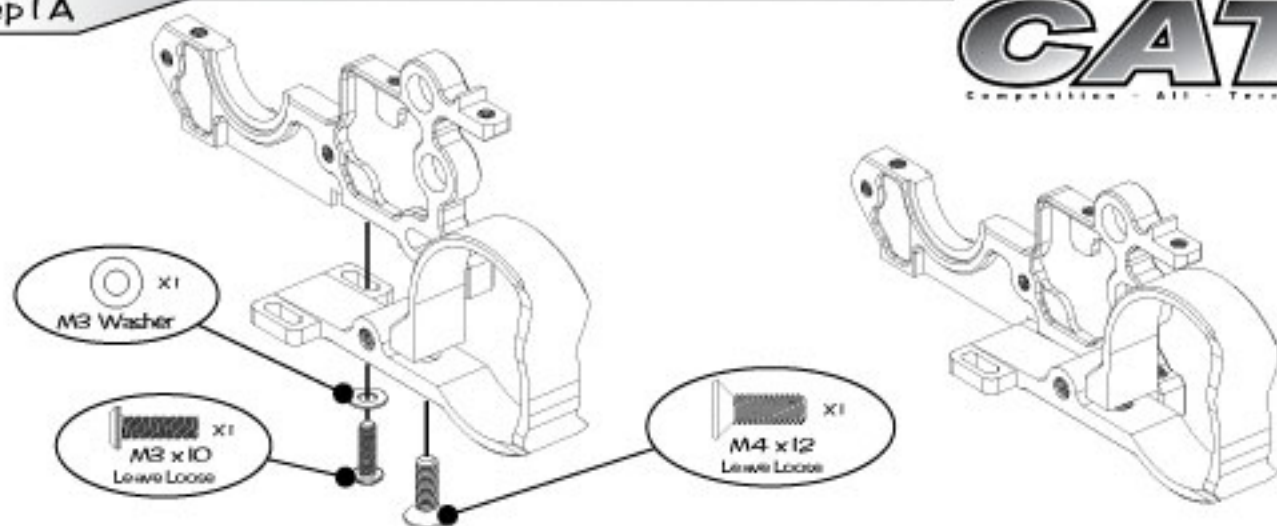

Step I B

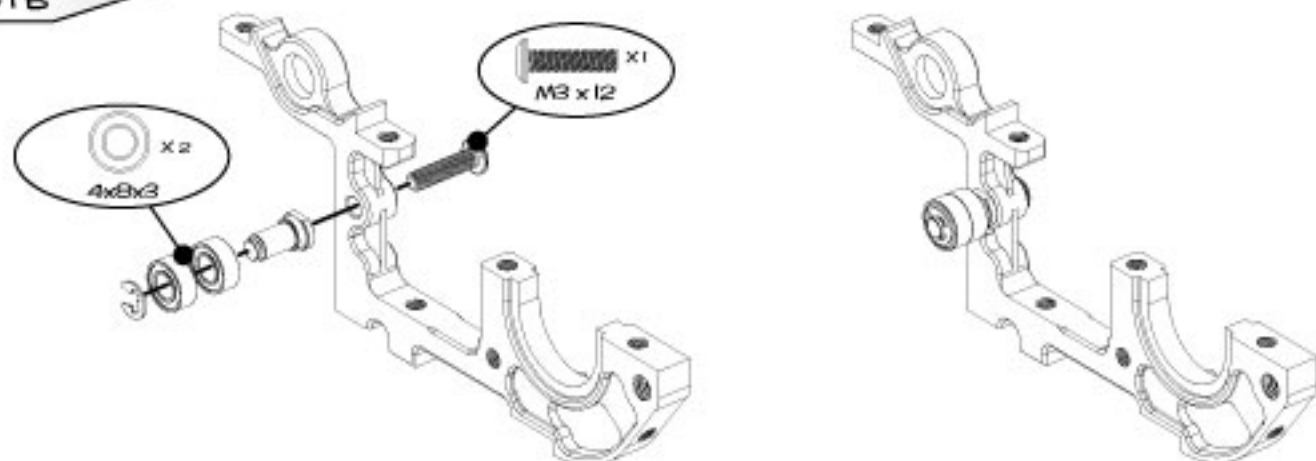

Step I C

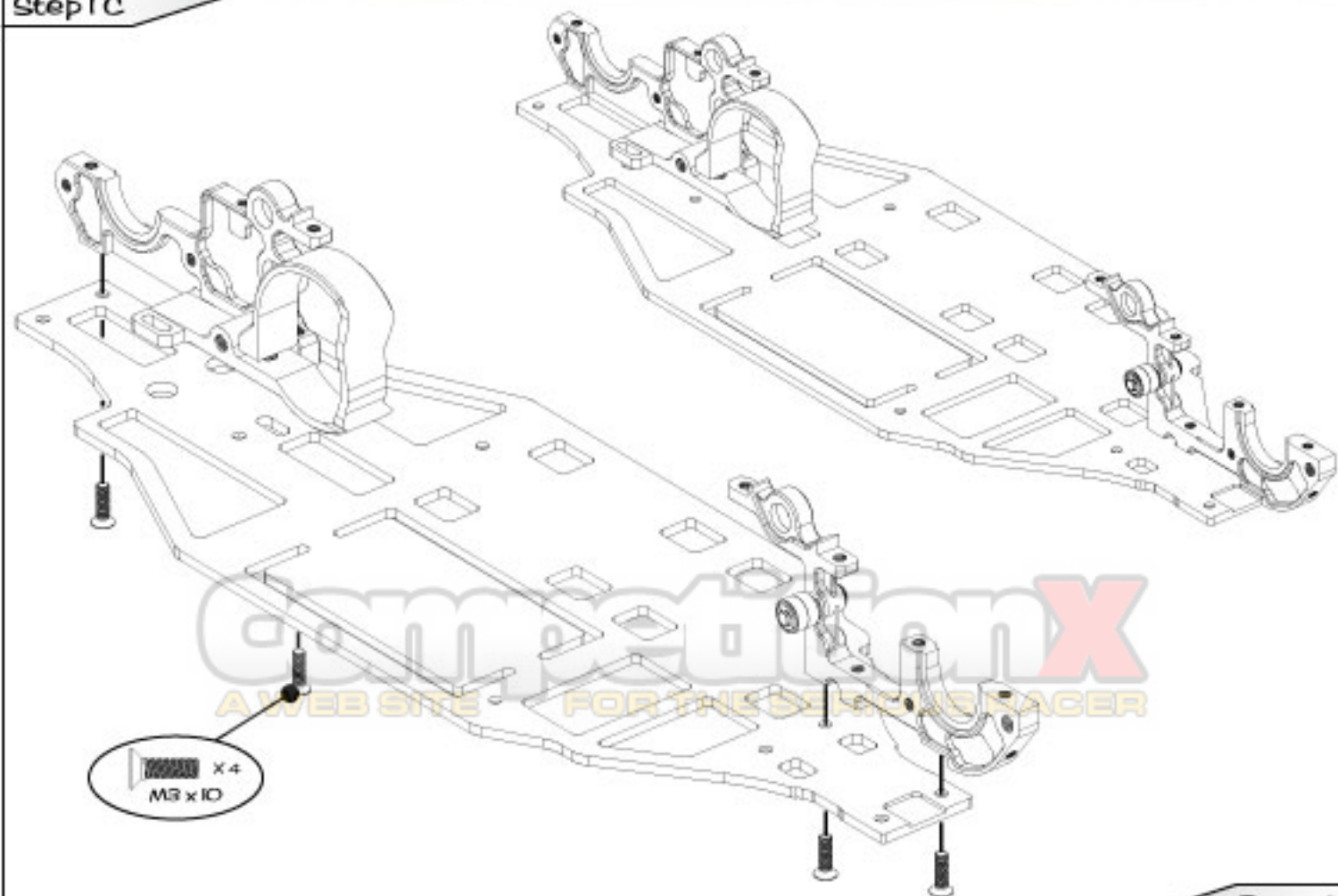



Step 2 A

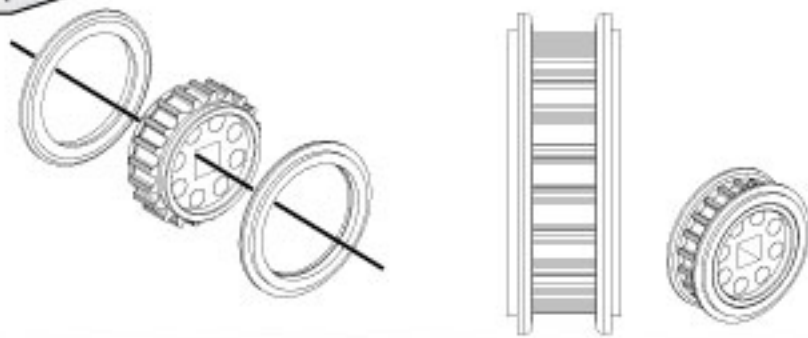

Step 2 B

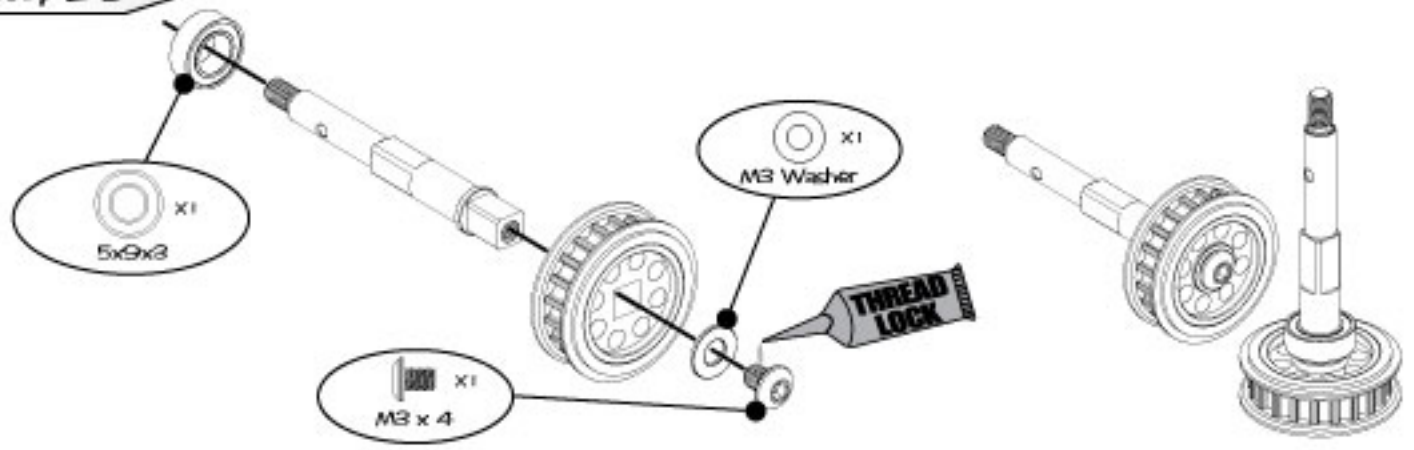

Step 2 C

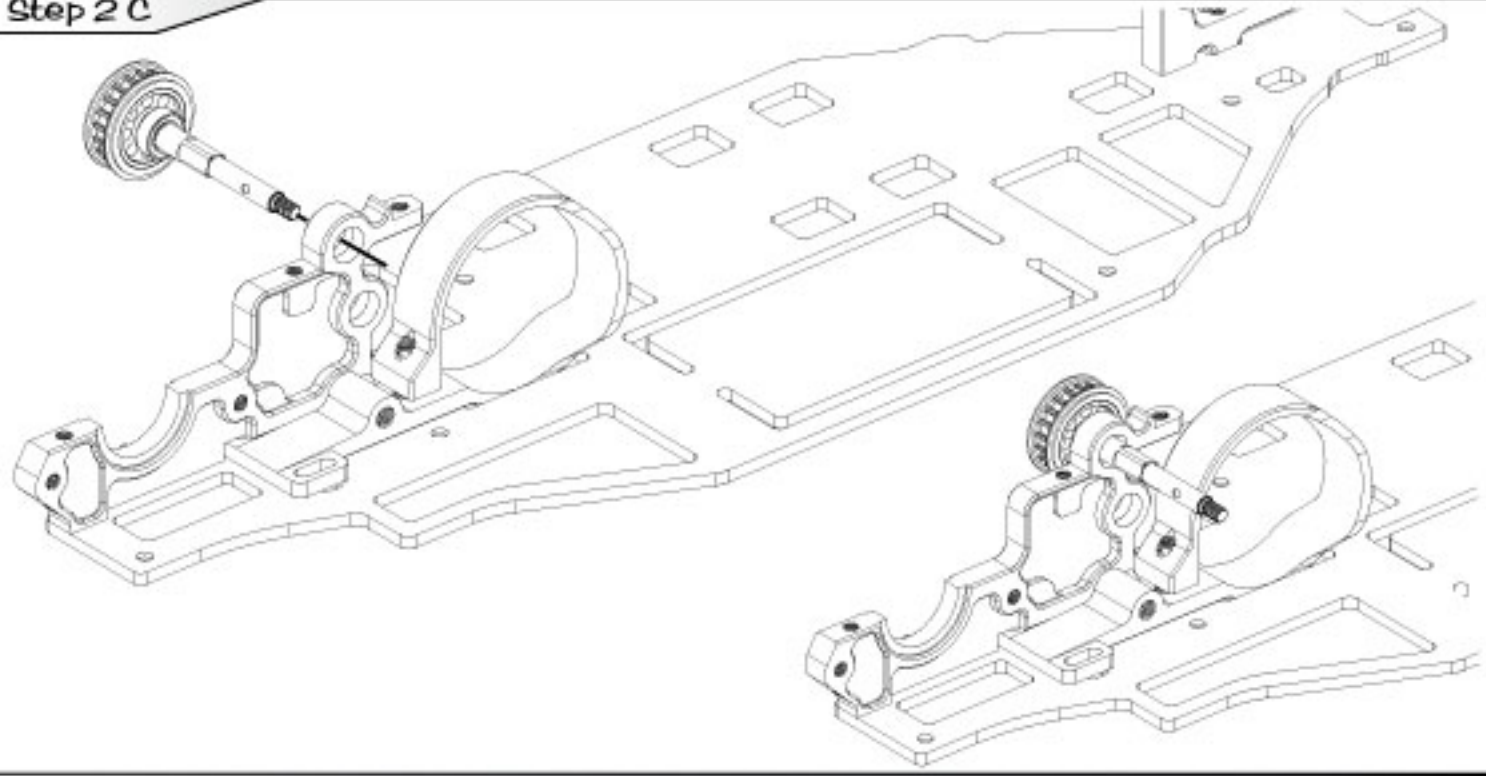

Step 3 A

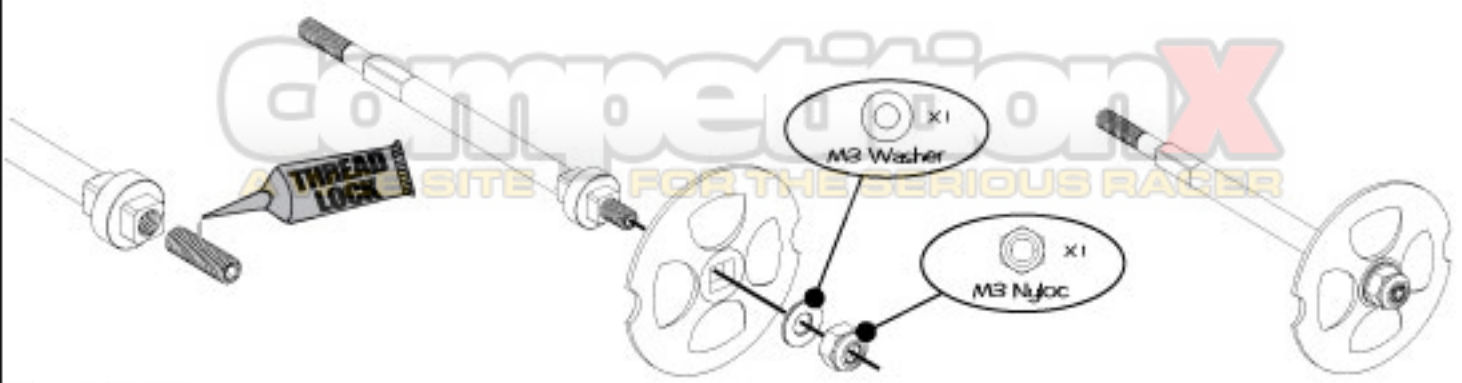



### Step 3 B

Ensure the Slipper disks are located correctly in the spur gear

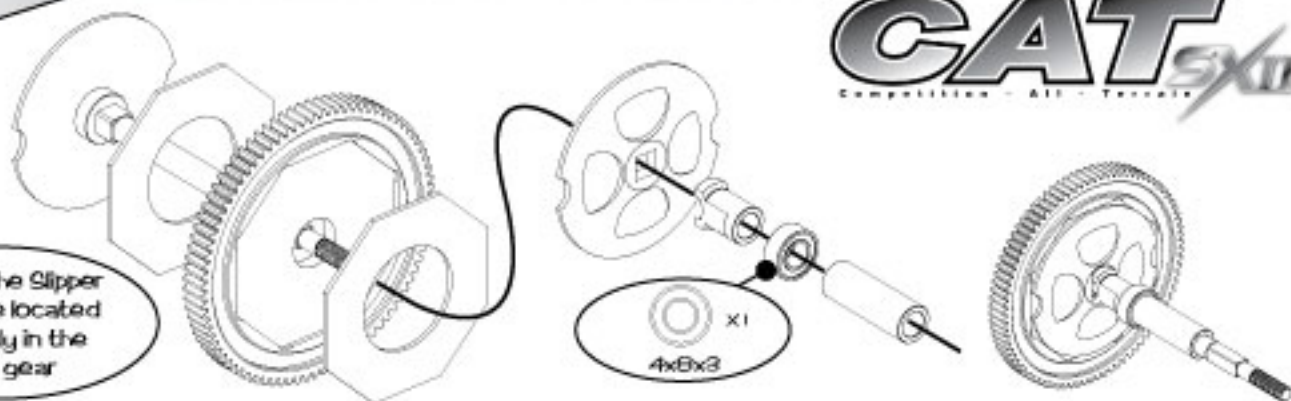

### Step 3 C

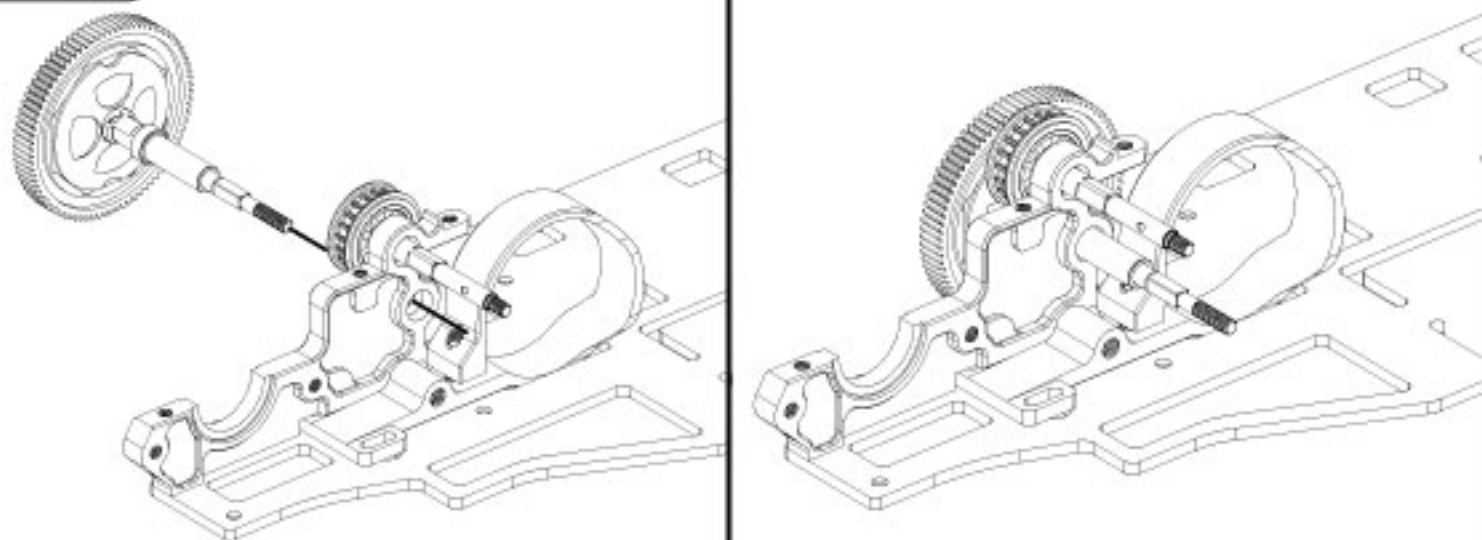

### Step 4 A



### Step 4 B

Ensure the Belt is assembled between the two shafts

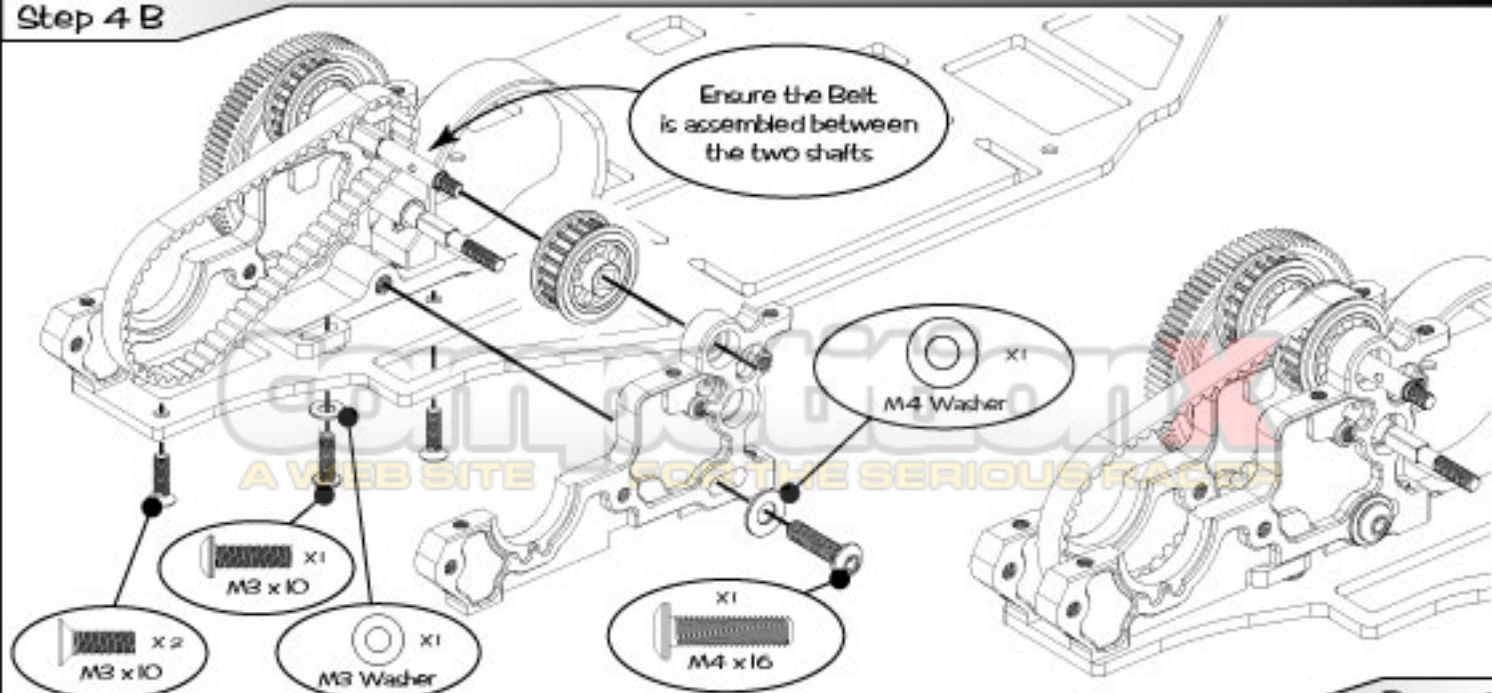

### Step 5

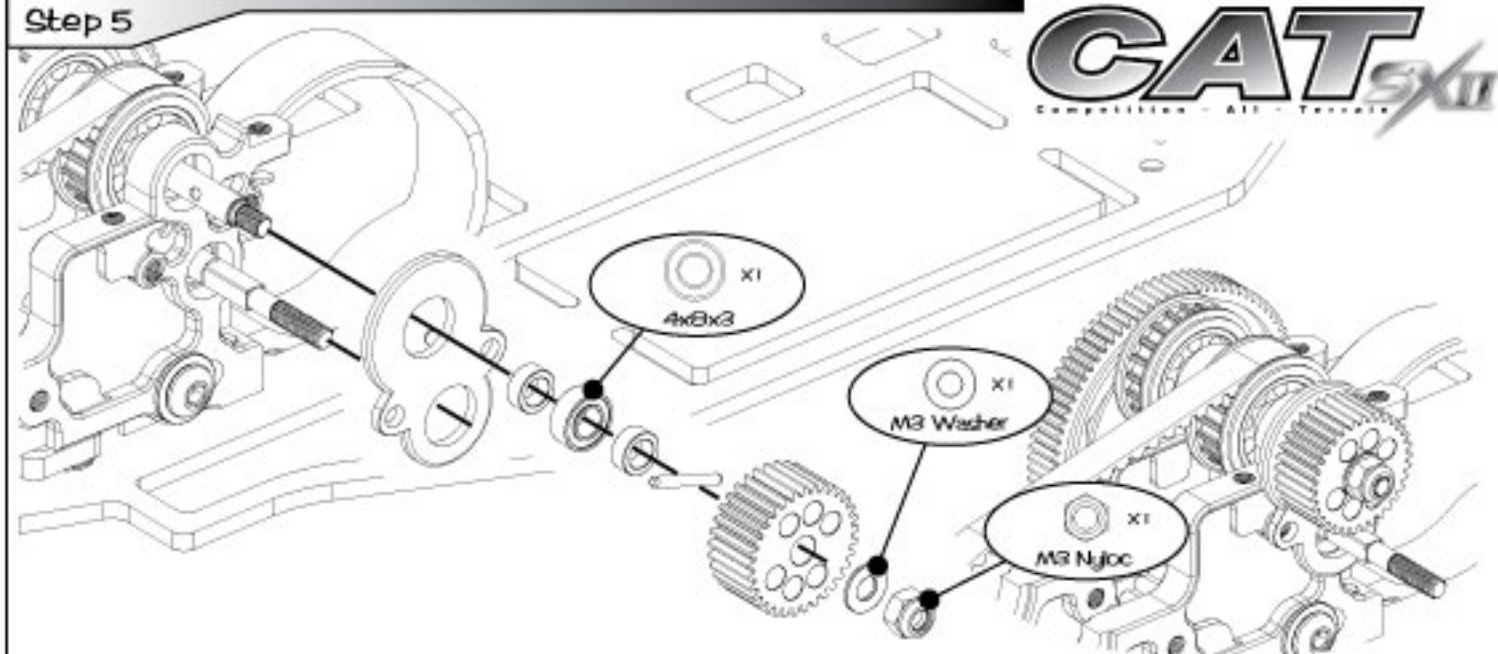

### Step 6

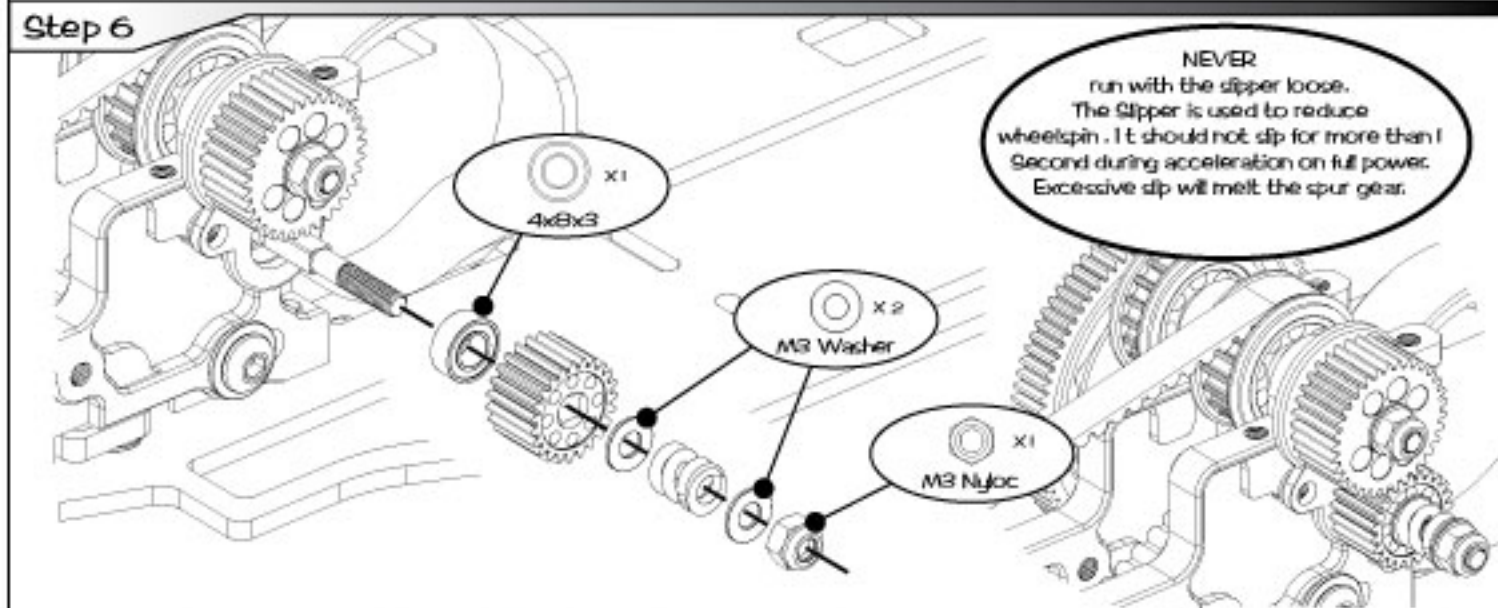

### Step 7 A



### Step 7 B

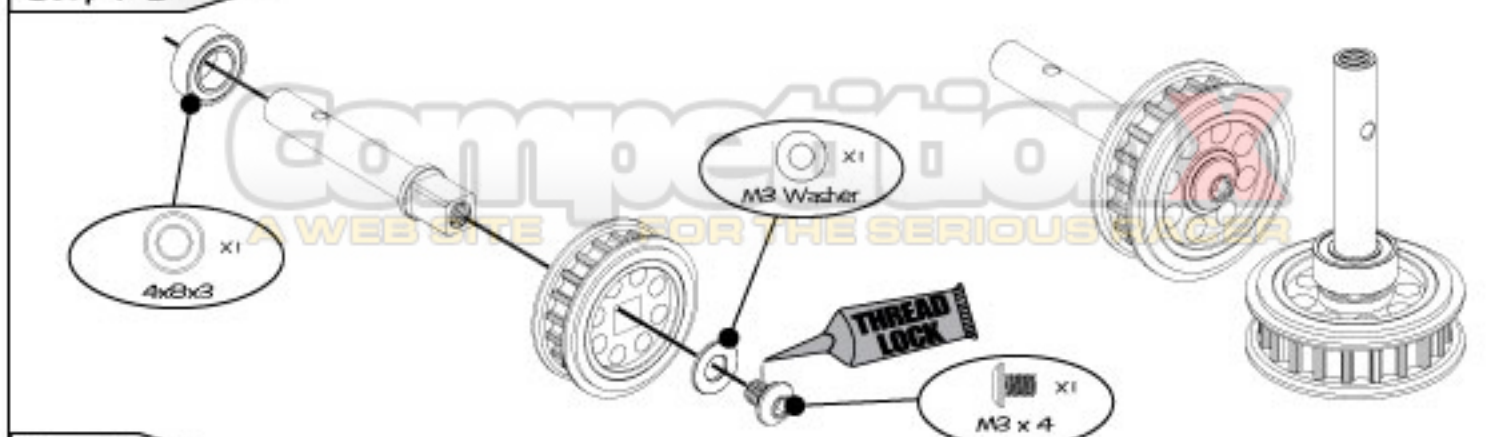



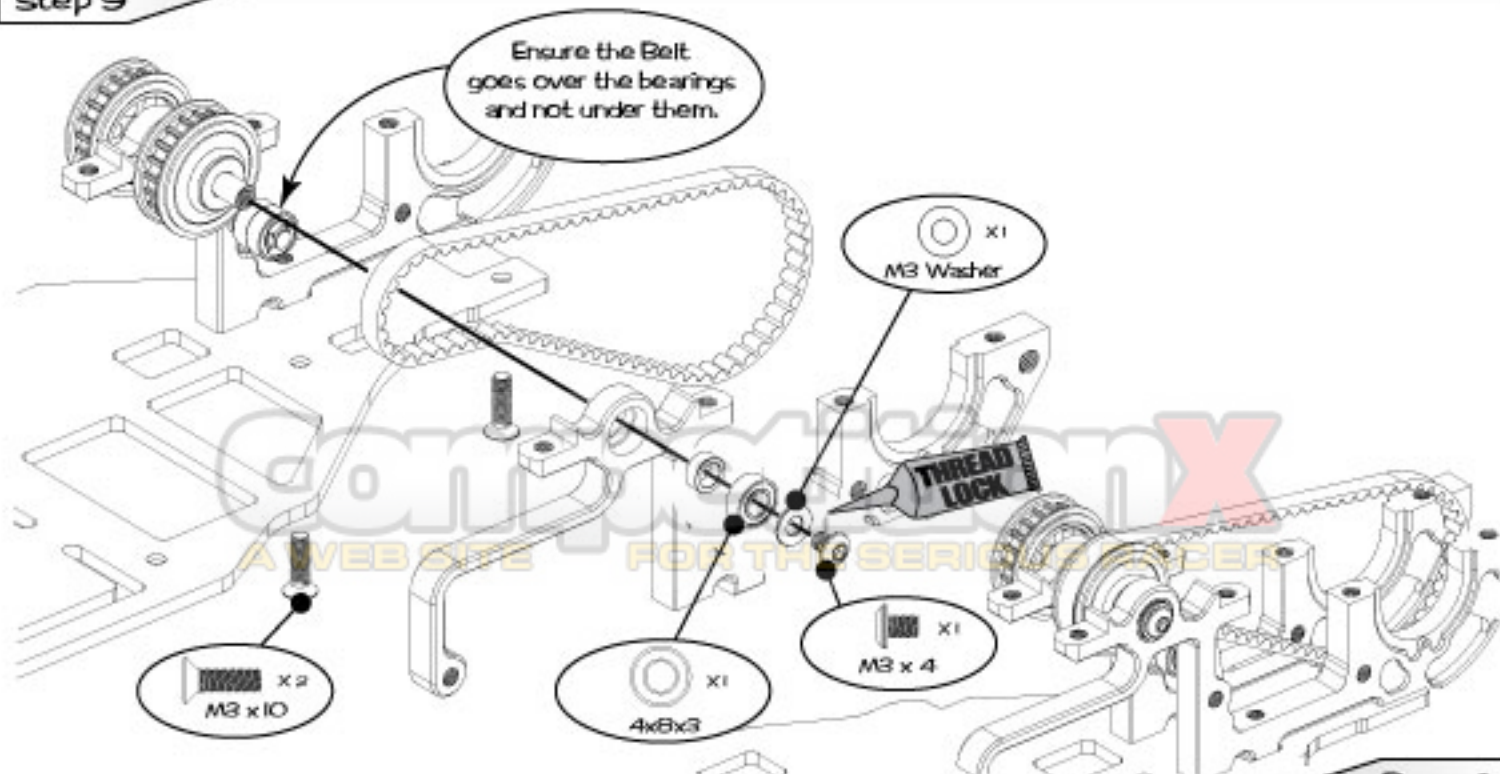
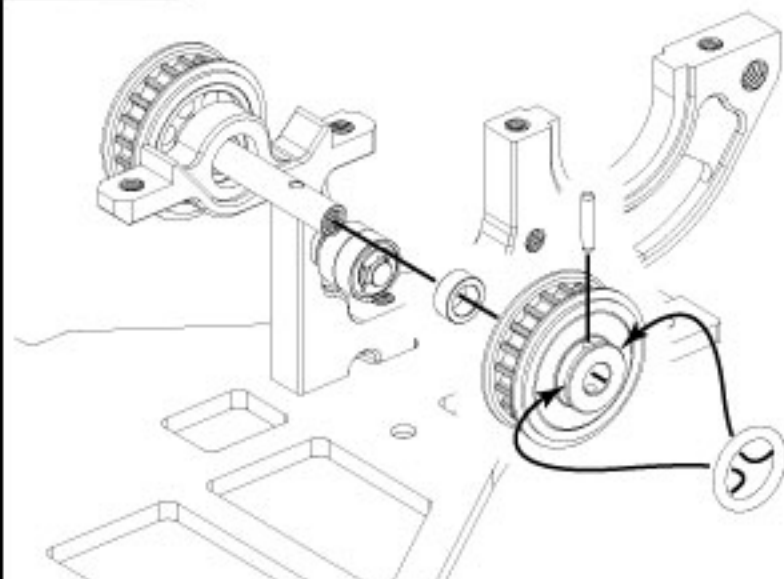
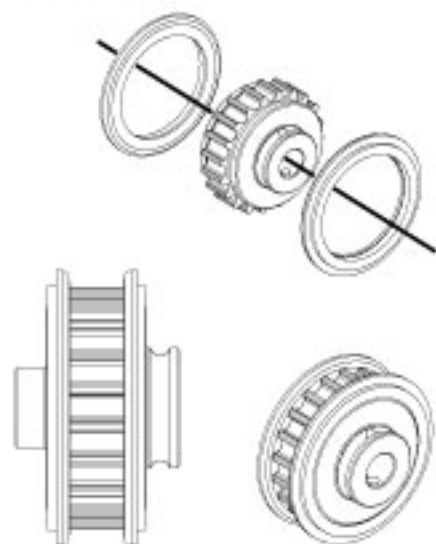
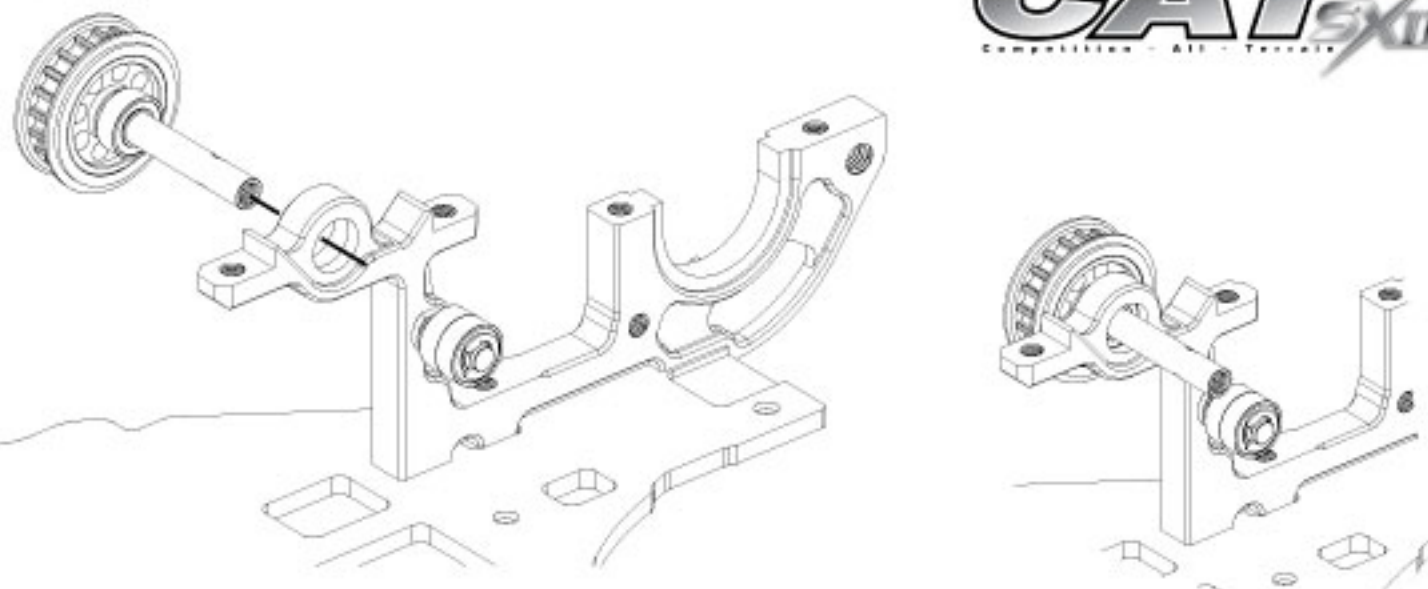



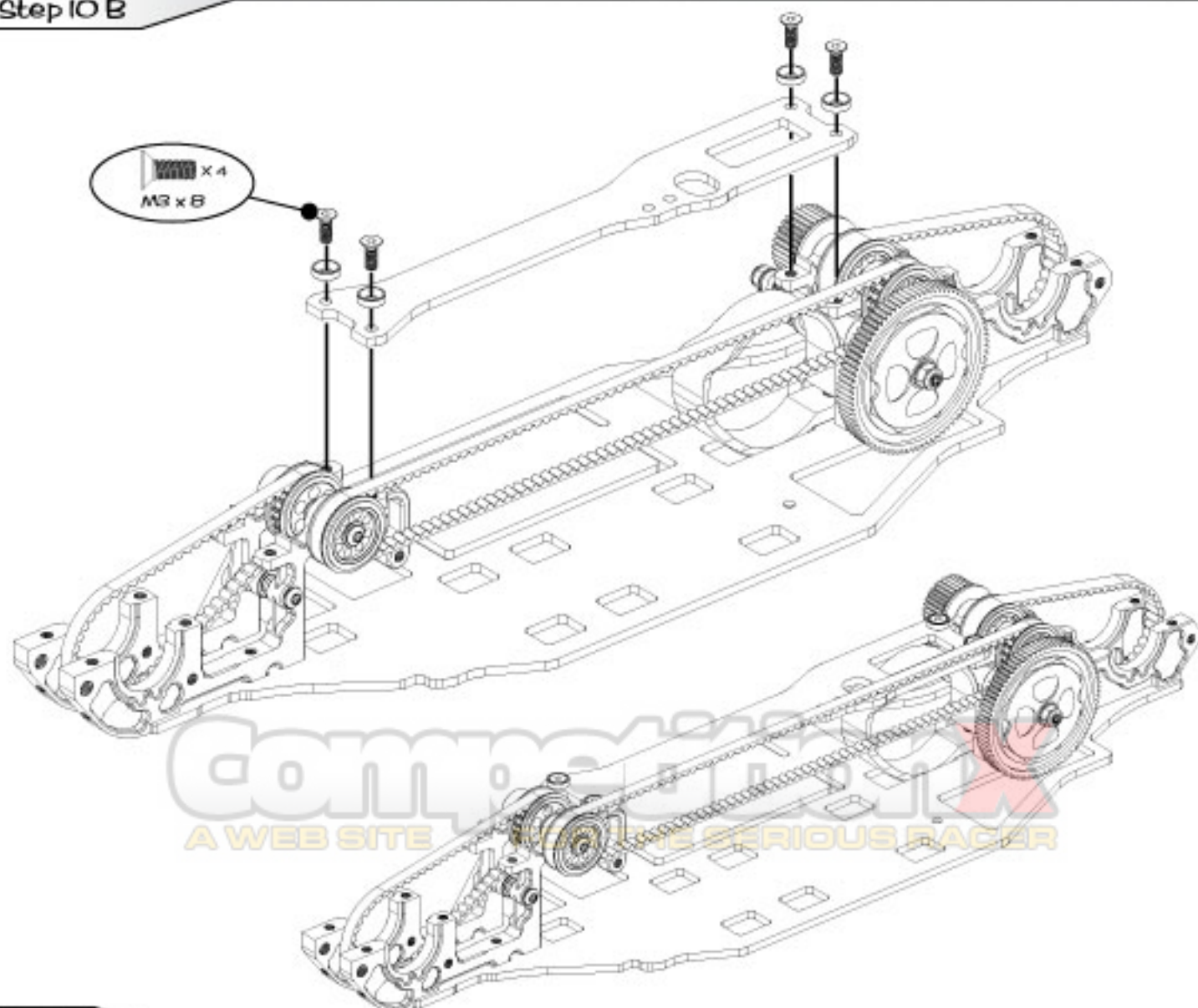
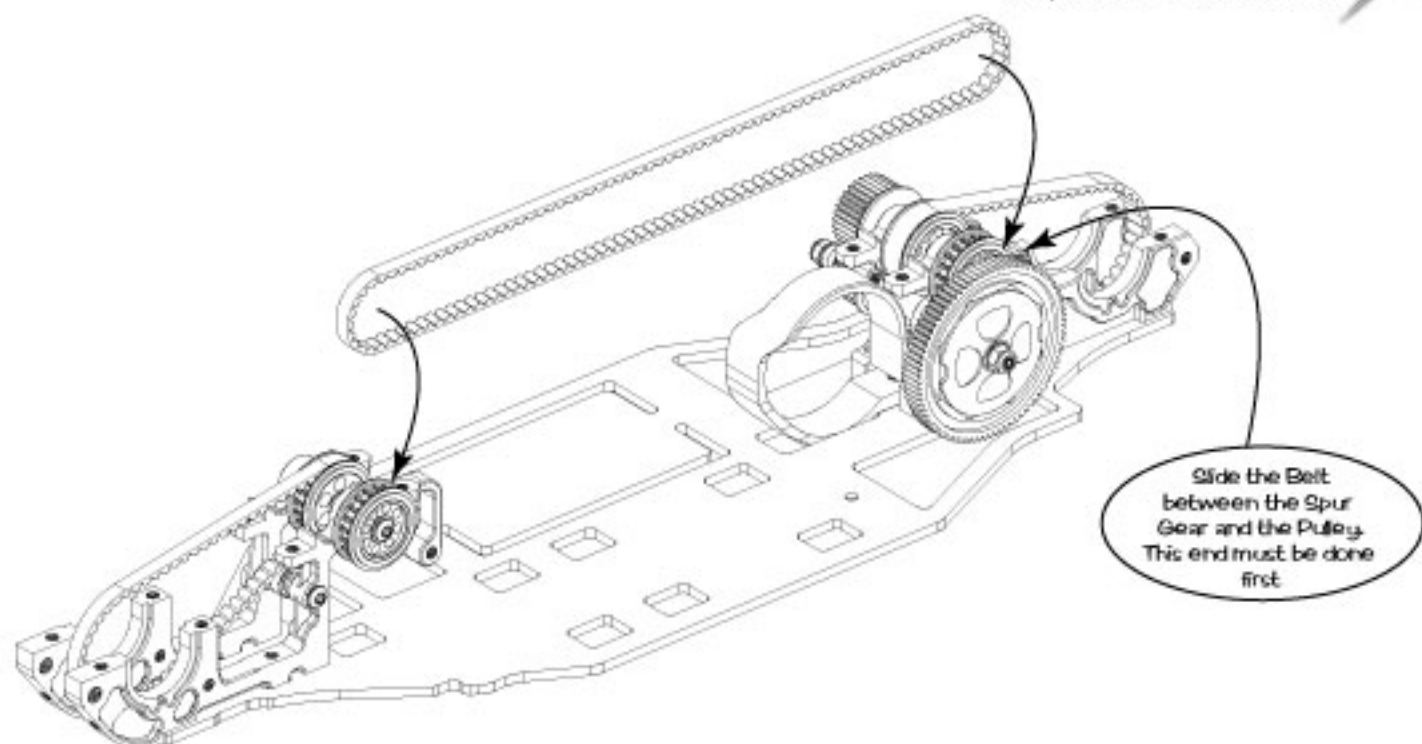

Step 11 A

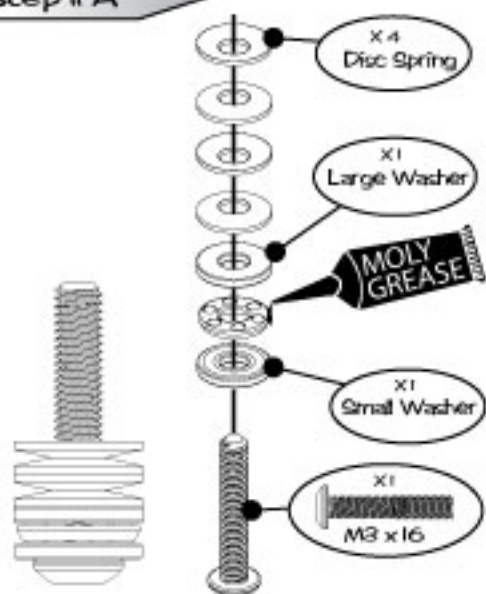

Step 11 B

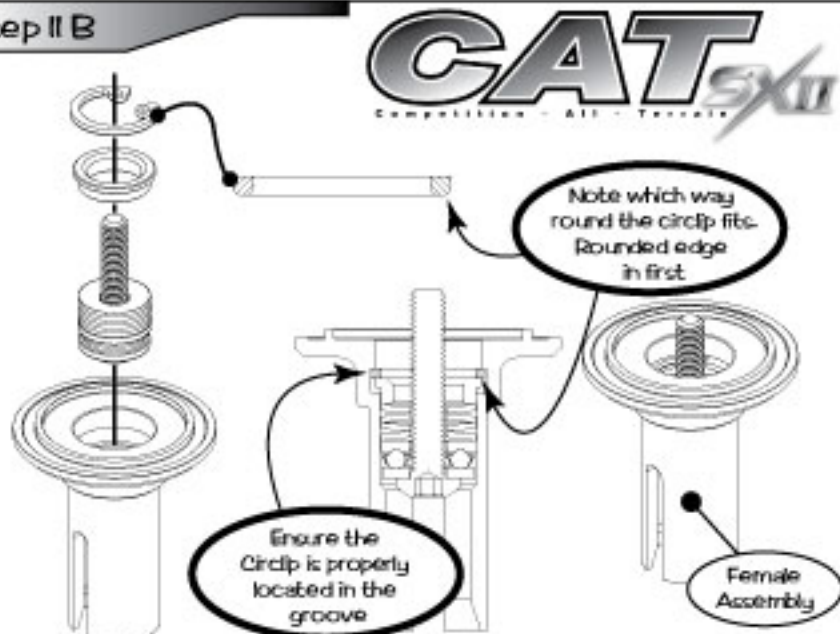

Step 12 A

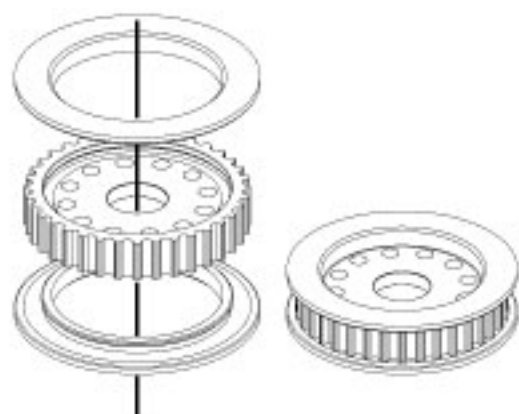

Step 12 B

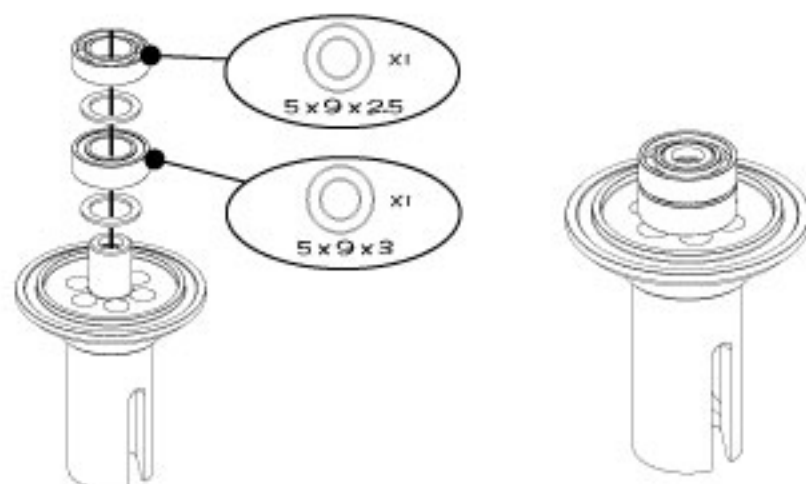

Step 13 A

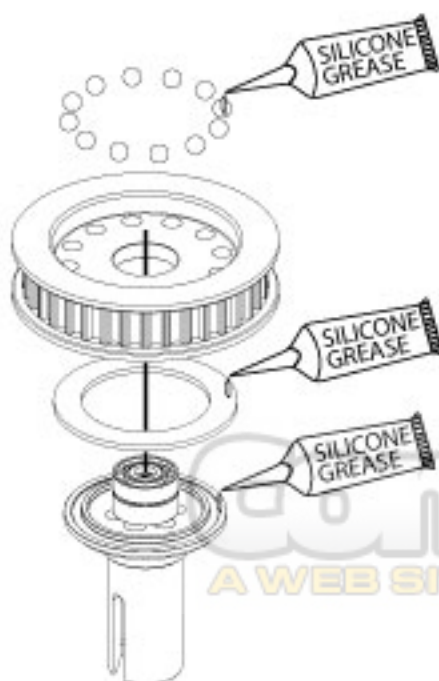

Step 13 B

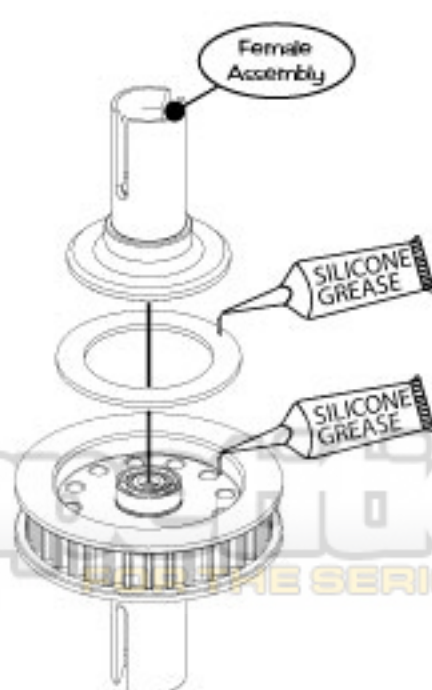

Step 13 C

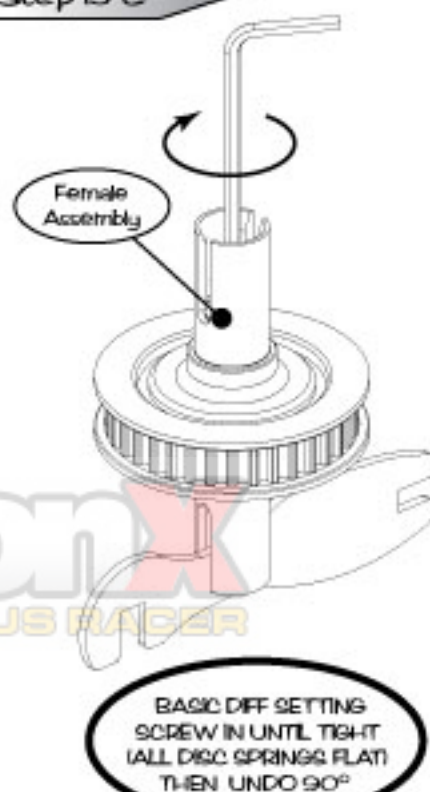

A WEB SITE FOR THE SERIOUS RACER



### Step 13 D

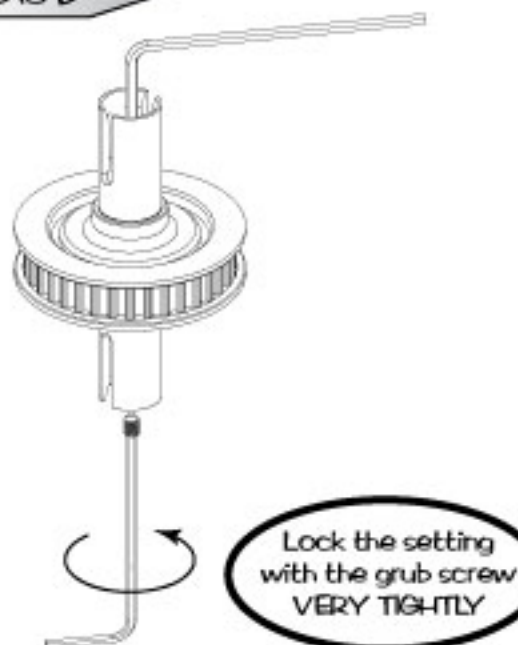

### Step 13 E

**CAT**  
Competition - All - Terrain

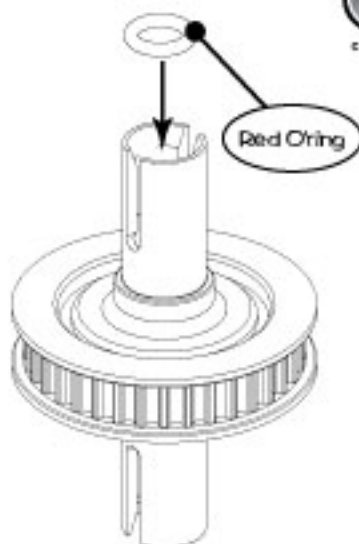

Now Repeat steps 11, 12 and 13 to build 2, identical Diffs

### Step 14 A

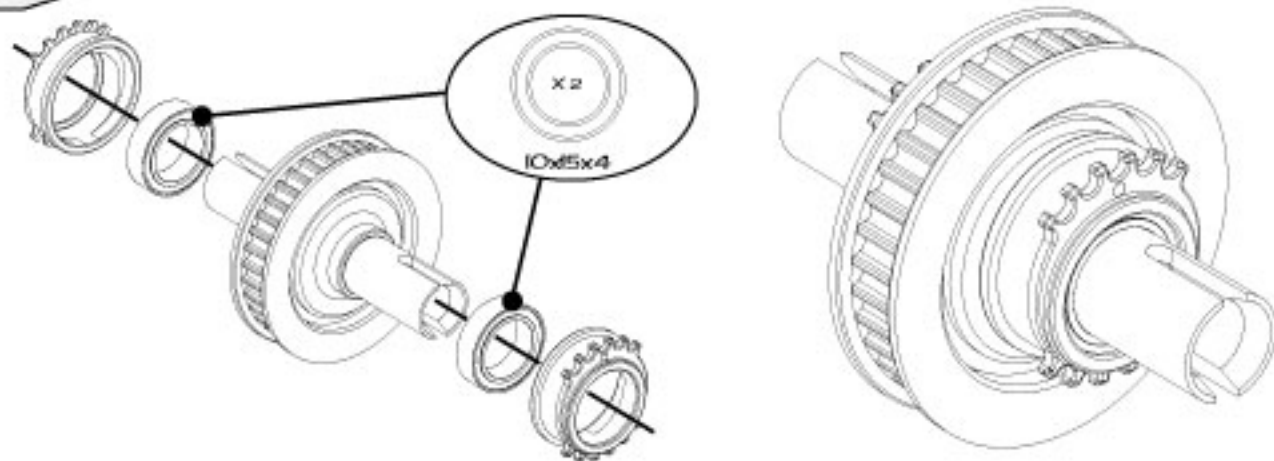

### Step 14 B

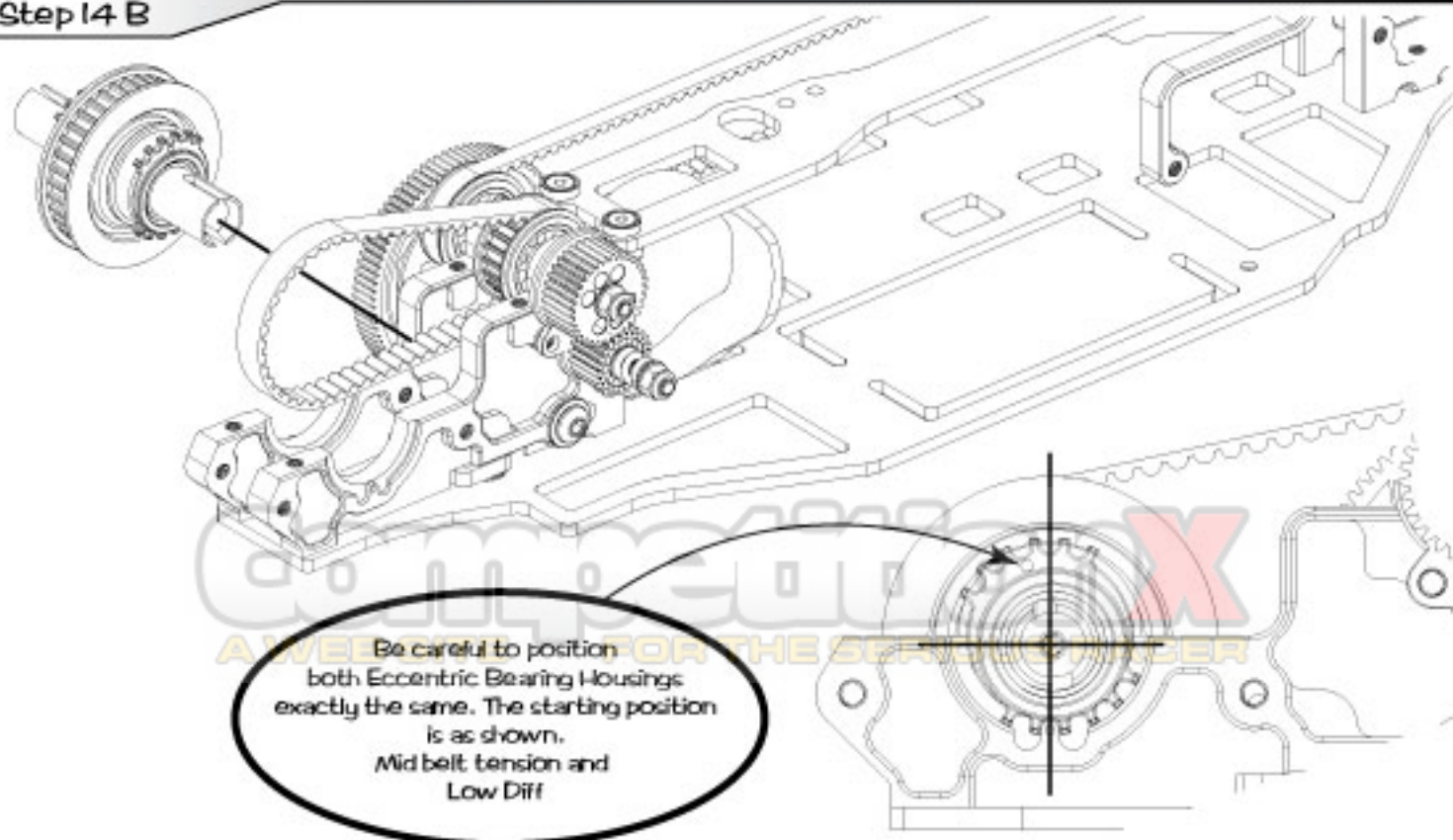



Step 14 C (Setting Rear Belt Tension)

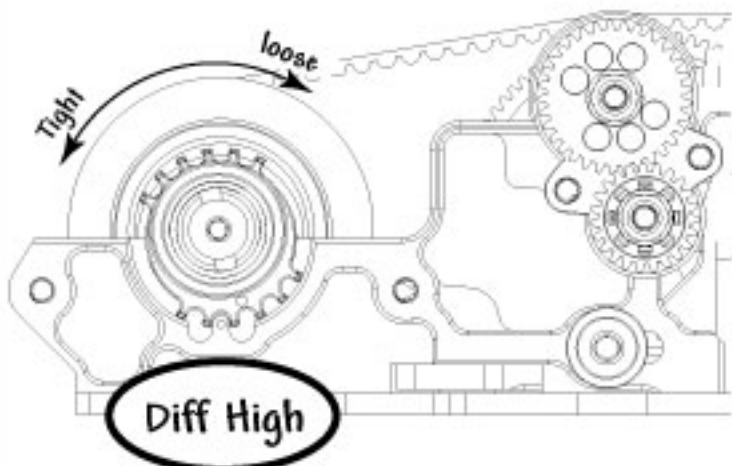
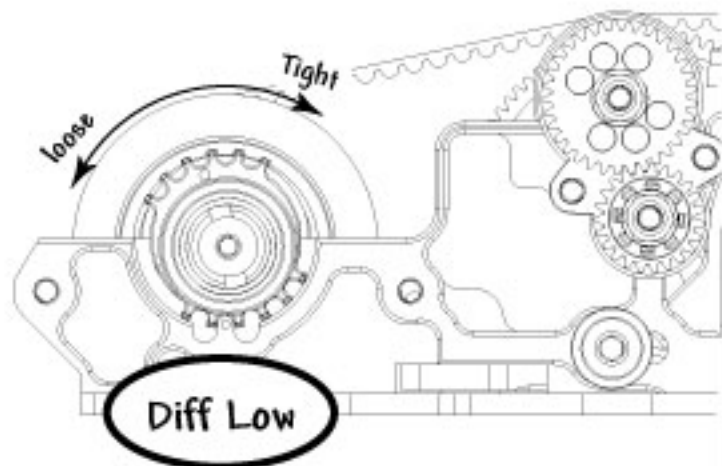

Step 14 D

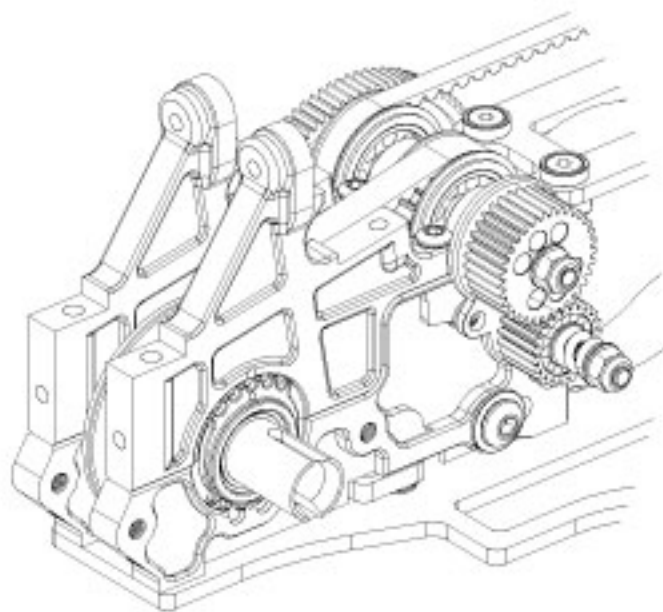
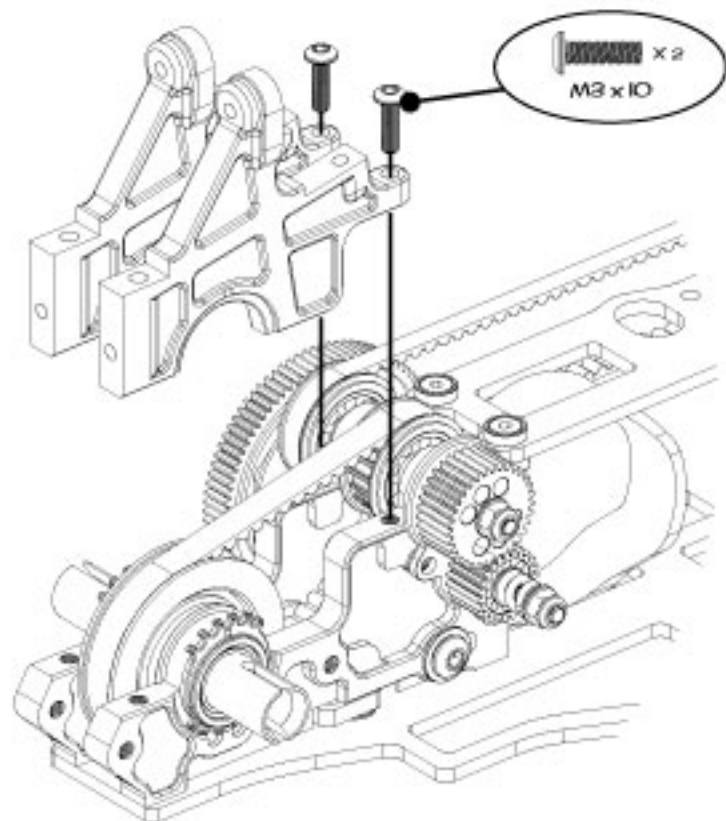

Step 15

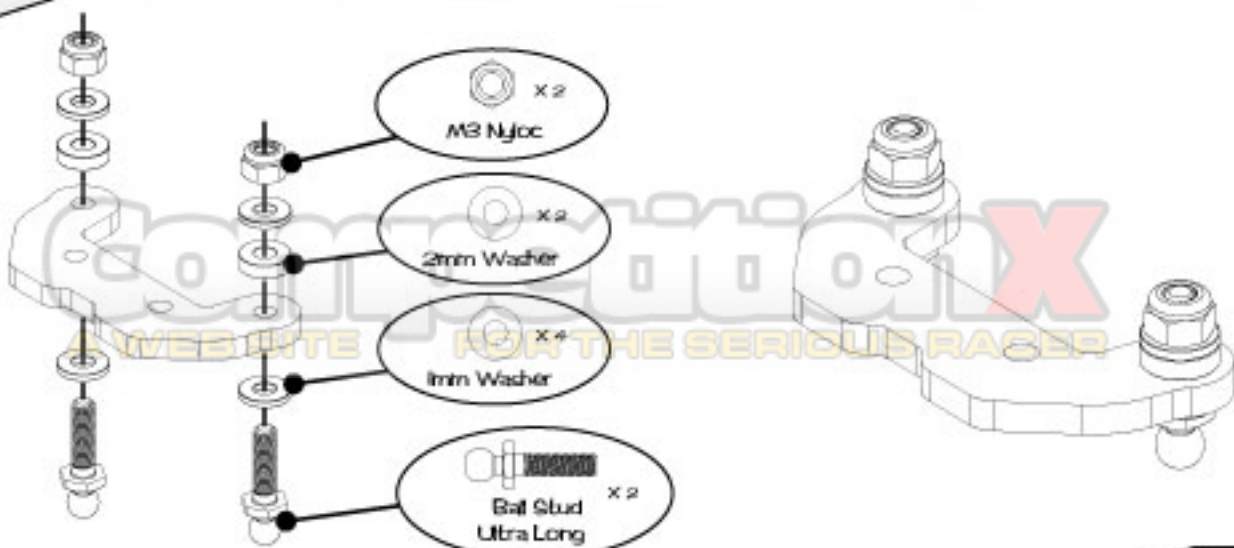

Step 16 A

**CAT**  
Competition - All - Terrain

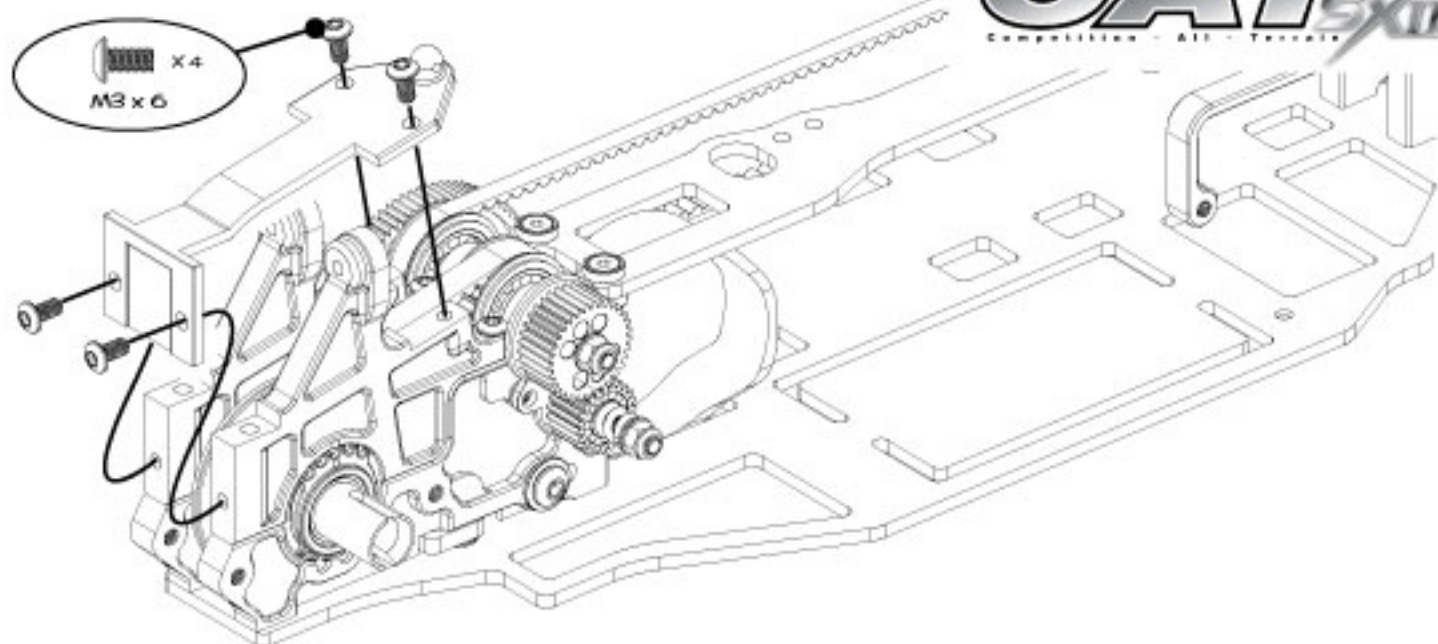

Step 16 B

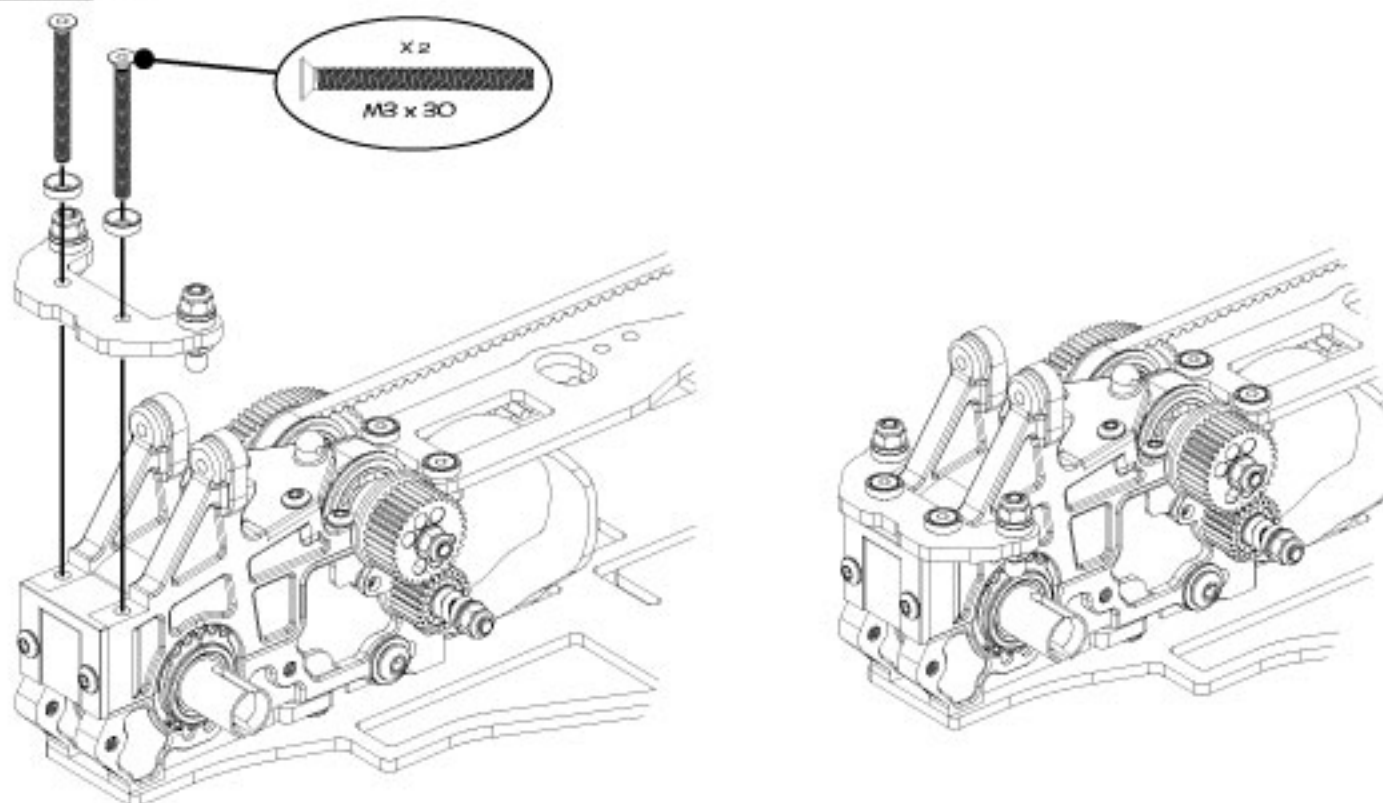

Step 17 A

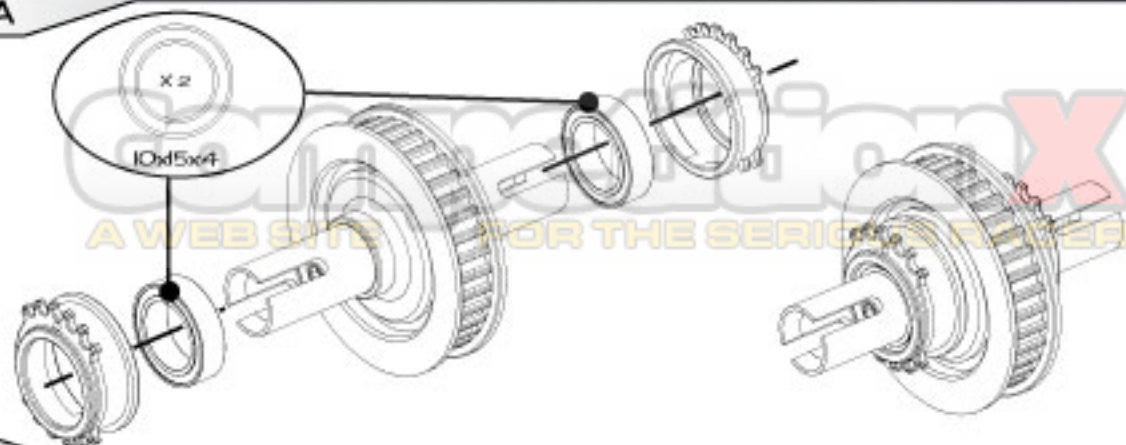



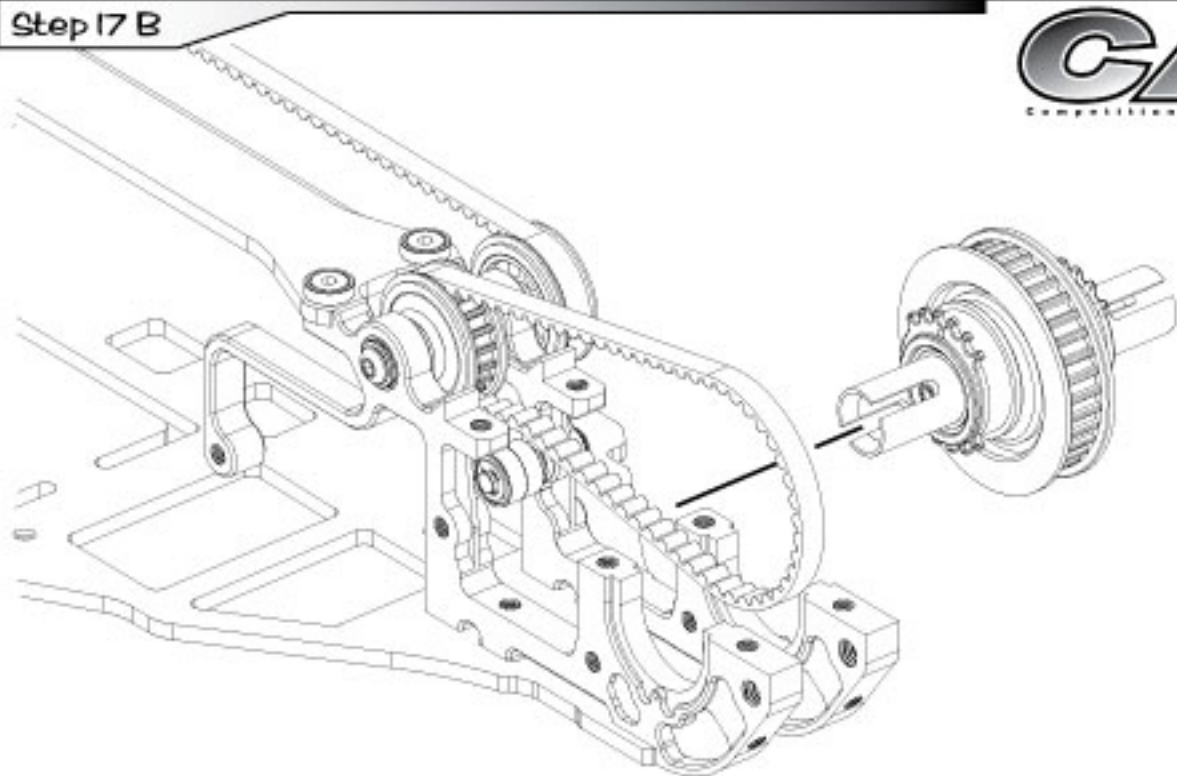

Be careful to position both Eccentric Bearing Housings exactly the same. The starting position is as shown. Mid belt tension and Low Diff

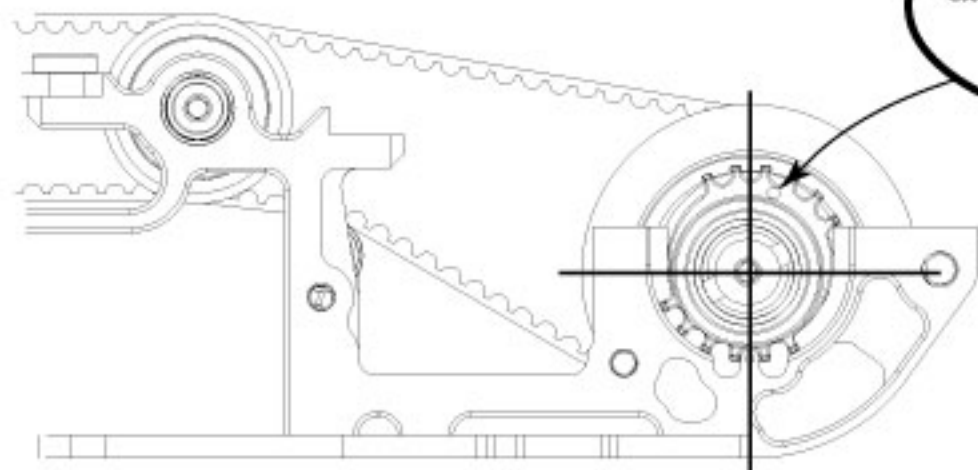

## Step 17 C (Setting Front Belt Tension)

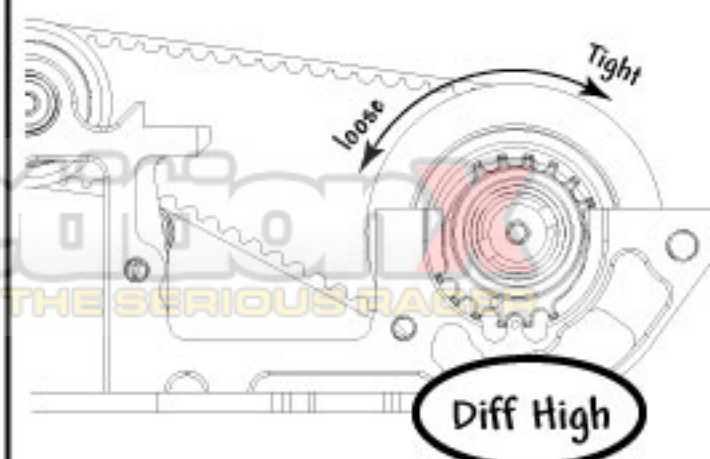
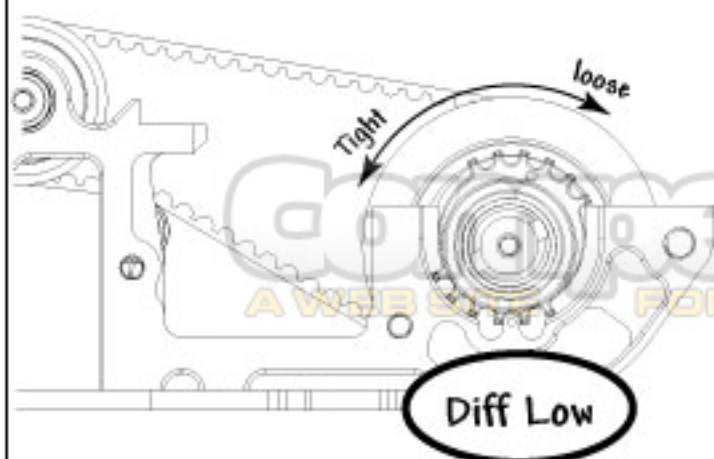

A WEB SITE FOR THE SERIOUS RACER



Step 17 D

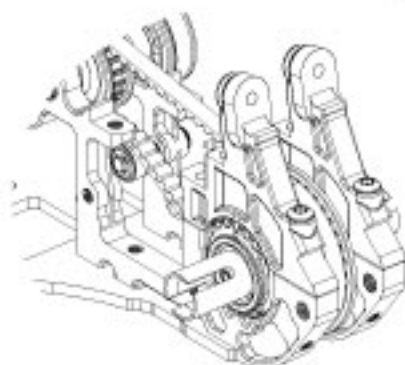
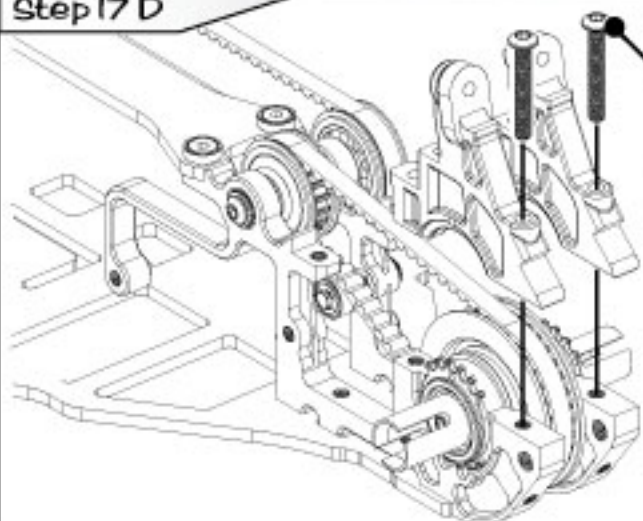

Step 18

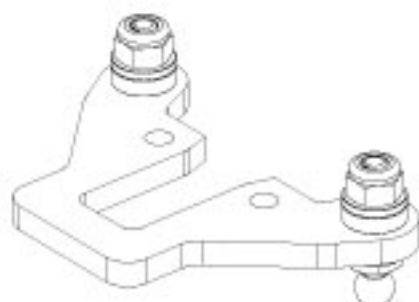
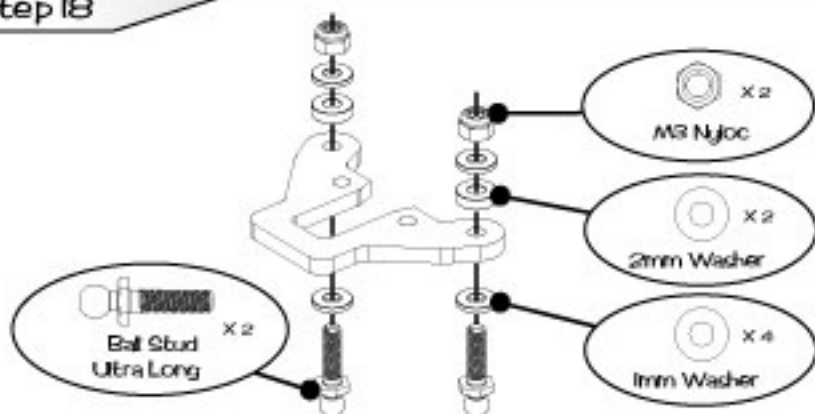

Step 19 A

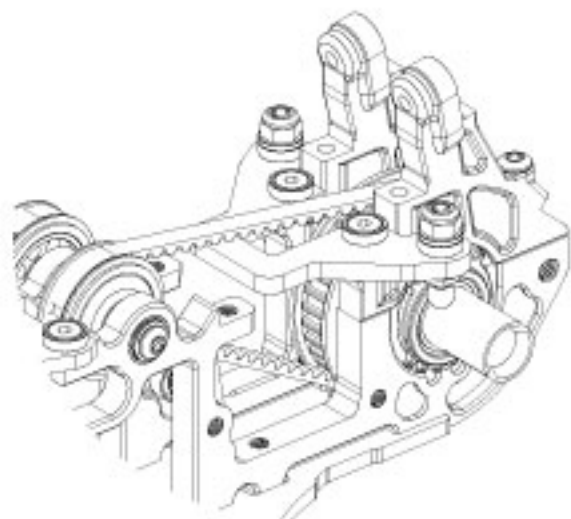
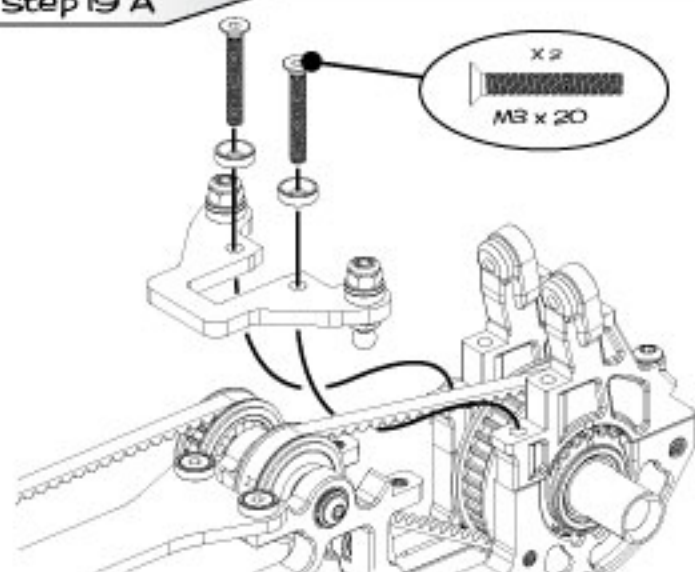

Step 19 B

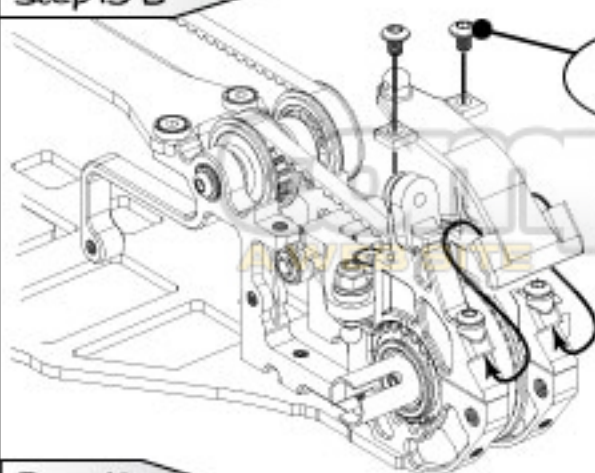

Now Check the  
Transmission Rotates  
Freely

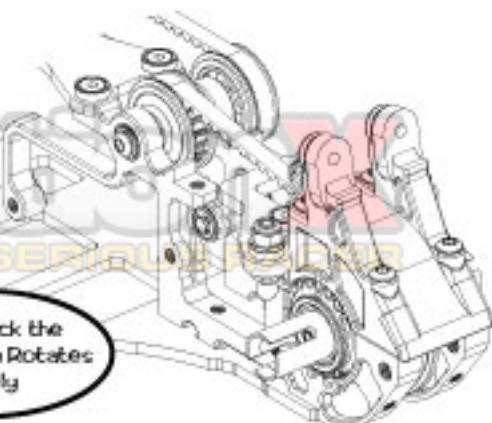

### Step 20 A

# CAT<sup>SKII</sup>

Competition - All - Terrain

**IMPORTANT**  
Cutouts in shock bracket  
MUST be on this side

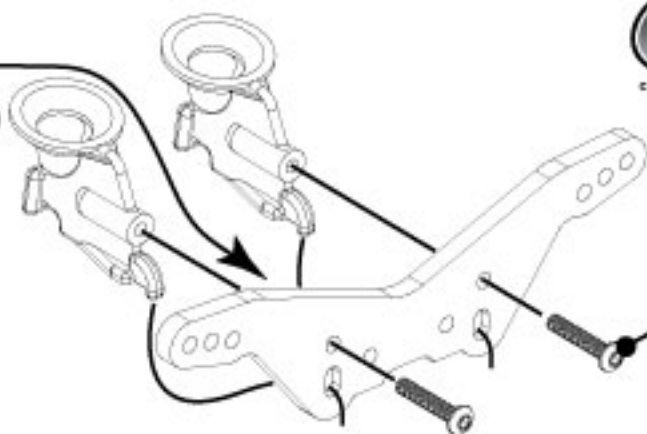

X 2

M3 x 16

### Step 20 B

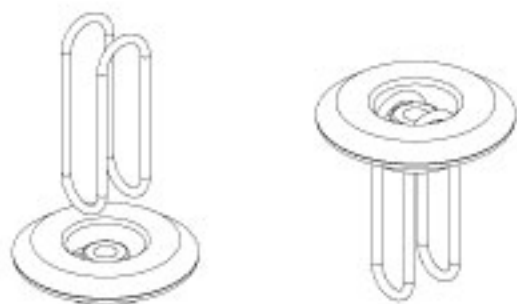

### Step 20 C

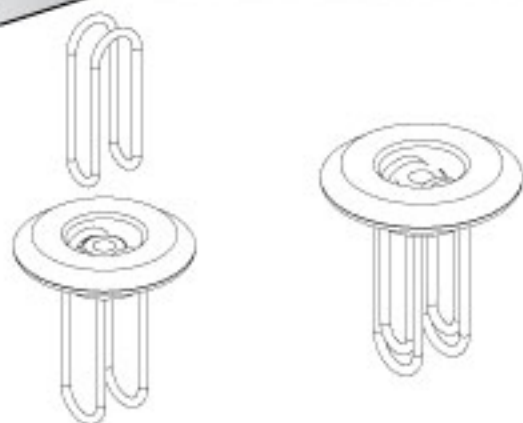

### Step 20 D

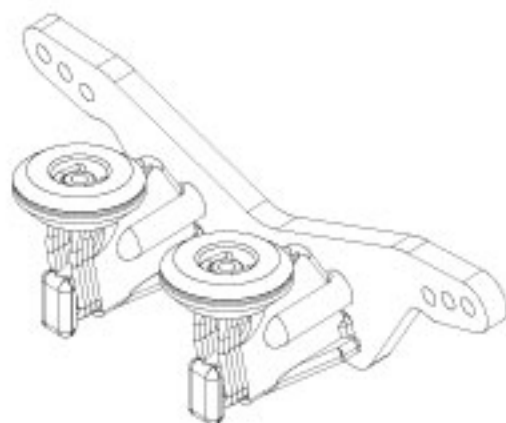
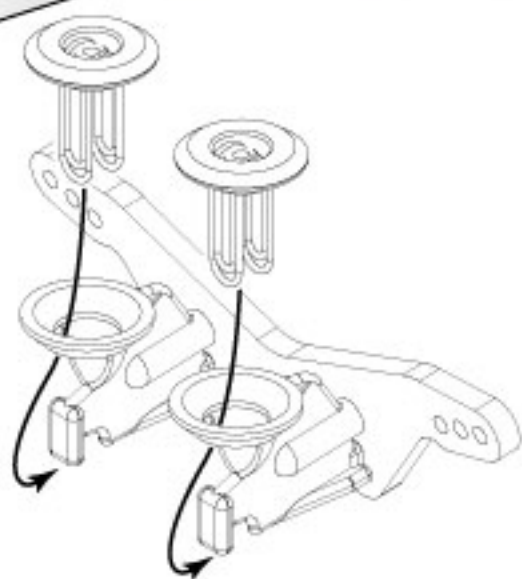

### Step 20 E

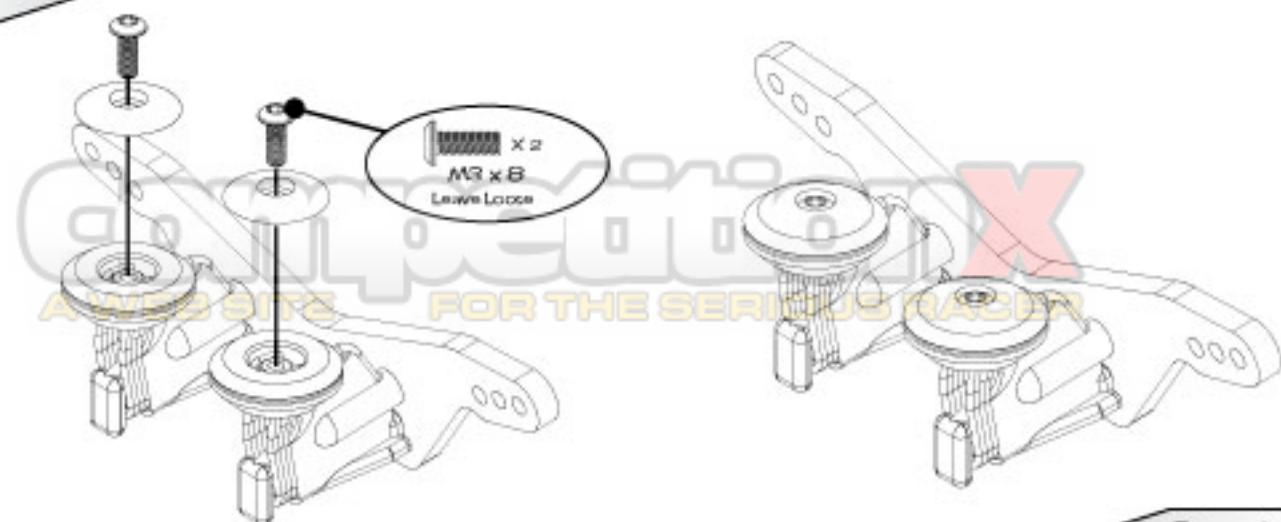

X 2  
M3 x 8  
Leave Loose



Step 21 A

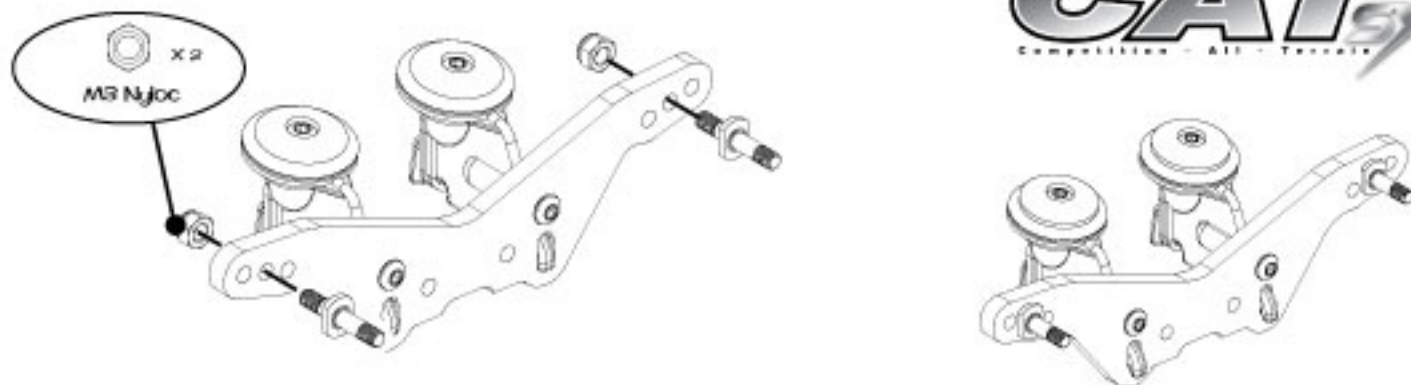

Step 21 B

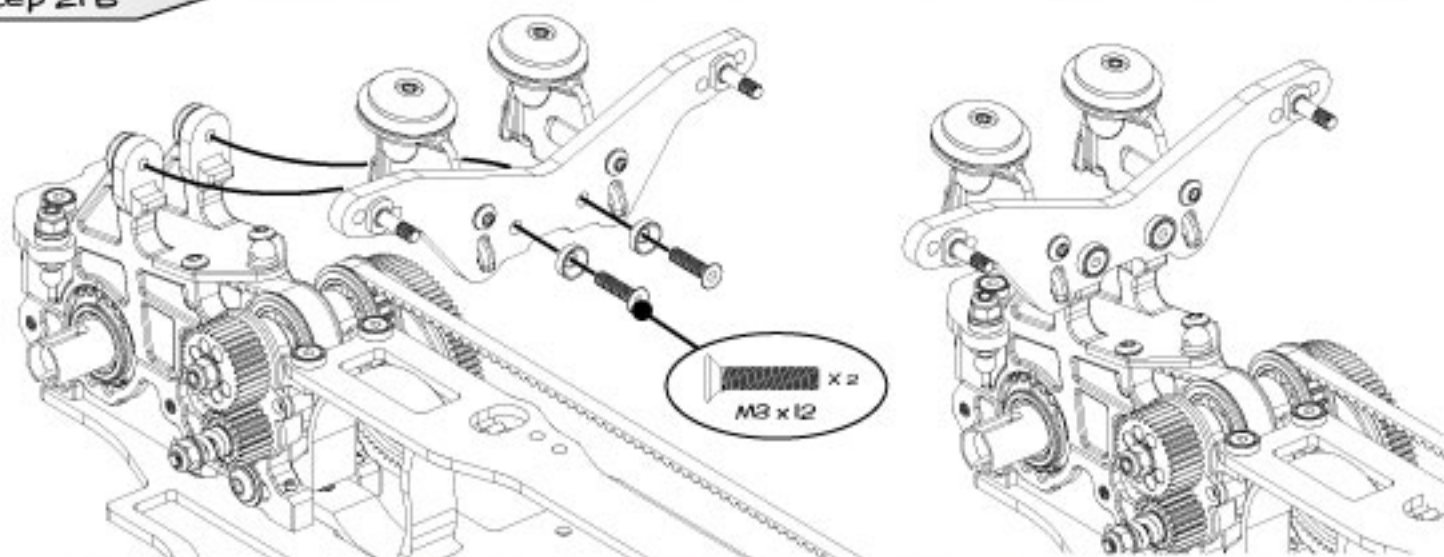

Step 22 A

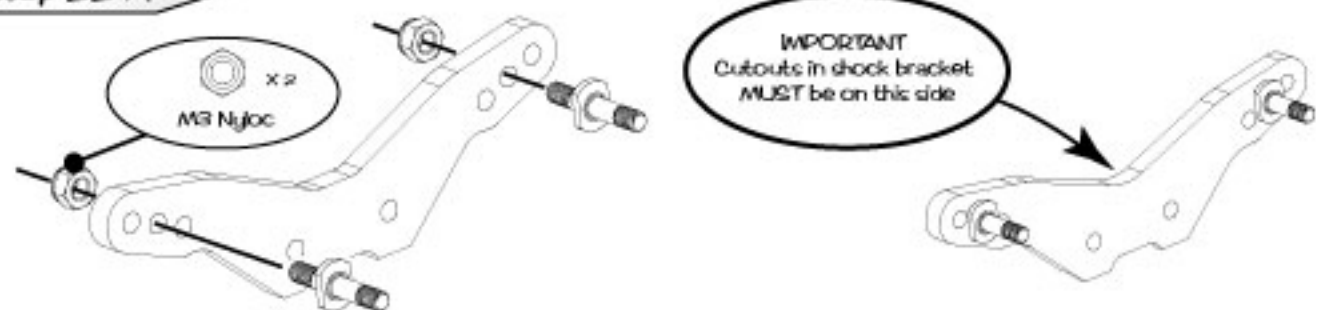

Step 22 B

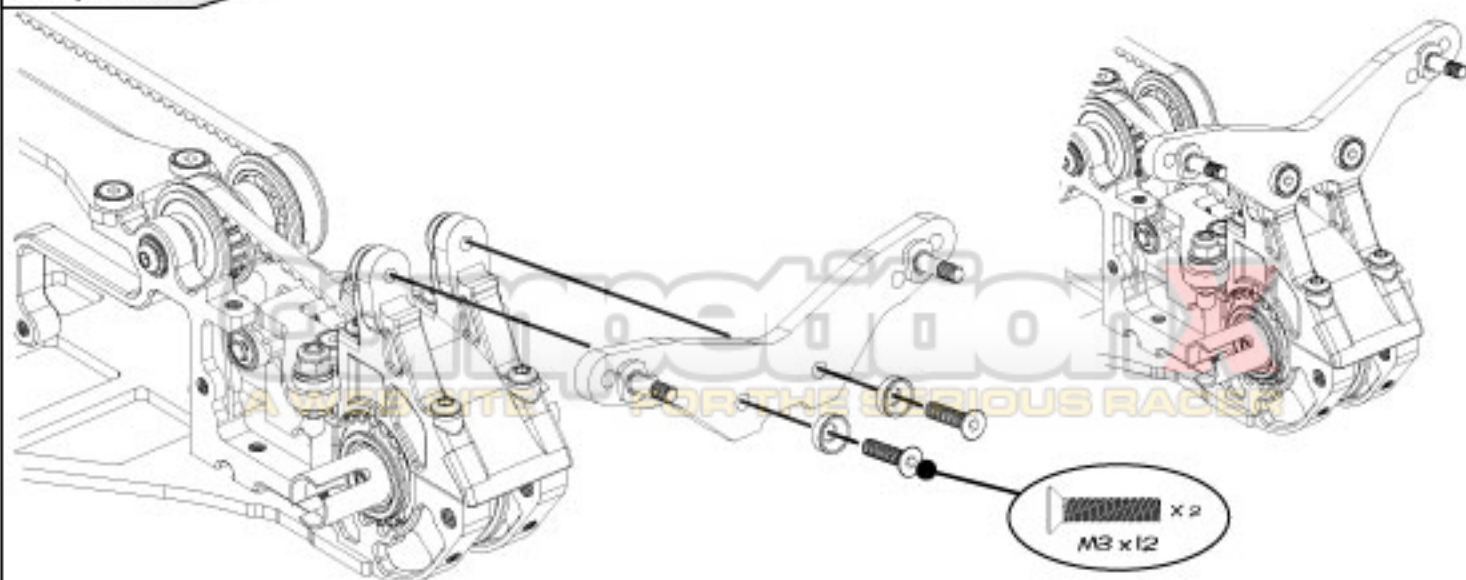

Step 23

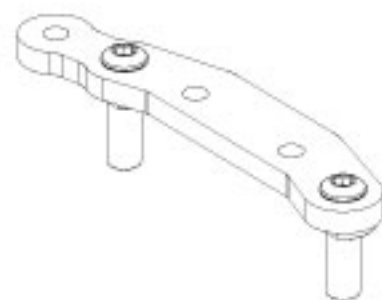
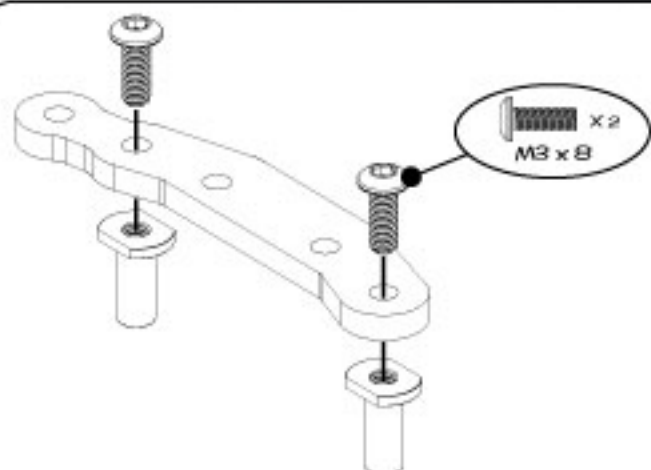

Step 24

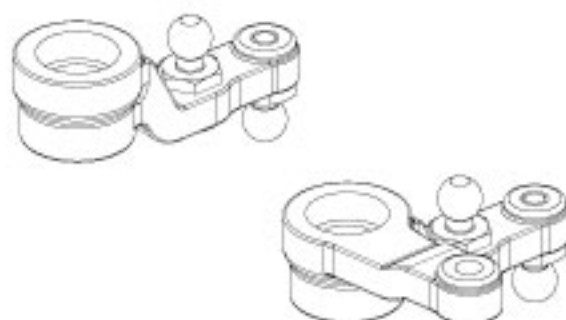
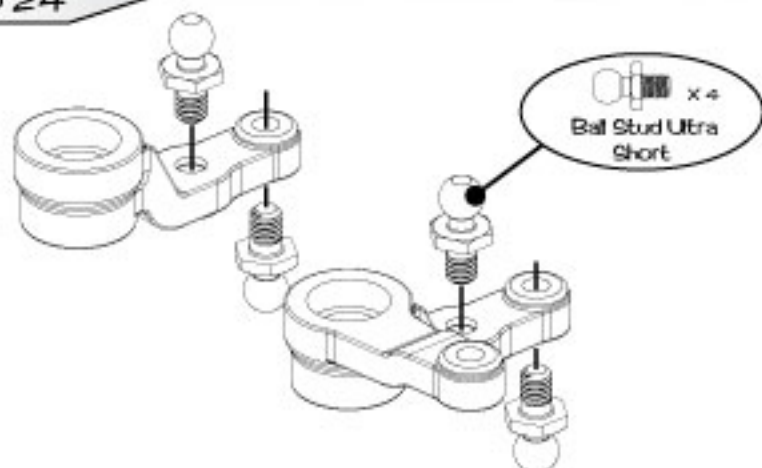

Step 25

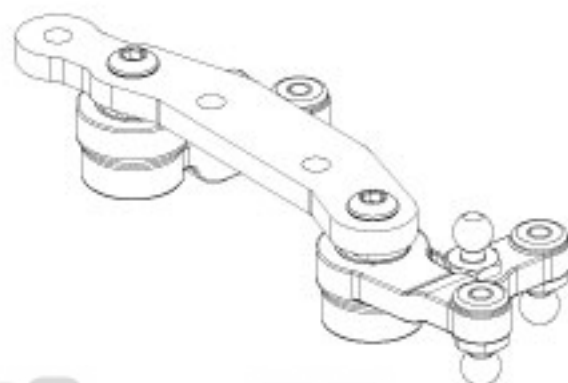
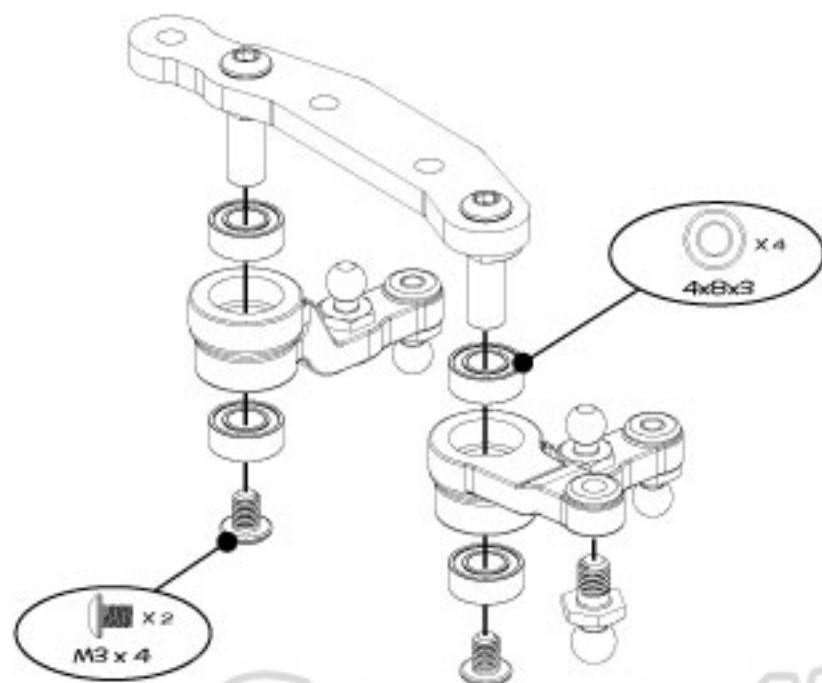

Step 26 A





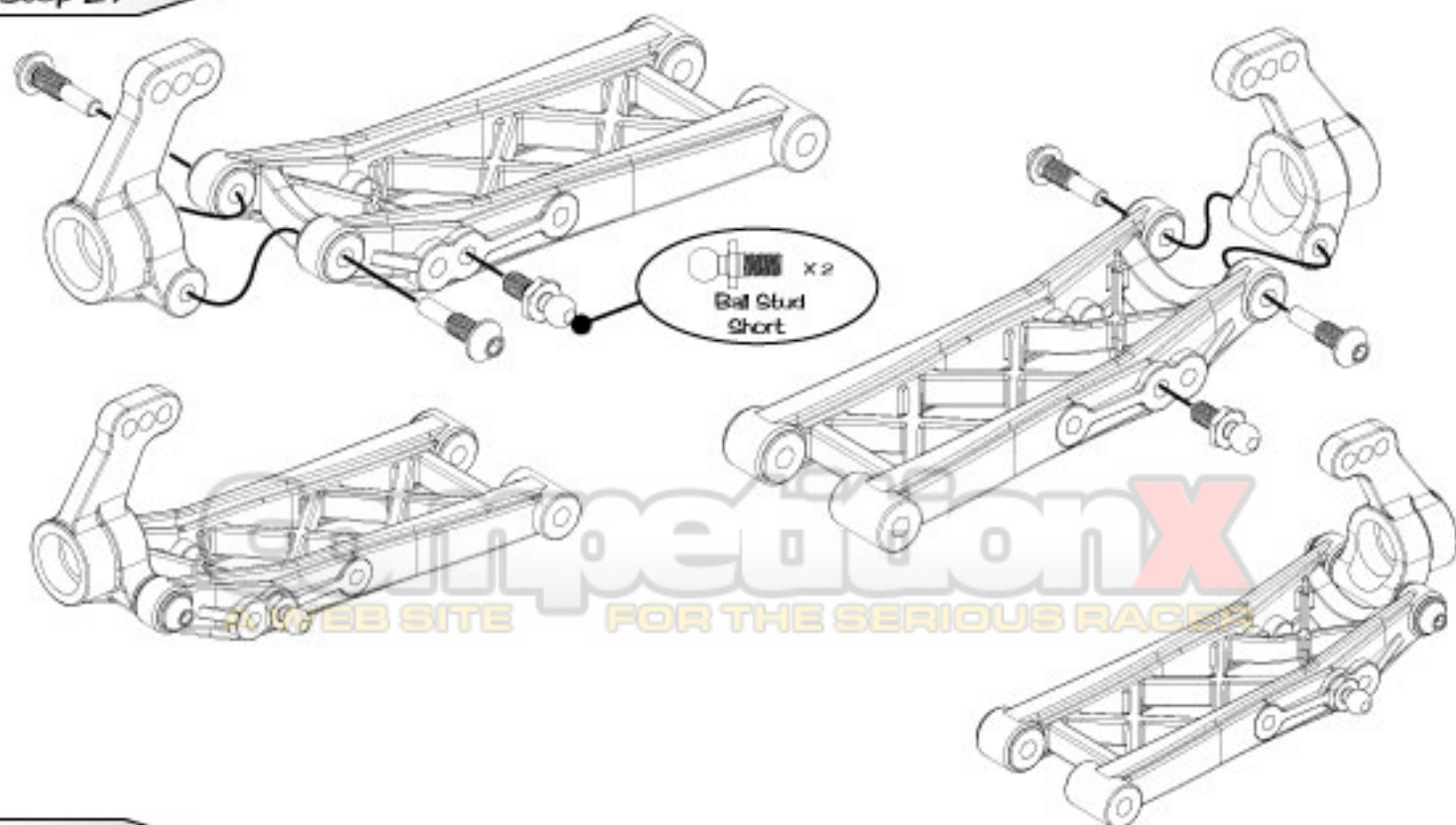
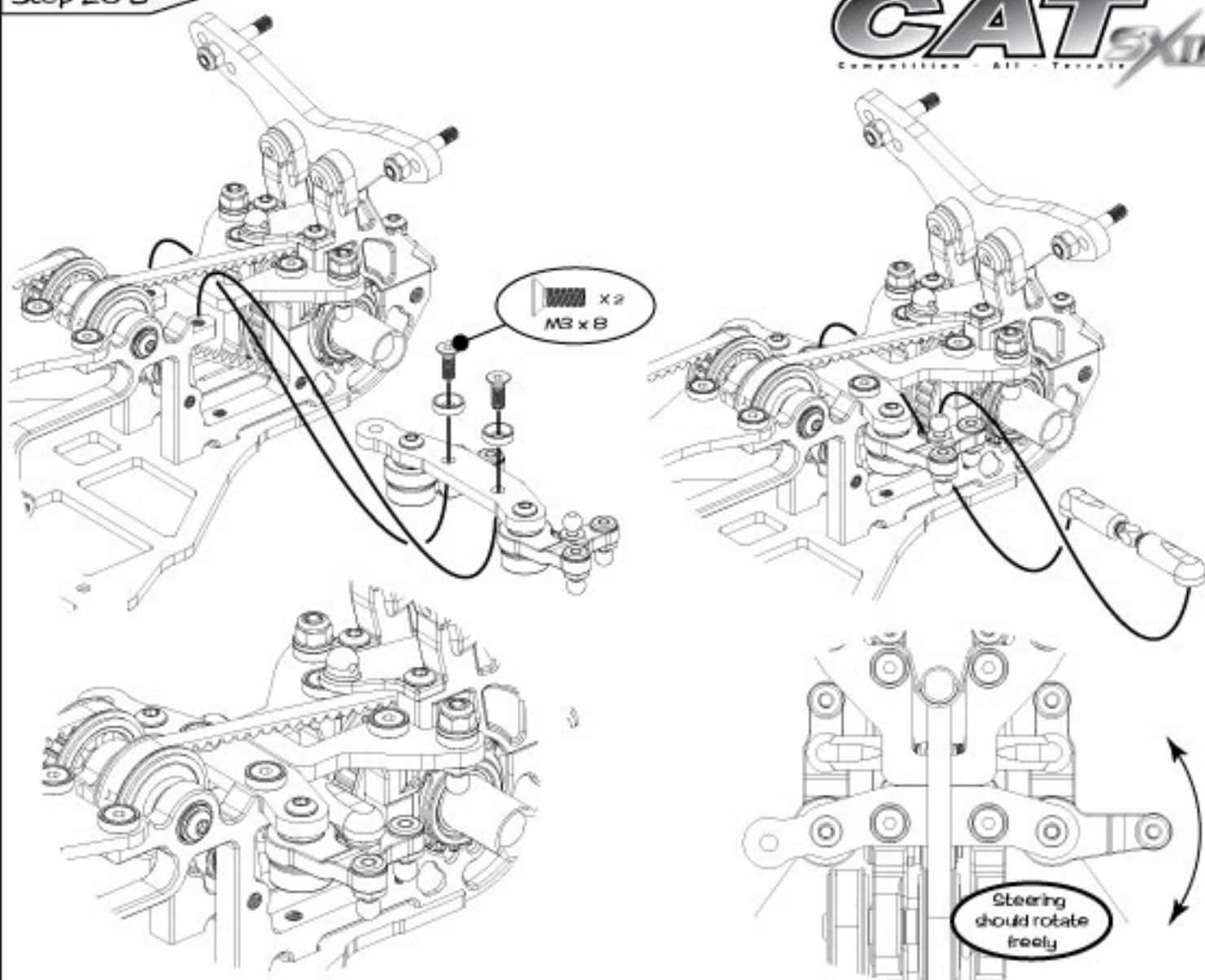

### Step 28

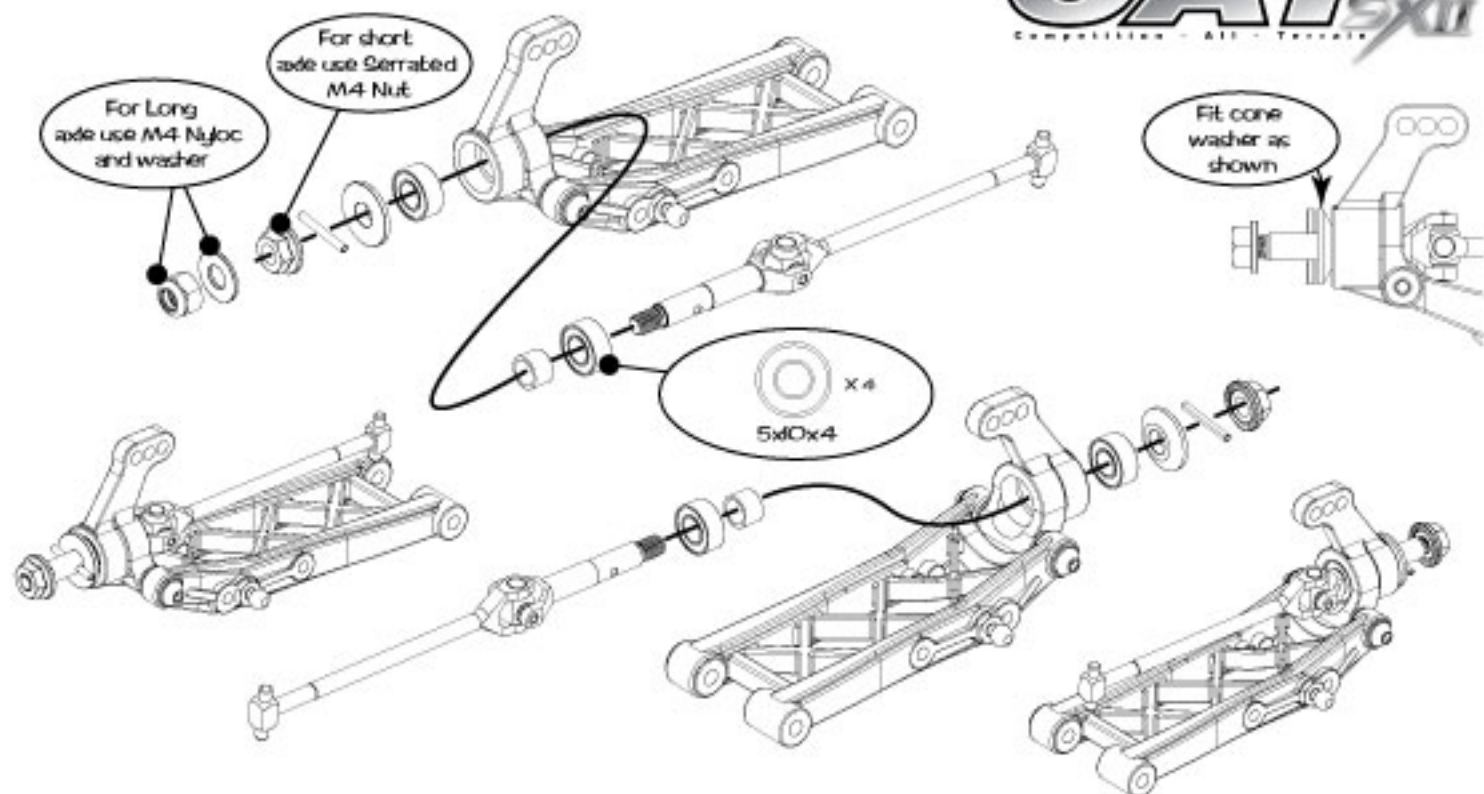

### Step 29 A

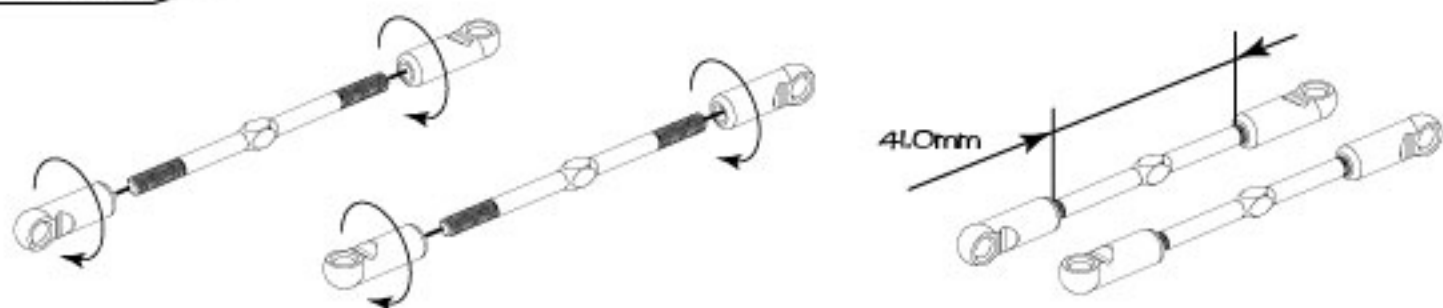

### Step 29 B

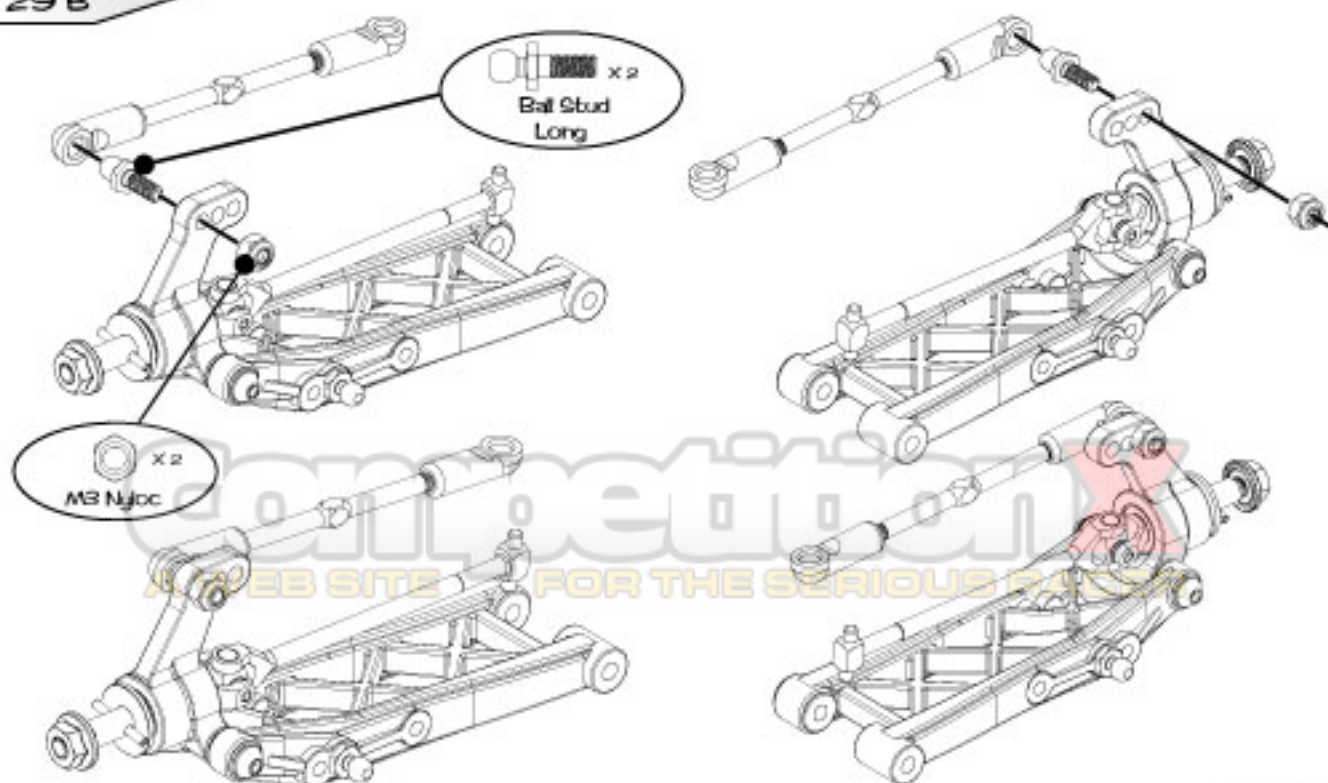



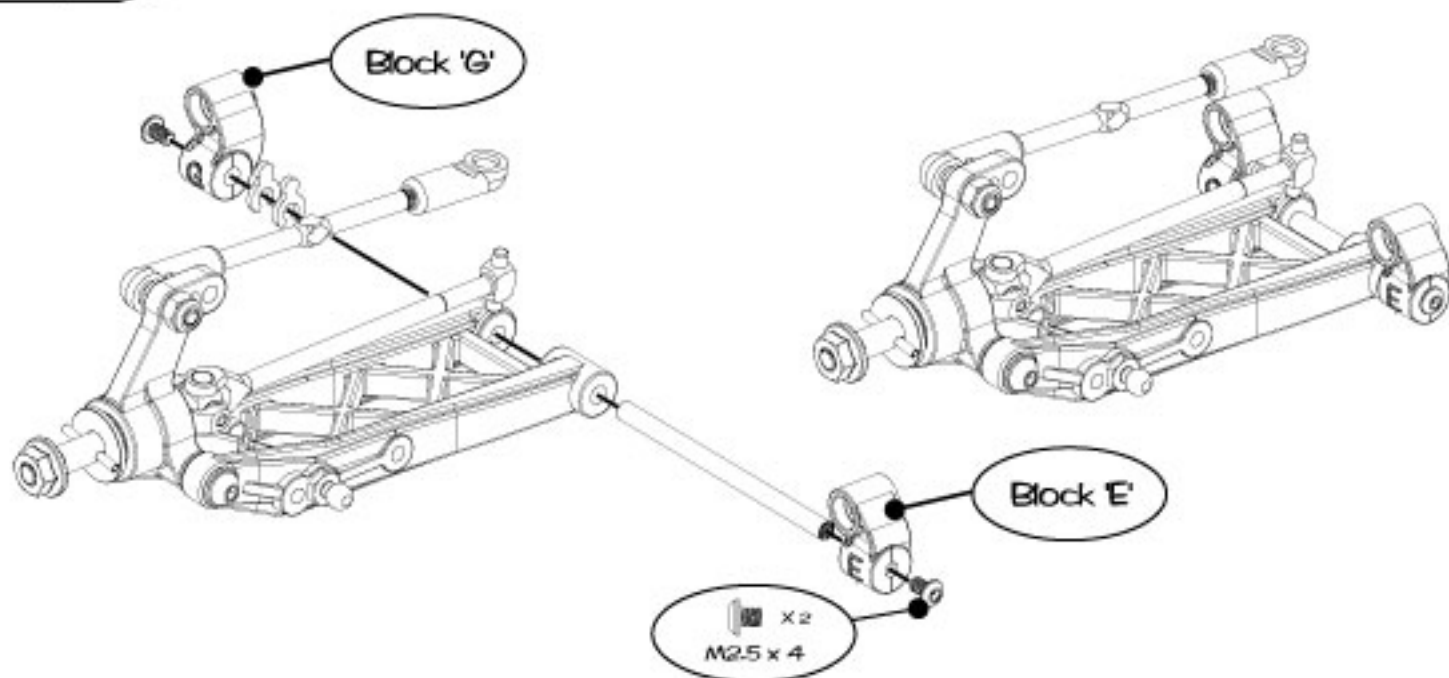
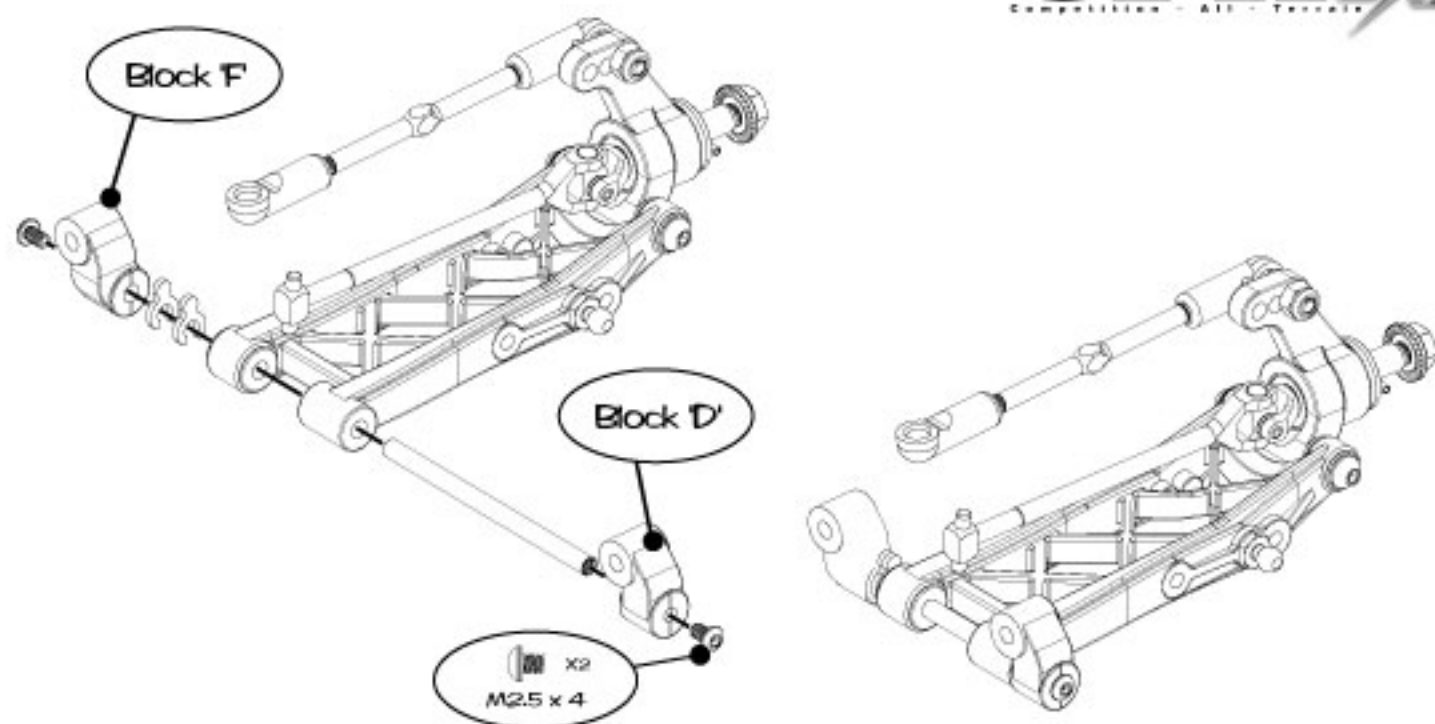

## Optional Alloy Pivot Blocks

Alloy Block Susp Set  
U3517



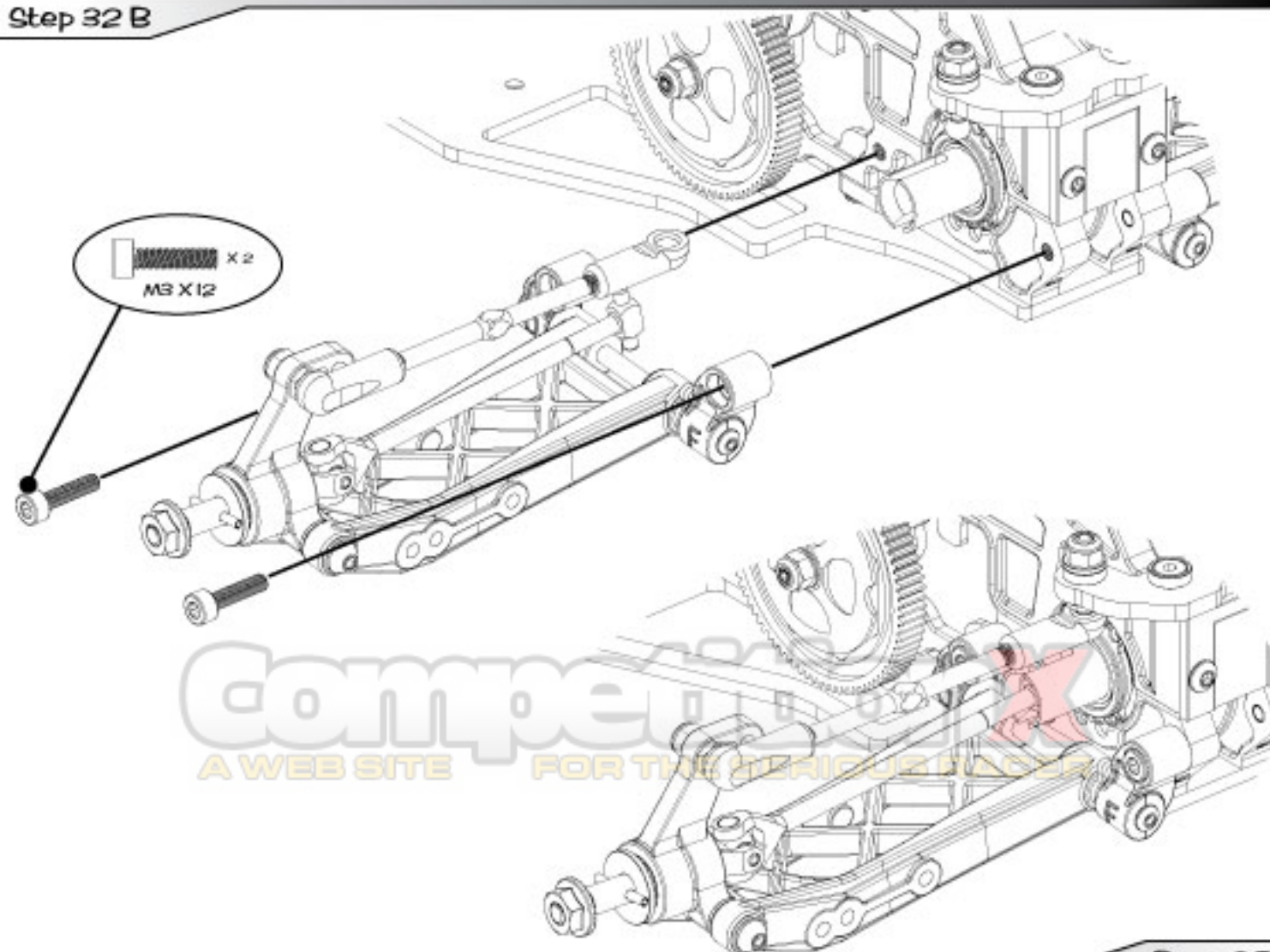
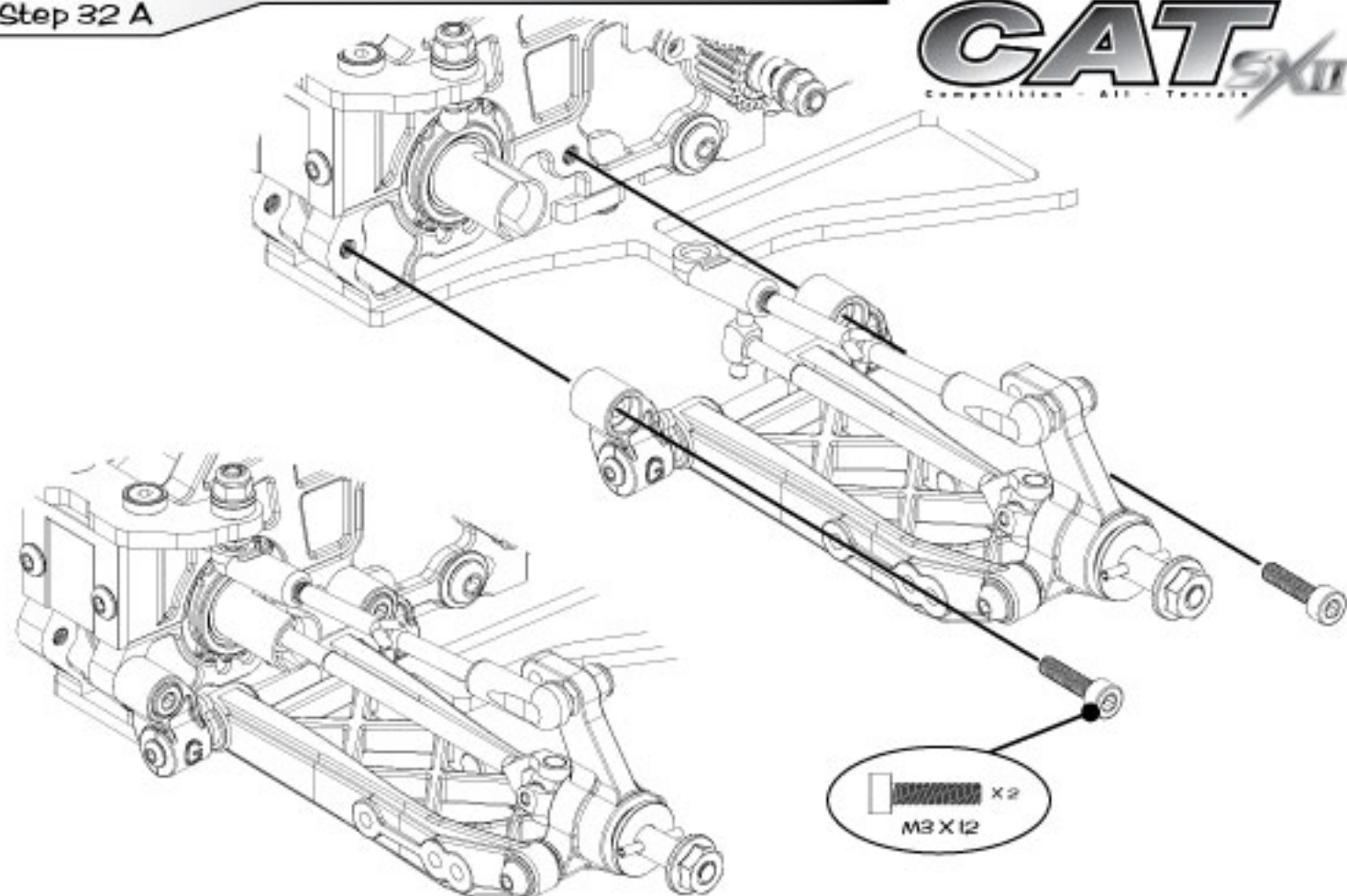



Step 33

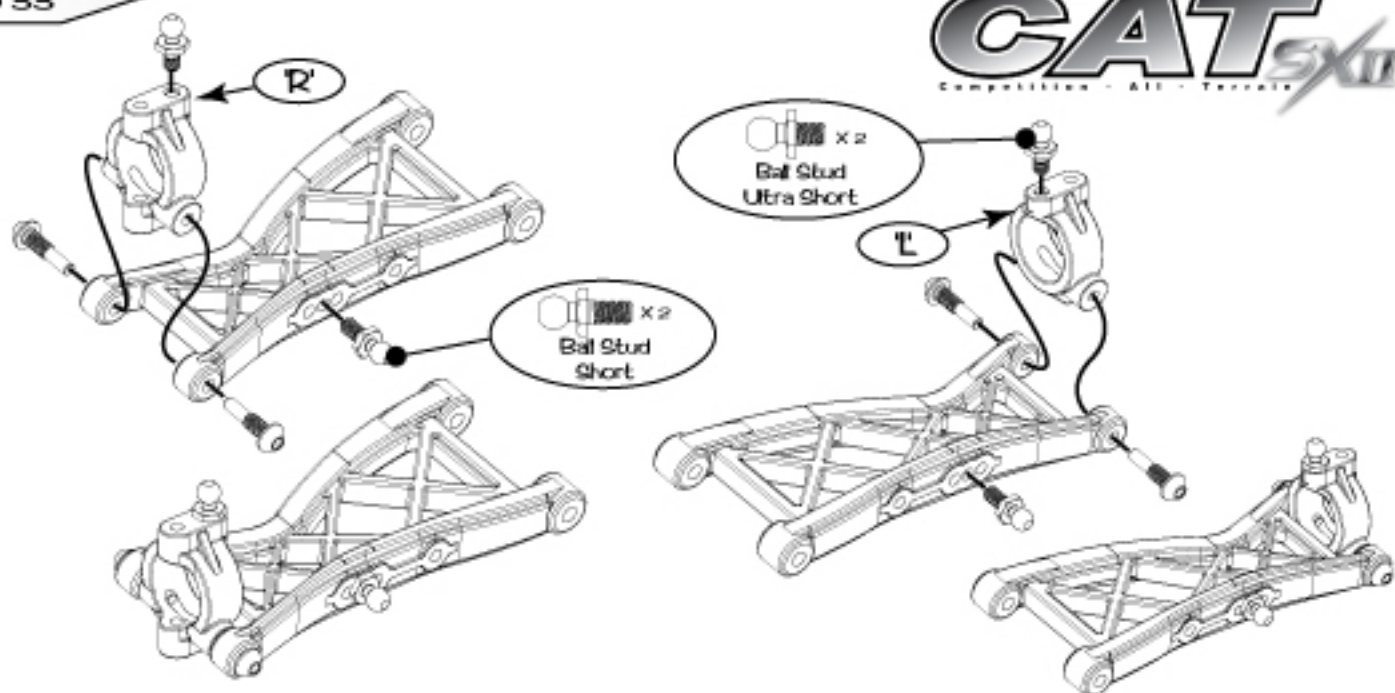

Step 34 A

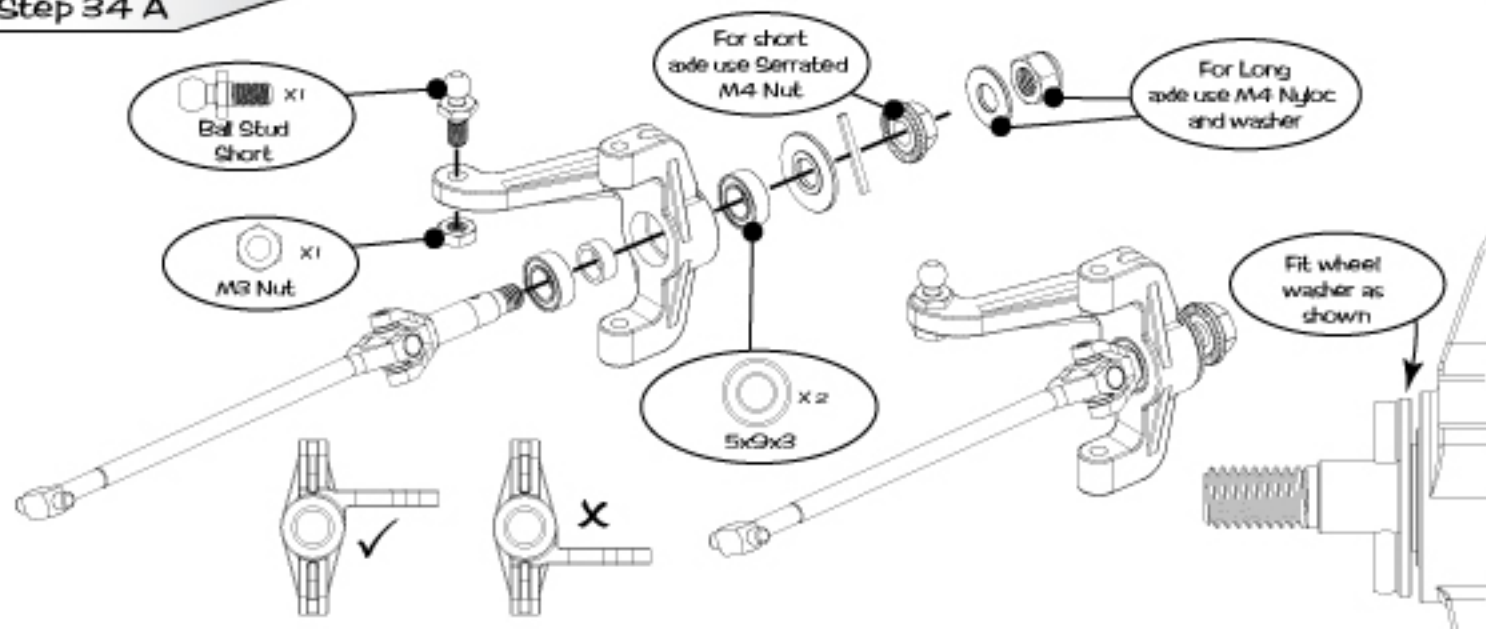

Step 34 B

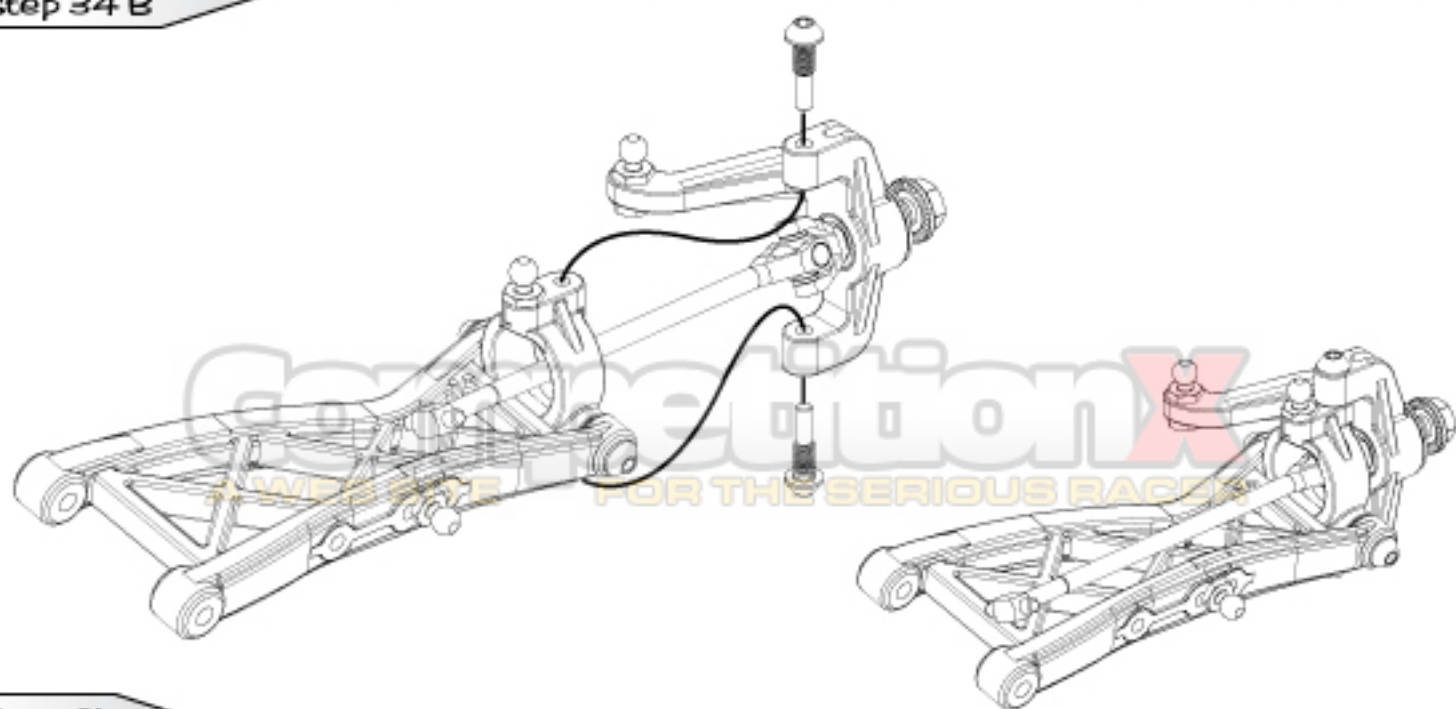

Step 35 A

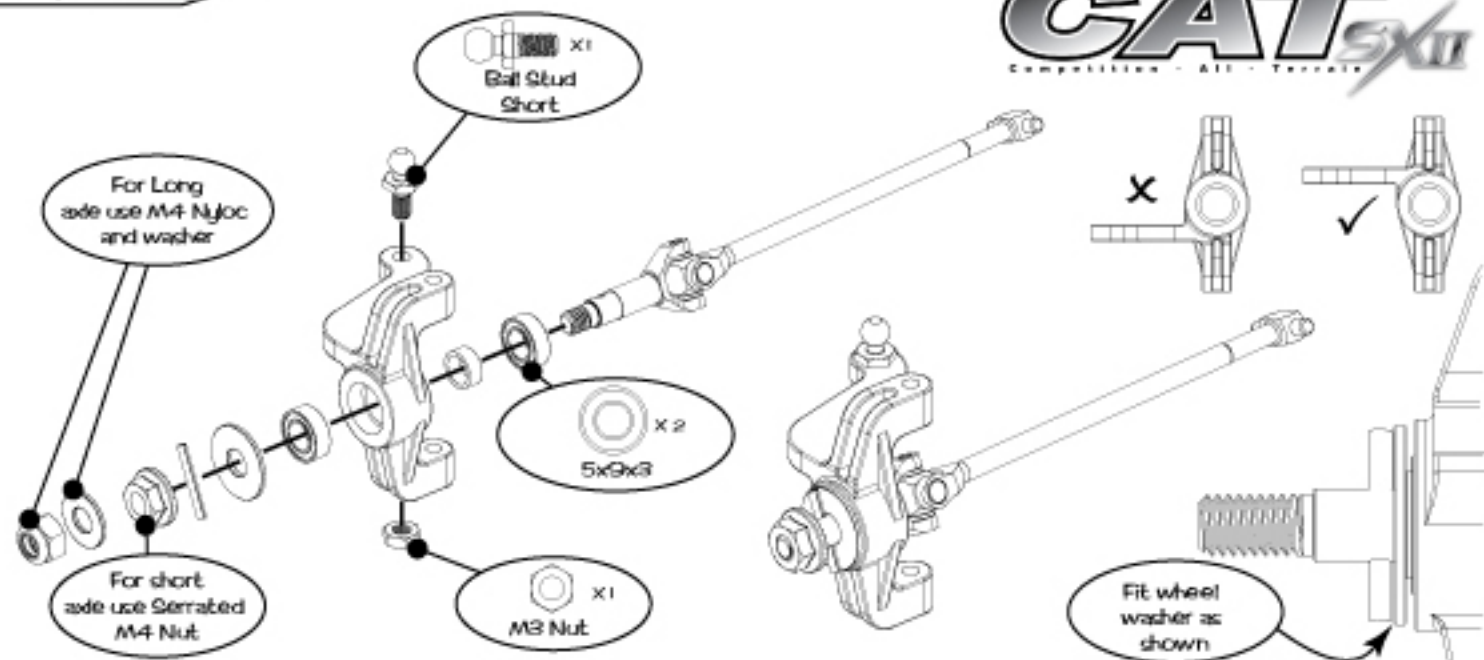

Step 35 B

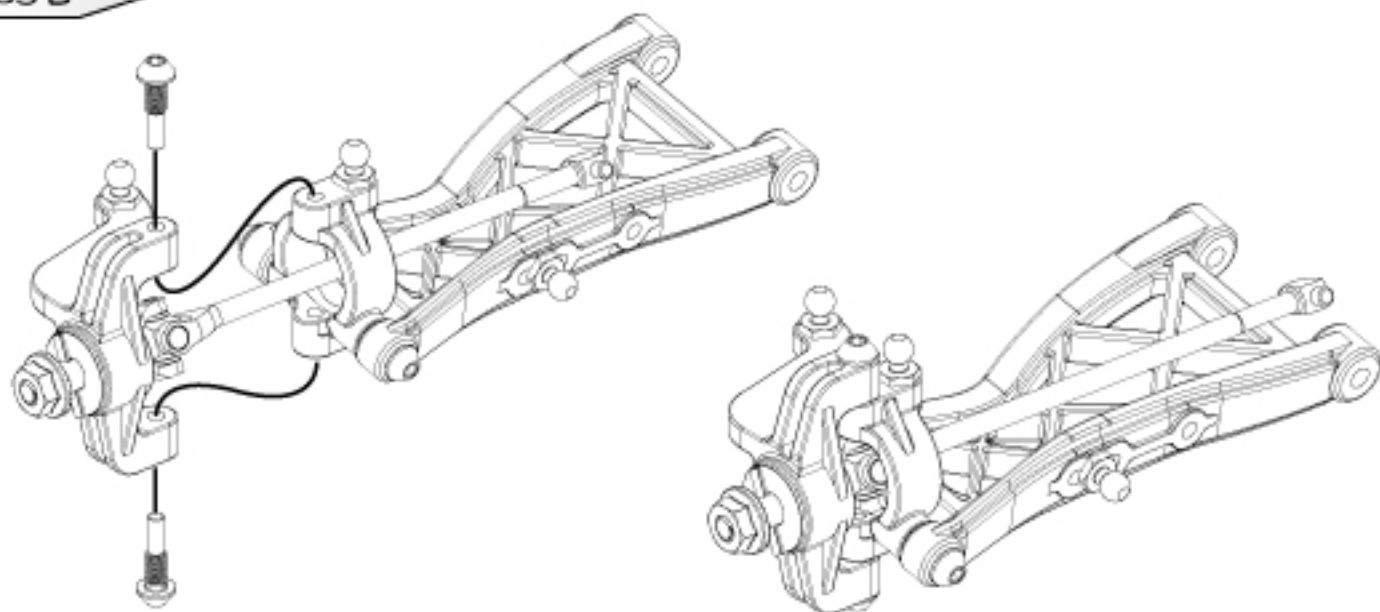

Step 36 A

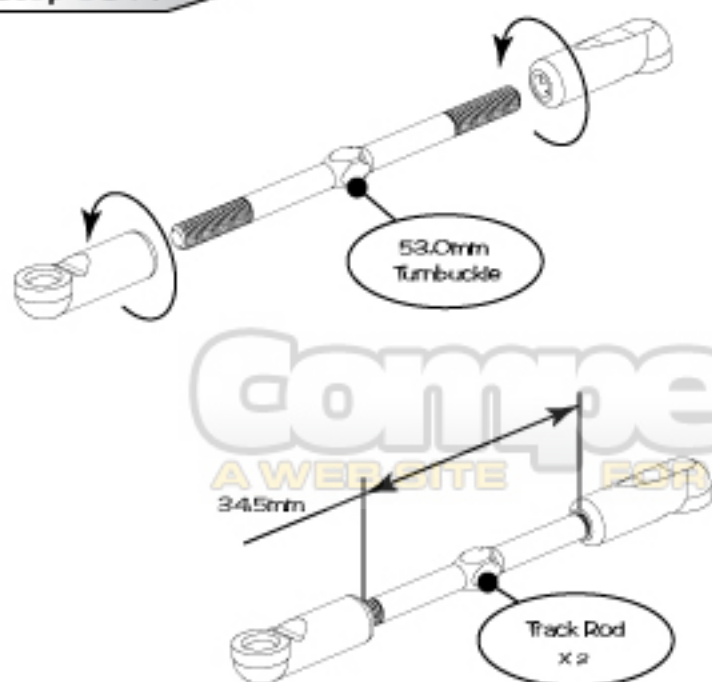

Step 36 B

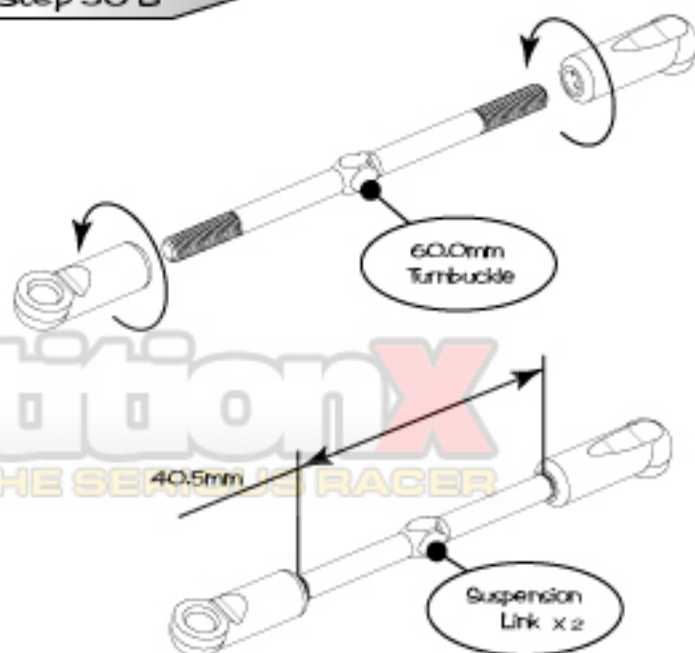

Competition X  
 A WEBSITE FOR THE SERIOUS RACER



Step 36 C

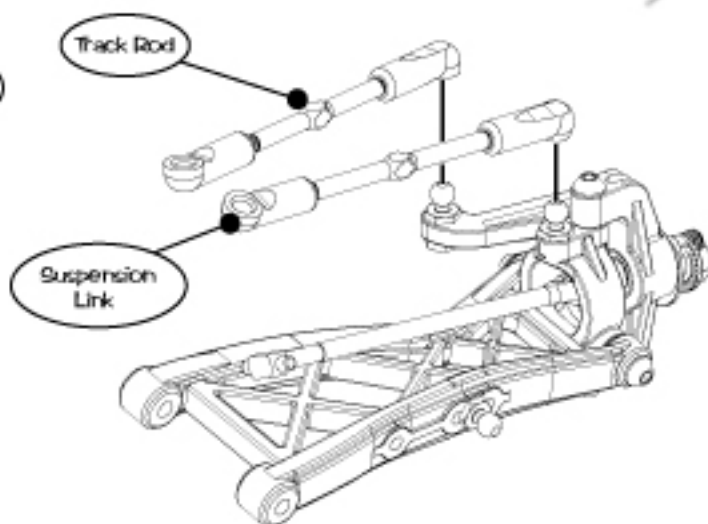
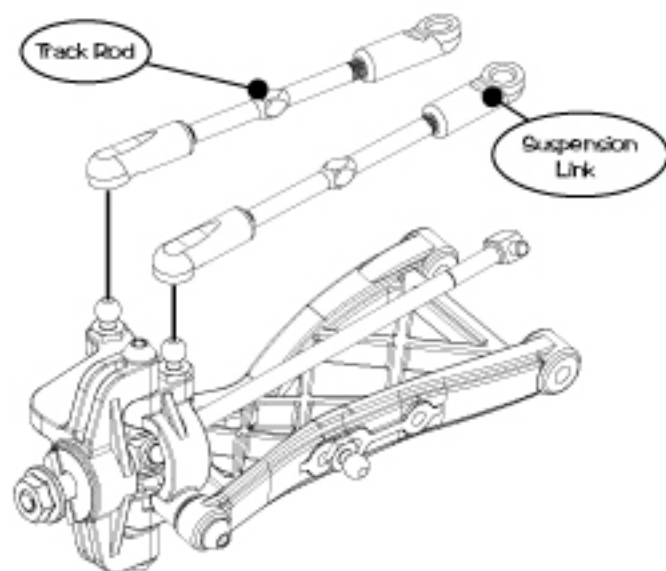

Step 37

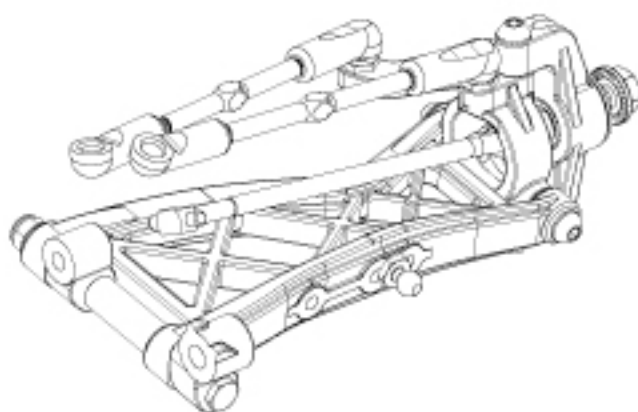
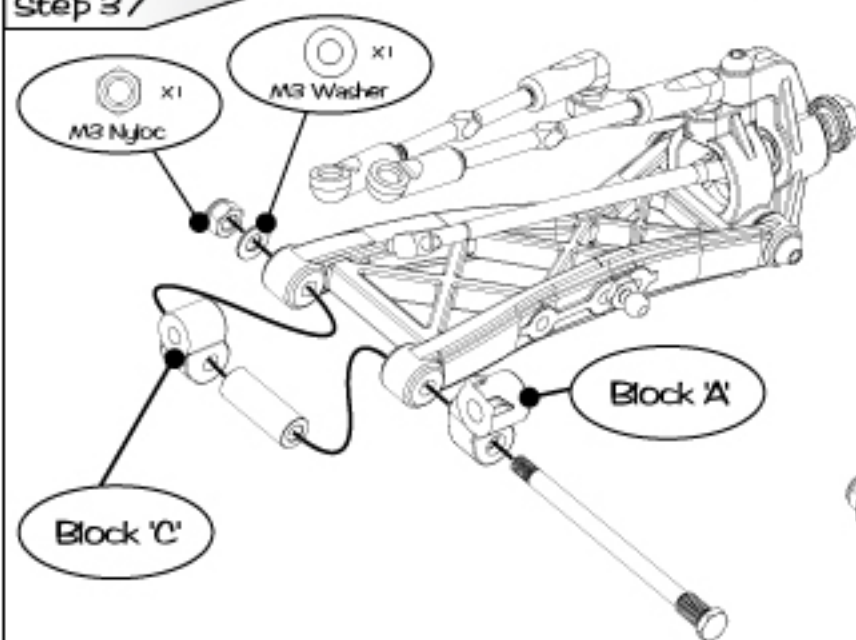

Step 38

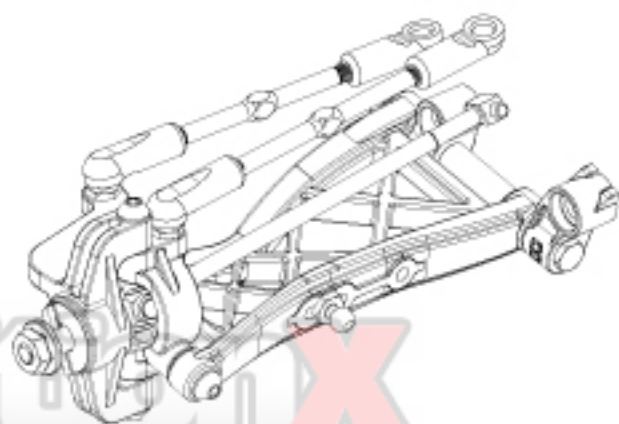
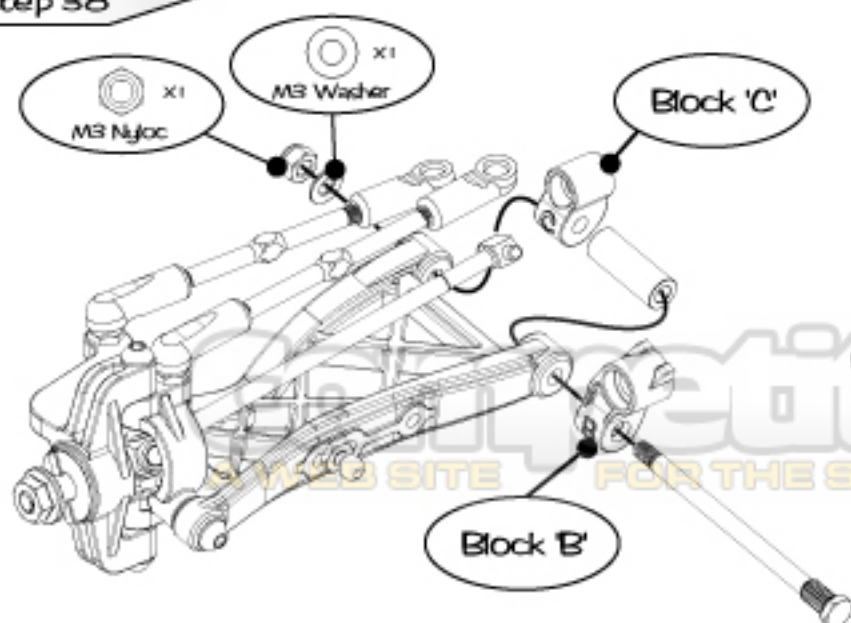

### Step 39 A

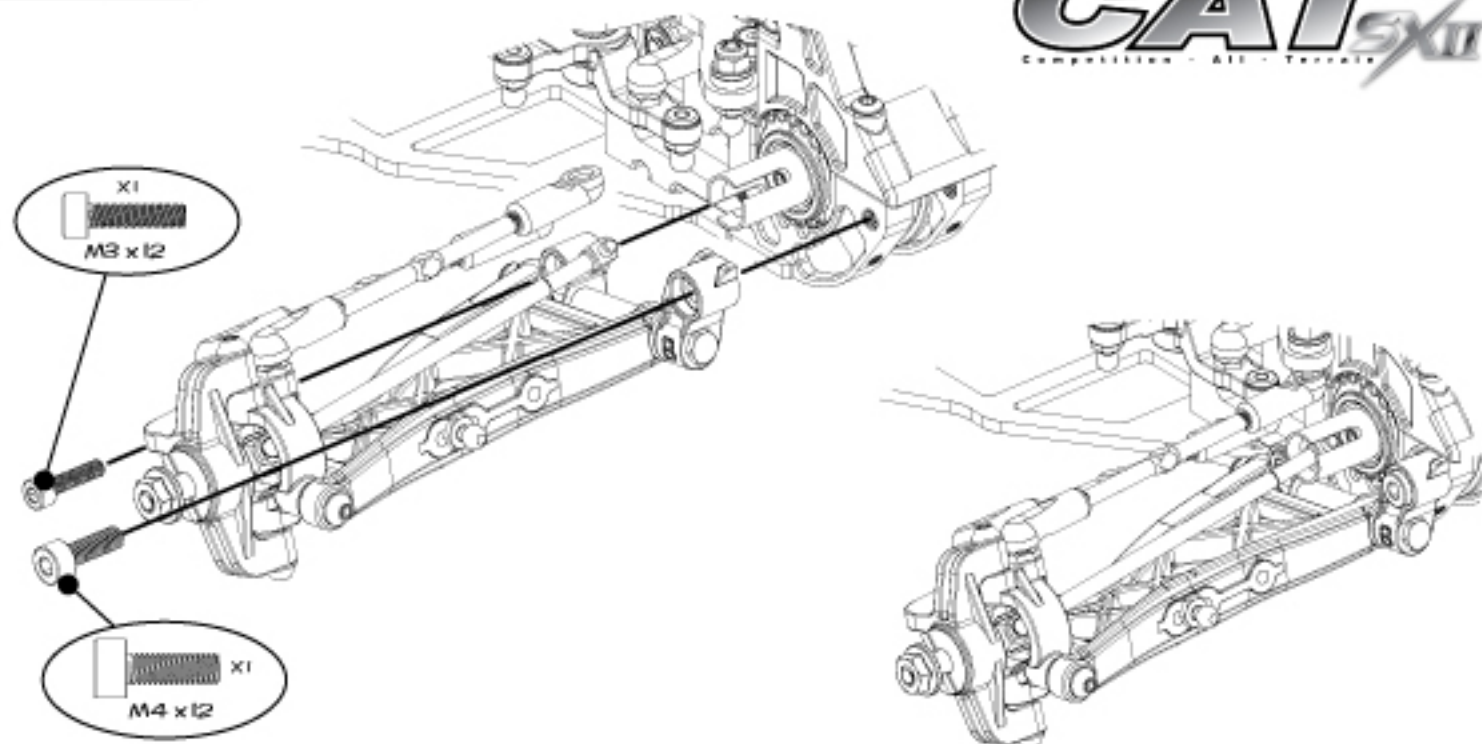

### Step 39 B

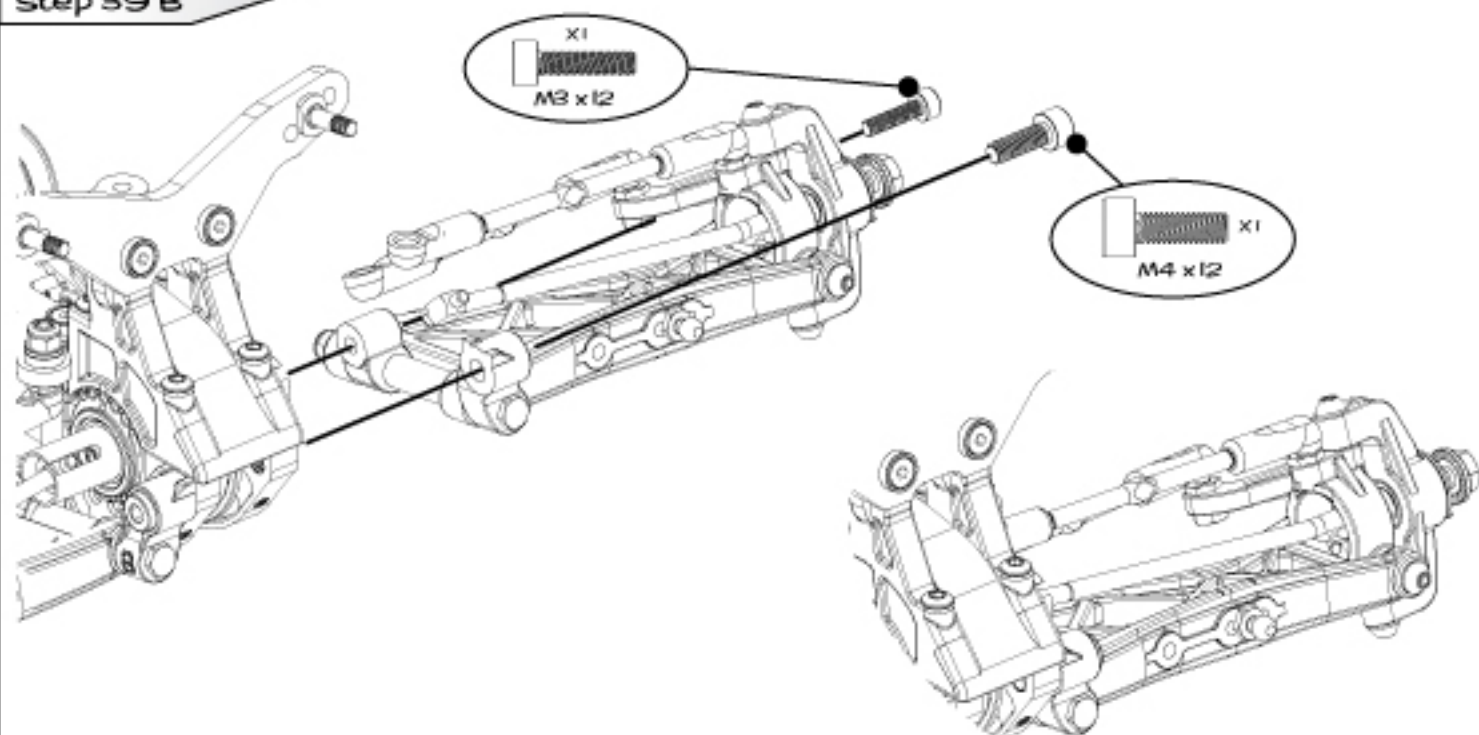

### Optional Alloy Pivot Blocks

Pivot Block M4 Front 10 degree - Cat SX  
UB556



Pivot Block: Front - Cat SX pr  
U3304



Pivot Block M4 Front 75 degree - Cat SX  
UB603





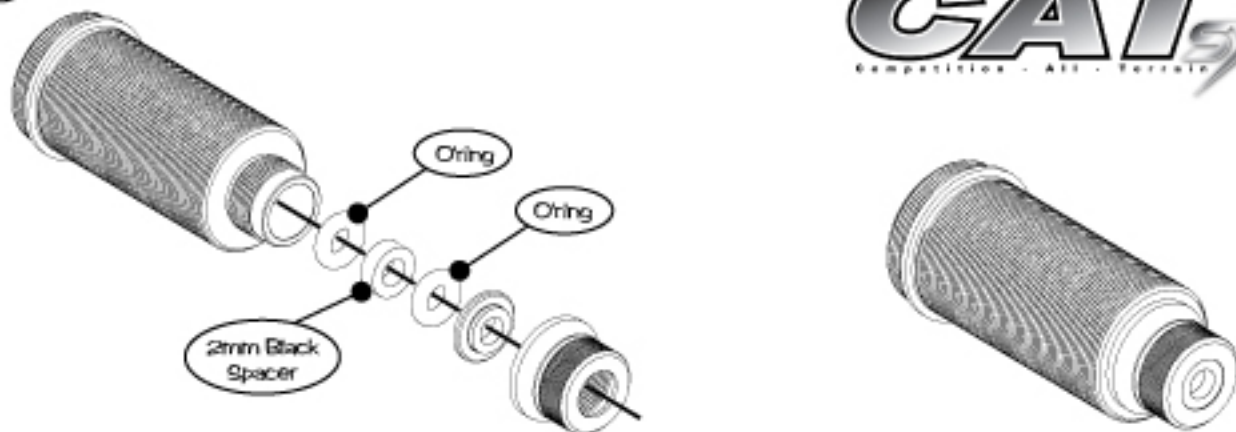

Piston Recess this side

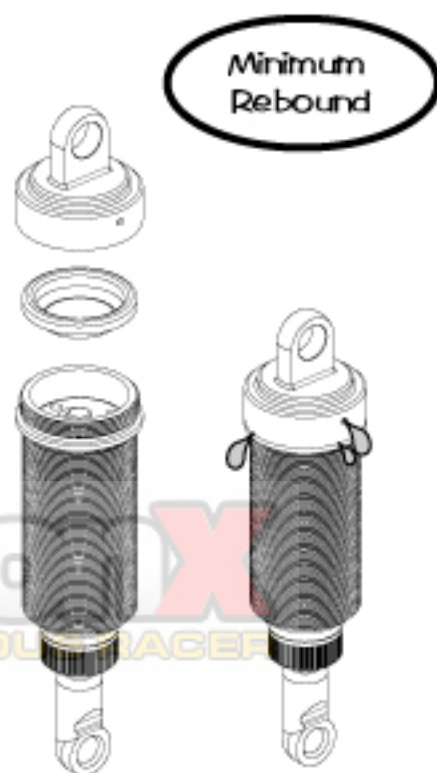
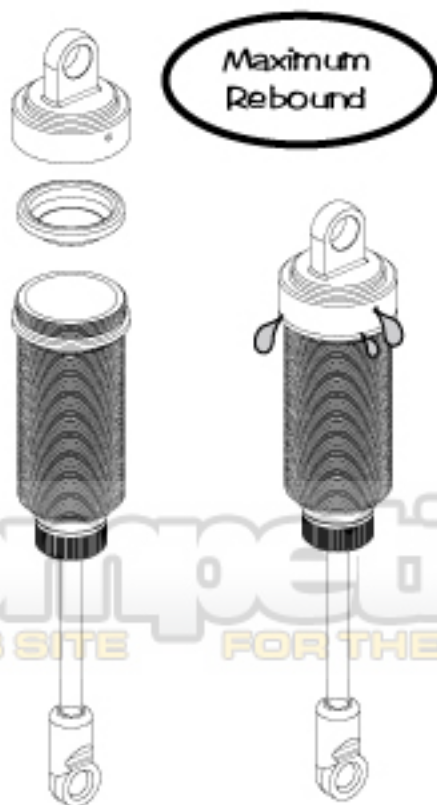
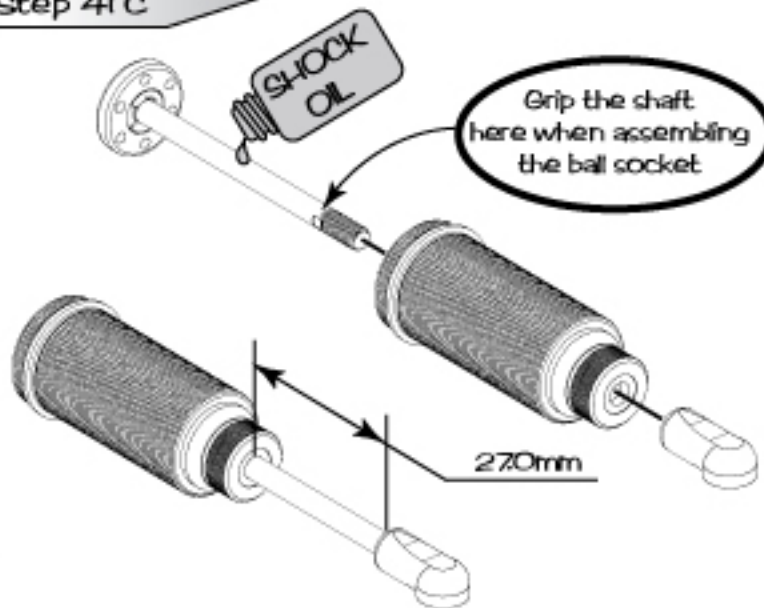

COMPETITION X  
WEB SITE FOR THE SERIOUS RACER

Step 42 C



Step 42 D

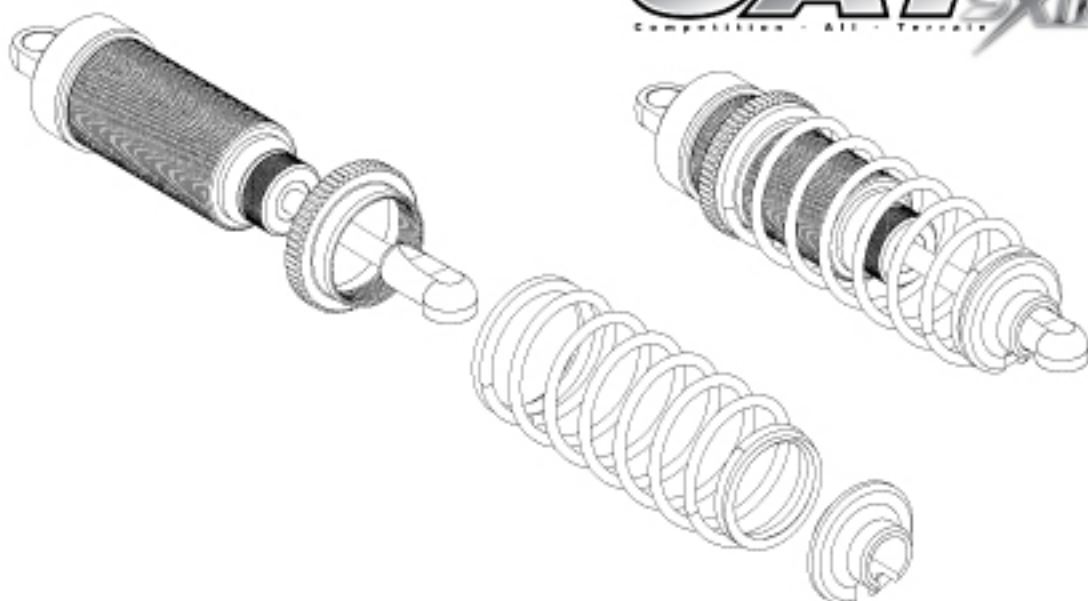

Step 43

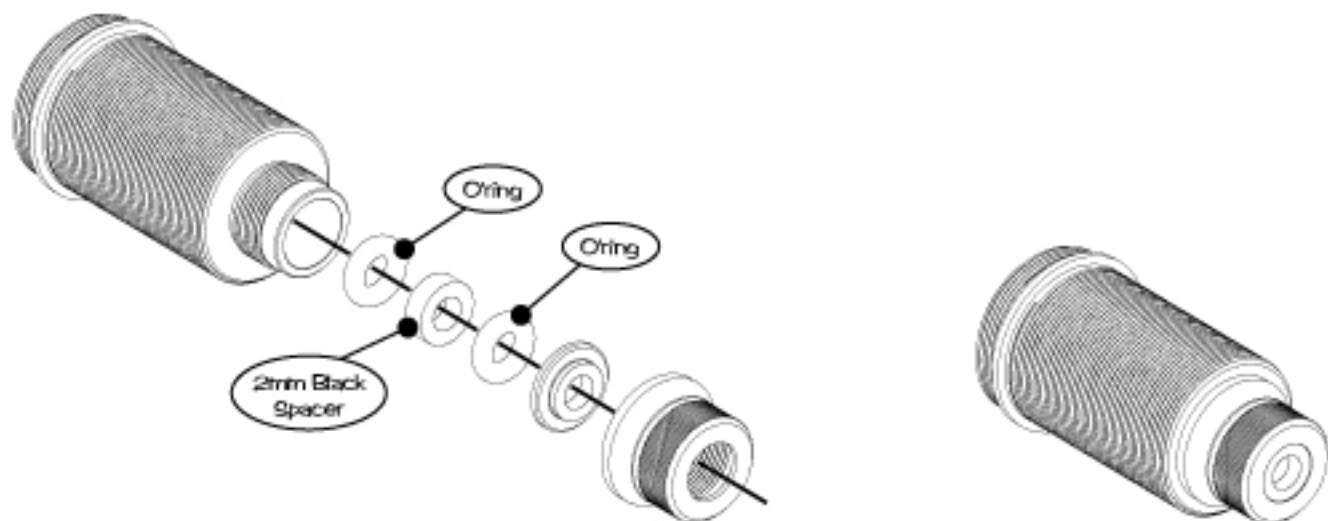

Step 44 A



Step 44 B



Step 44 C

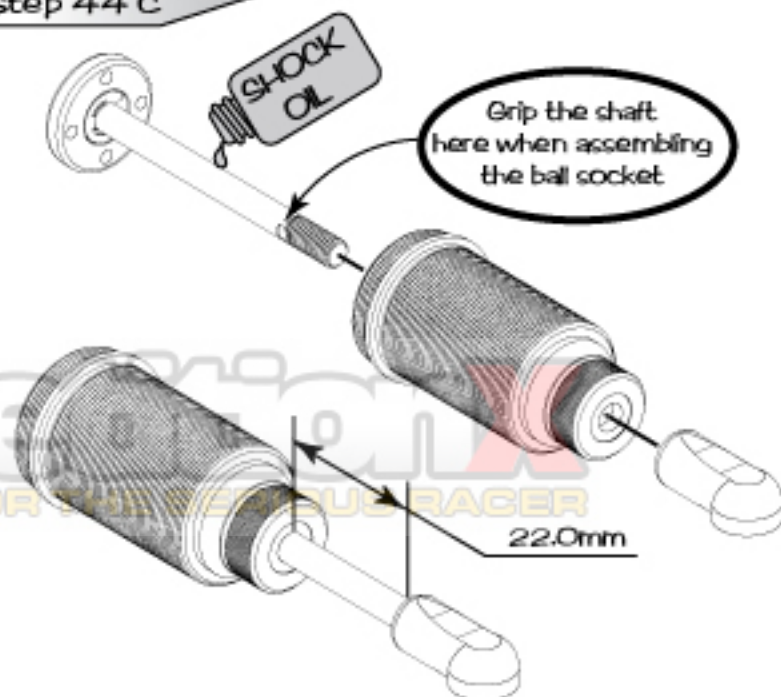



Step 45 A

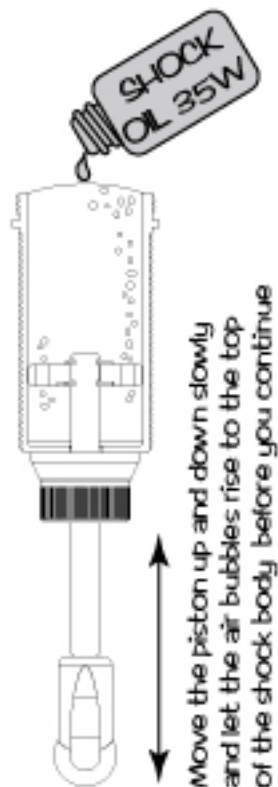

Step 45 B

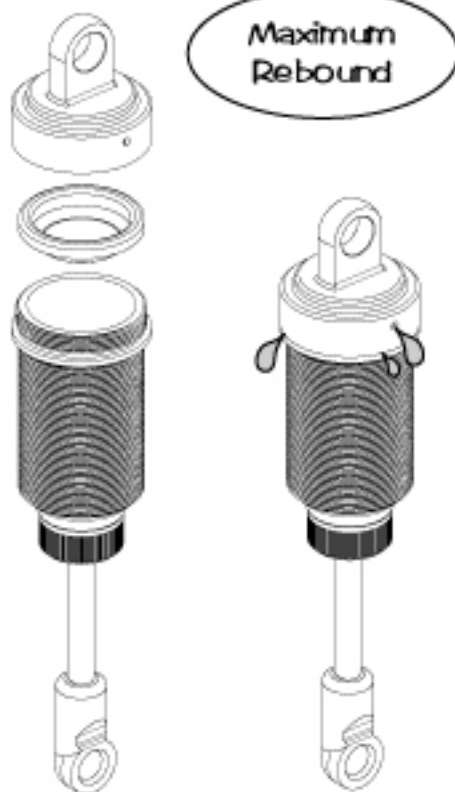

**CAT**  
COMPETITOR · ALL · TERRAIN

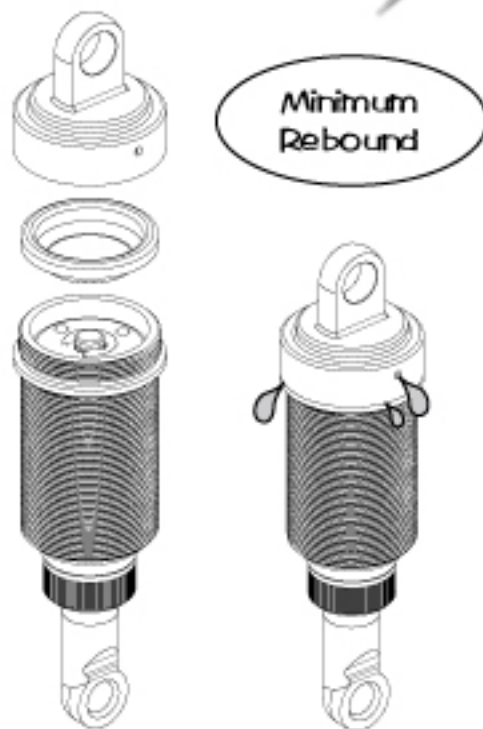

Step 45 C



Step 45 D

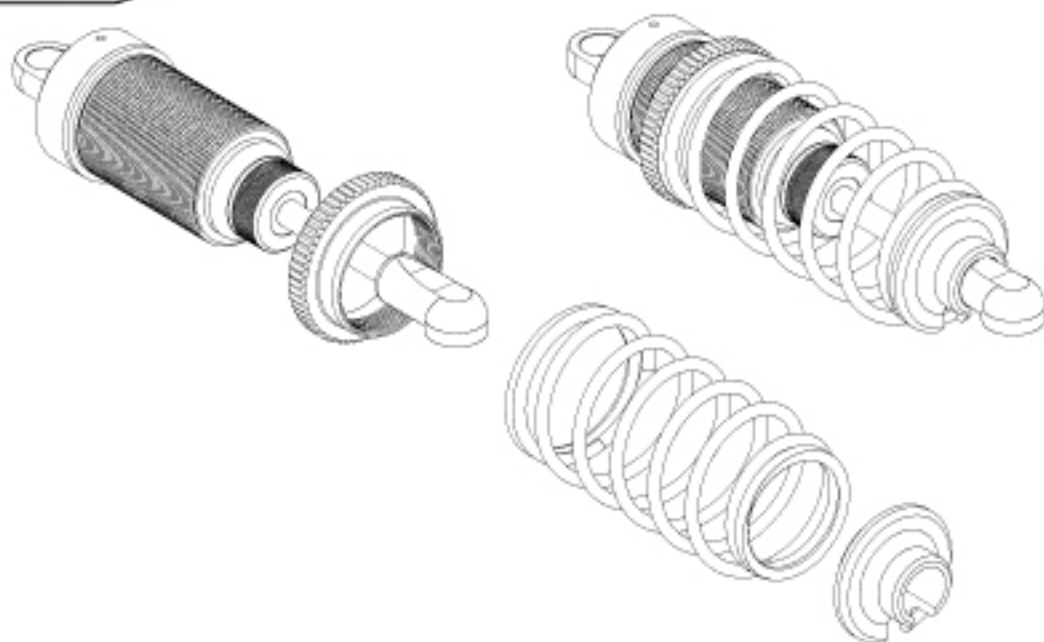

For Best Results Always Use Schumacher Silicone Oils

- G010 - Pure Silicone Shock Oil - 10w
- G015 - Pure Silicone Shock Oil - 15w
- G020 - Pure Silicone Shock Oil - 20w
- G025 - Pure Silicone Shock Oil - 25w
- G030 - Pure Silicone Shock Oil - 30w
- G035 - Pure Silicone Shock Oil - 35w
- G040 - Pure Silicone Shock Oil - 40w
- G045 - Pure Silicone Shock Oil - 45w
- G050 - Pure Silicone Shock Oil - 50w



Step 46 A

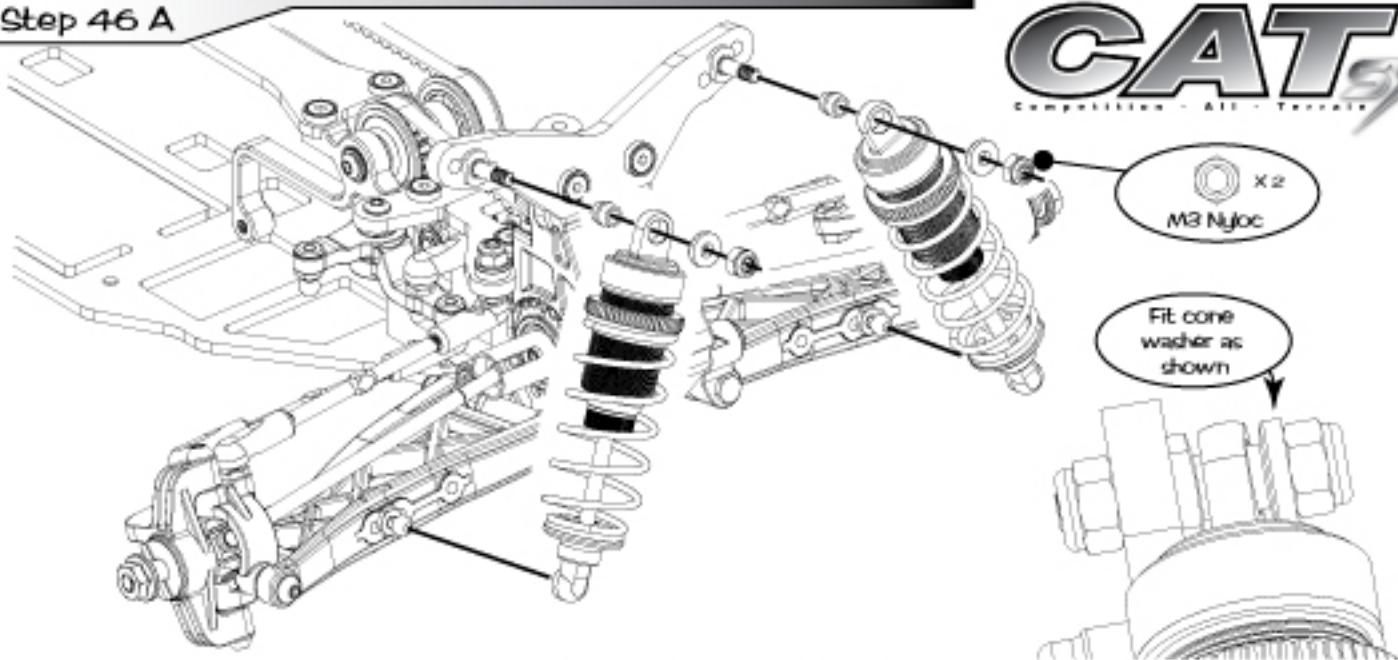

Step 46 B

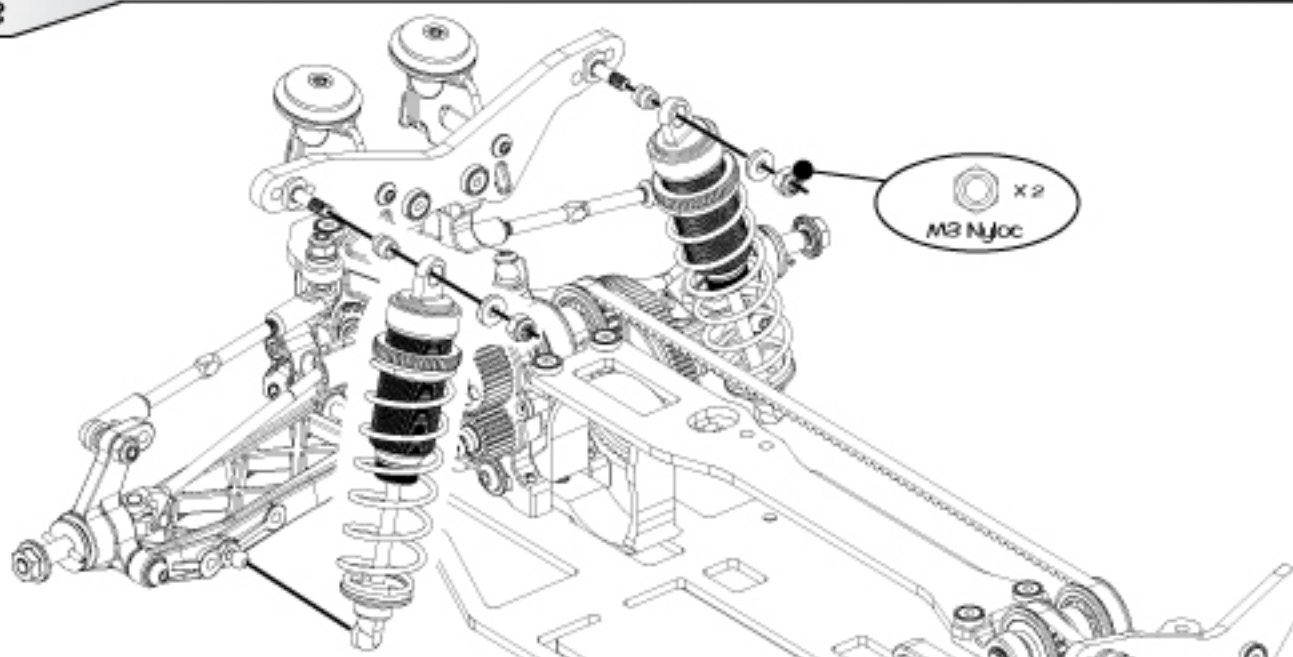

Step 46

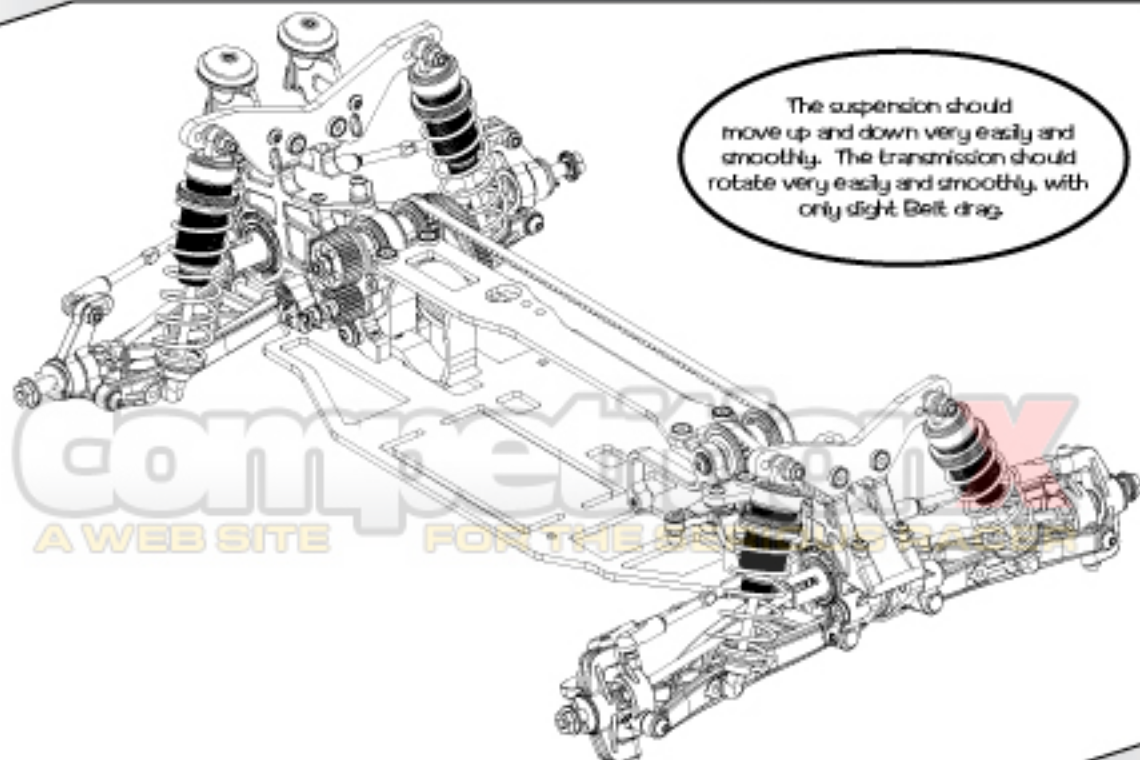



Step 47

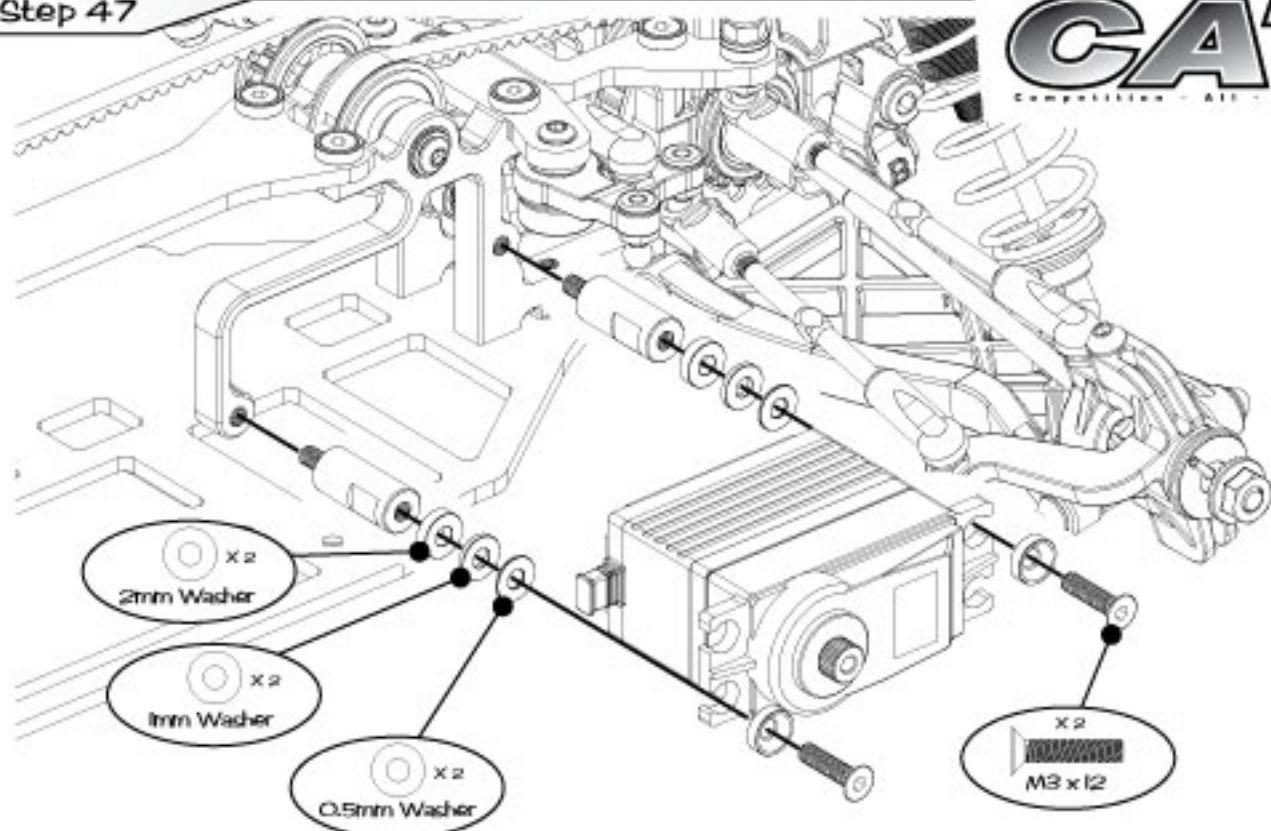

Step 48 A

Choose the correct Servo Horn

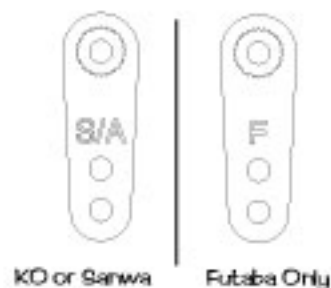
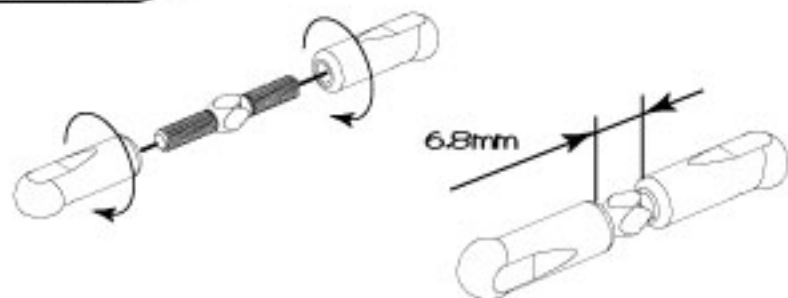

Step 48 B

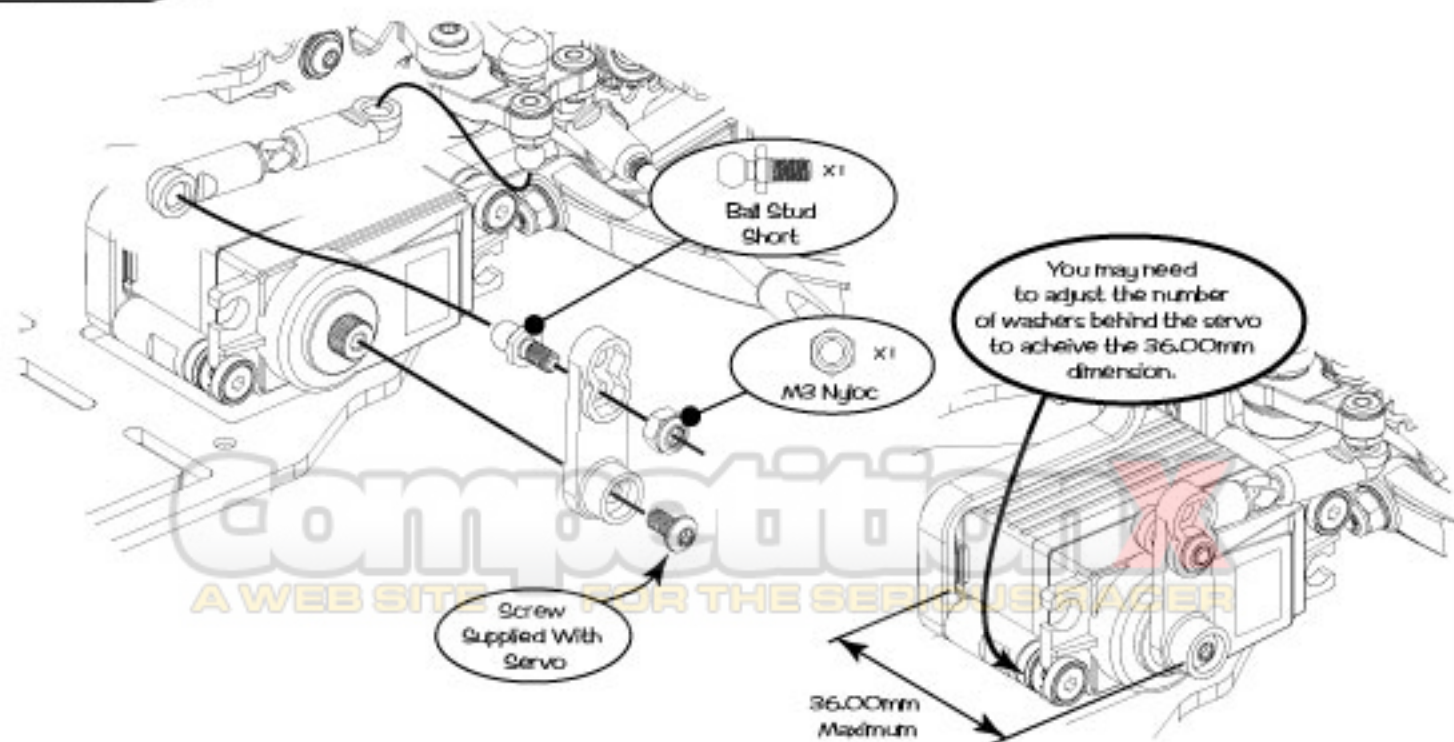

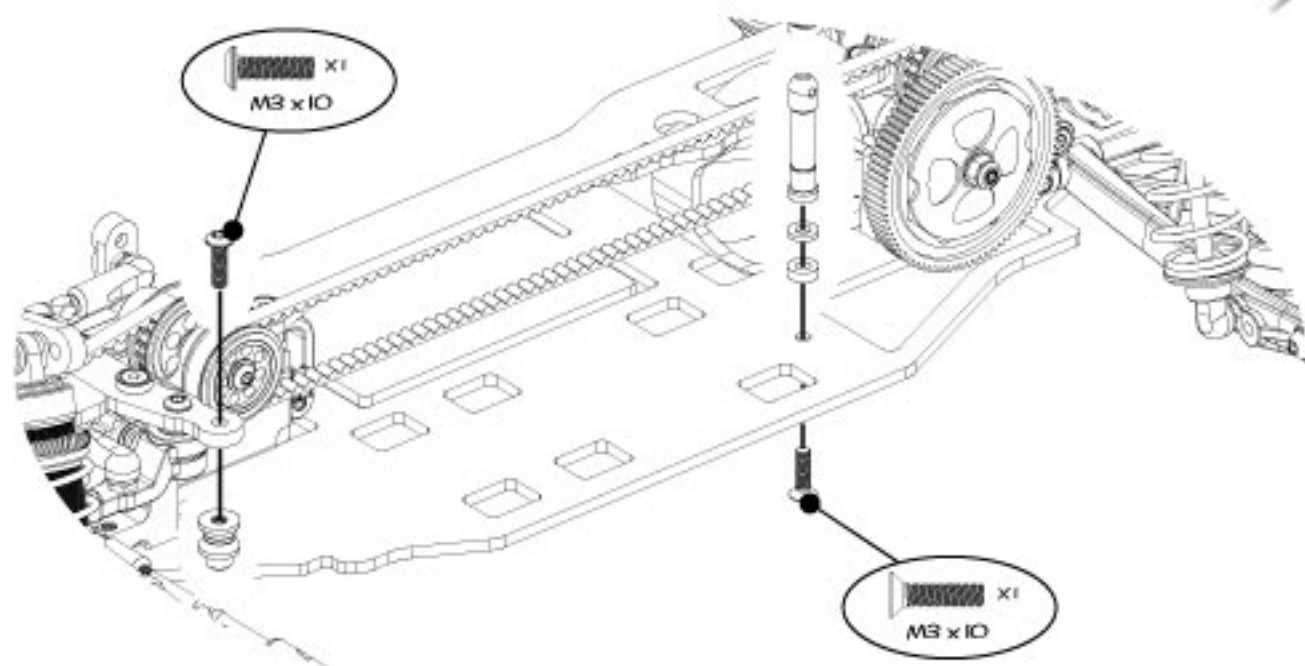

## Step 49 B (Li-Po Installation for Batteries with Humps)

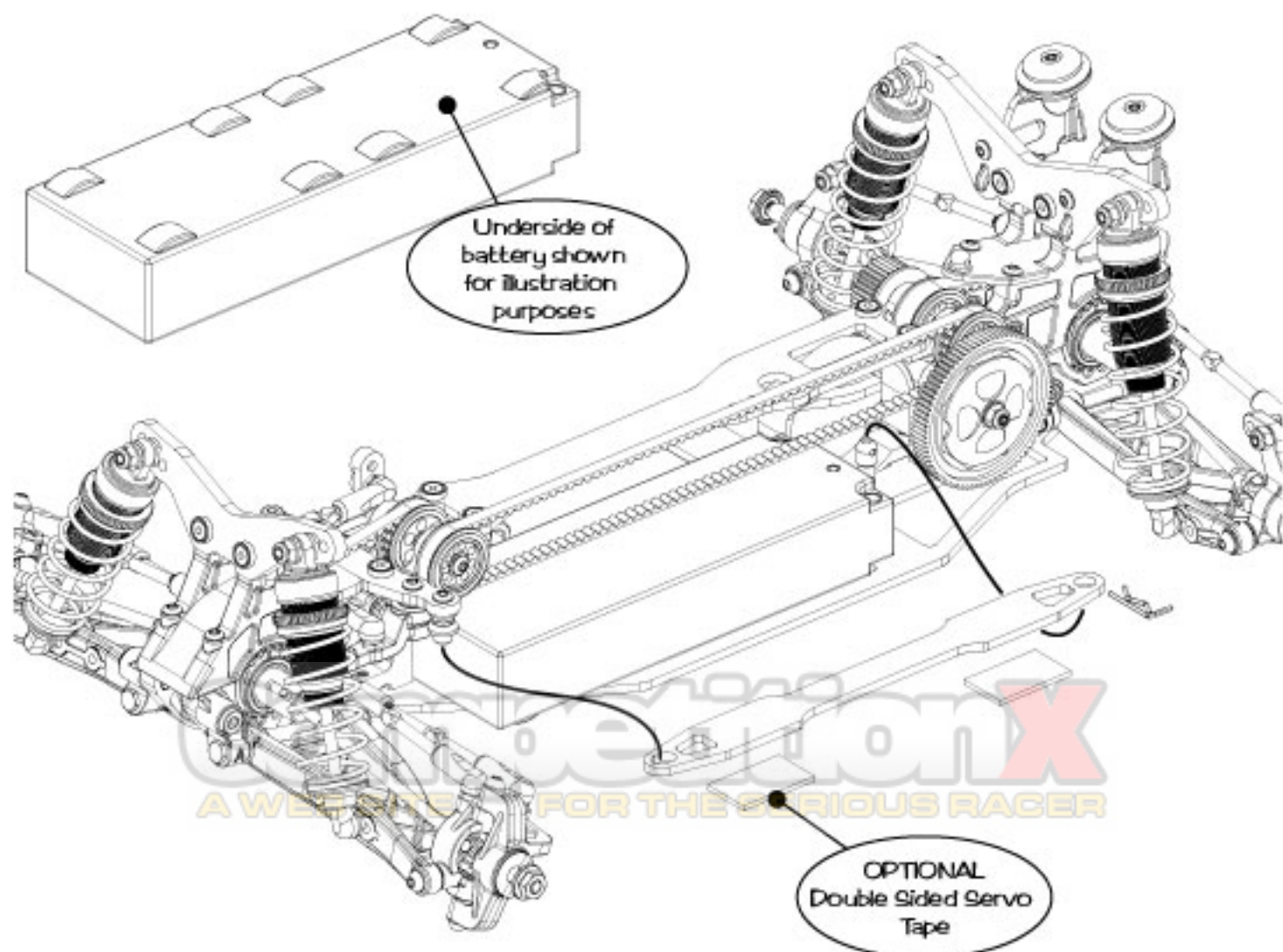



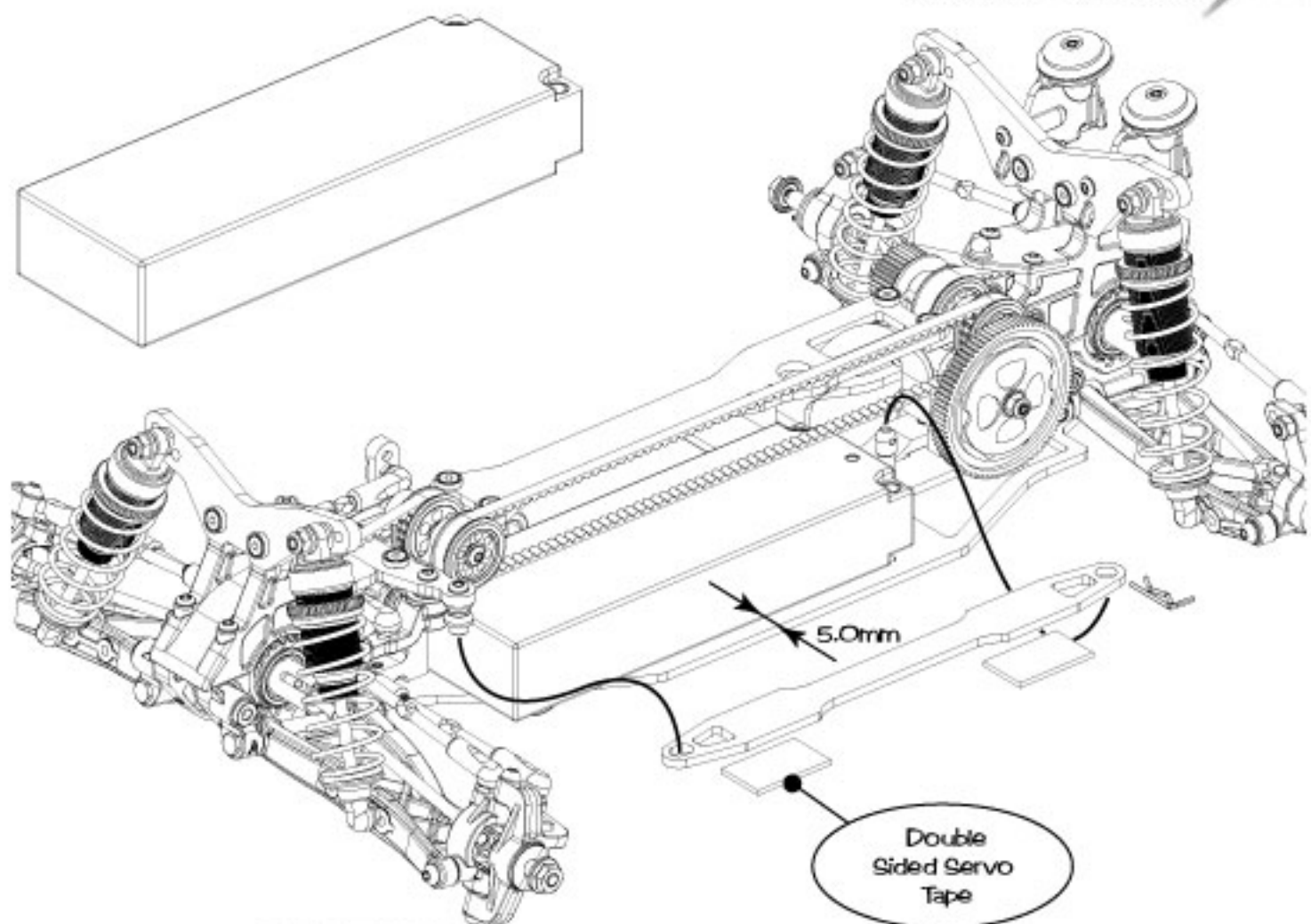

Place the Flat bottomed Li-Po as far forward as possible, touching the front transmission housing, align the edge of the battery with the left side of the chassis leaving a 5.0mm gap. Using Double sided tape fix the Li-po Strap in the car and stick it to the Li-Po Battery. Turn the car over and superglue U3569 Li-Po Locators to the bottom of your Battery.

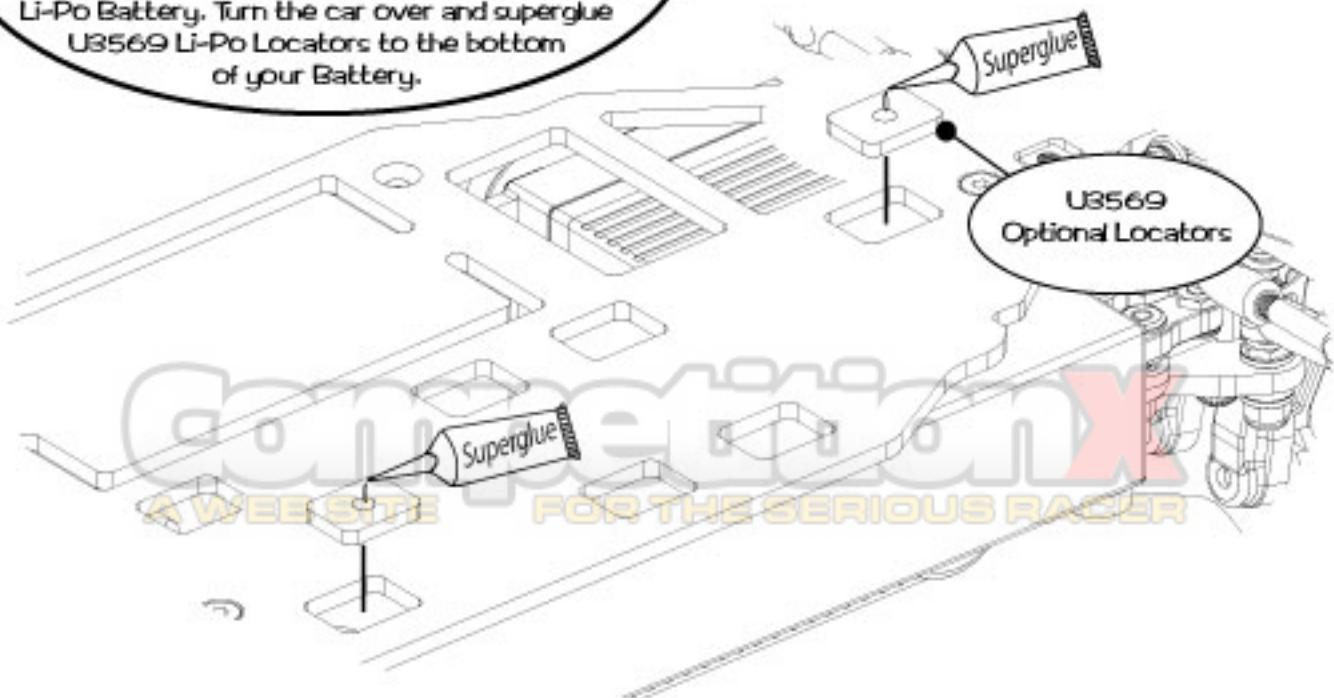

CompetitionX  
A WEB SITE FOR THE SERIOUS RACER

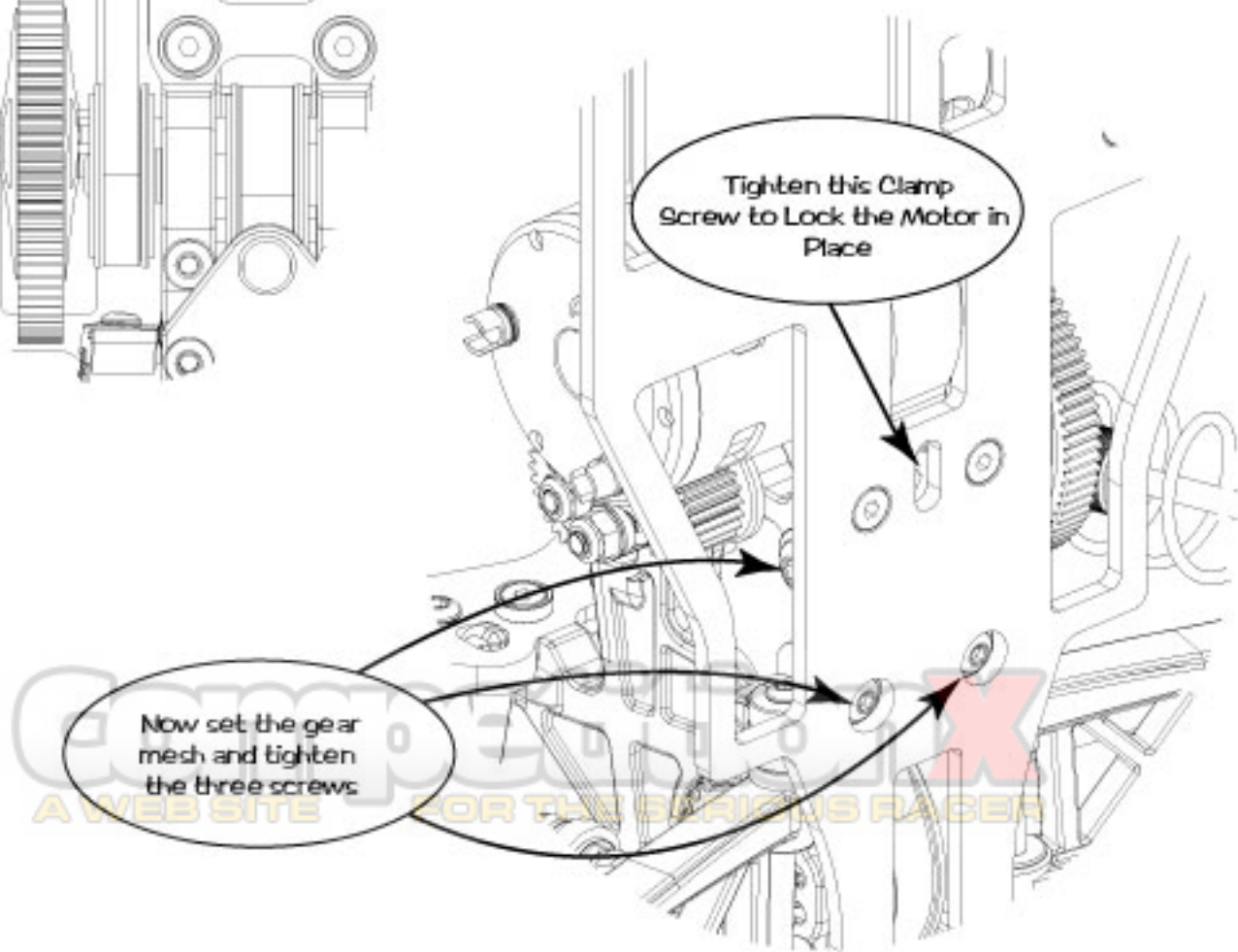
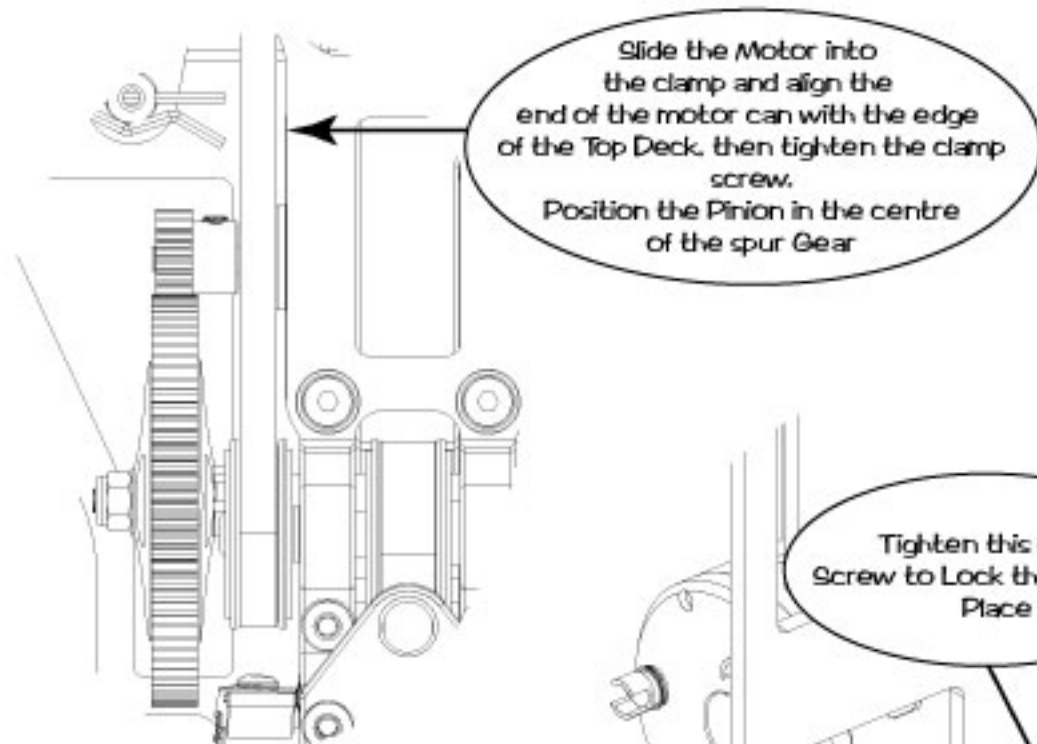
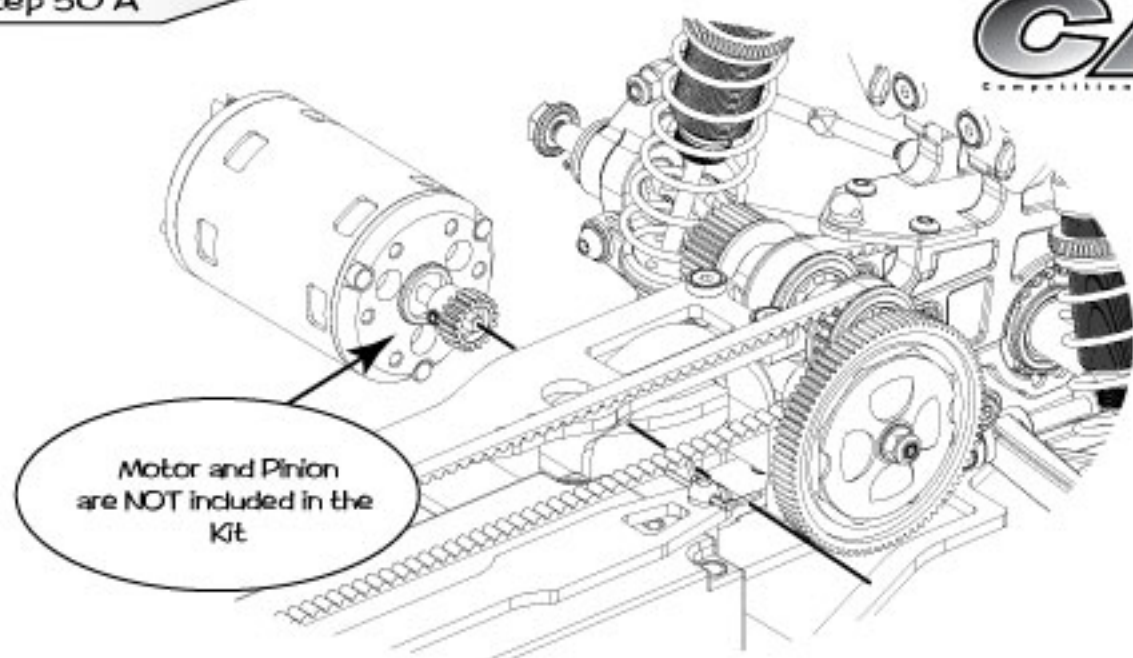



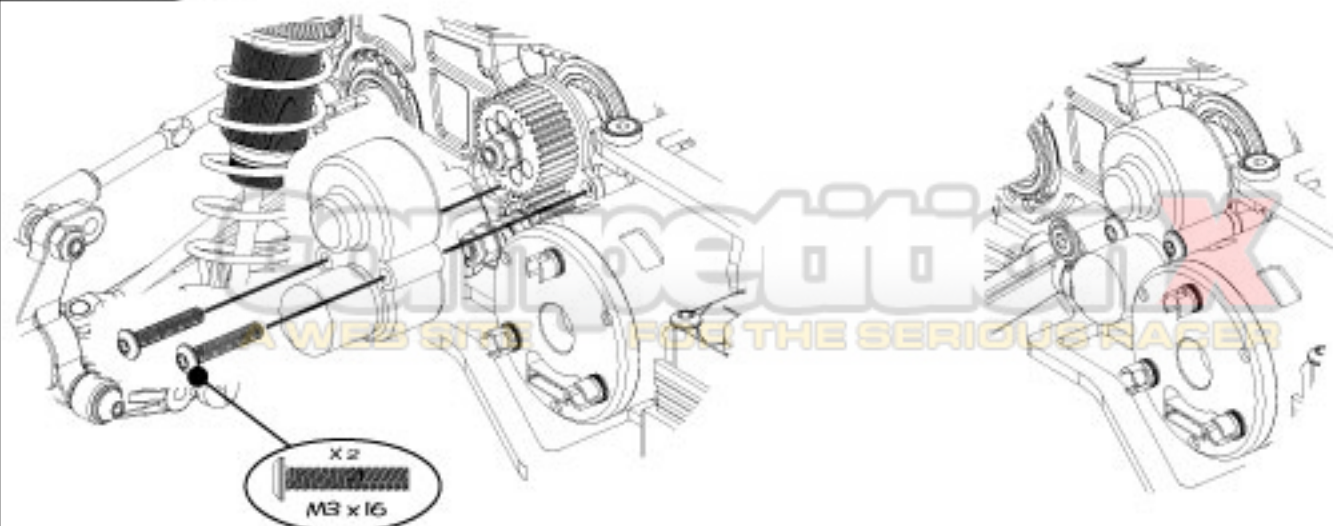
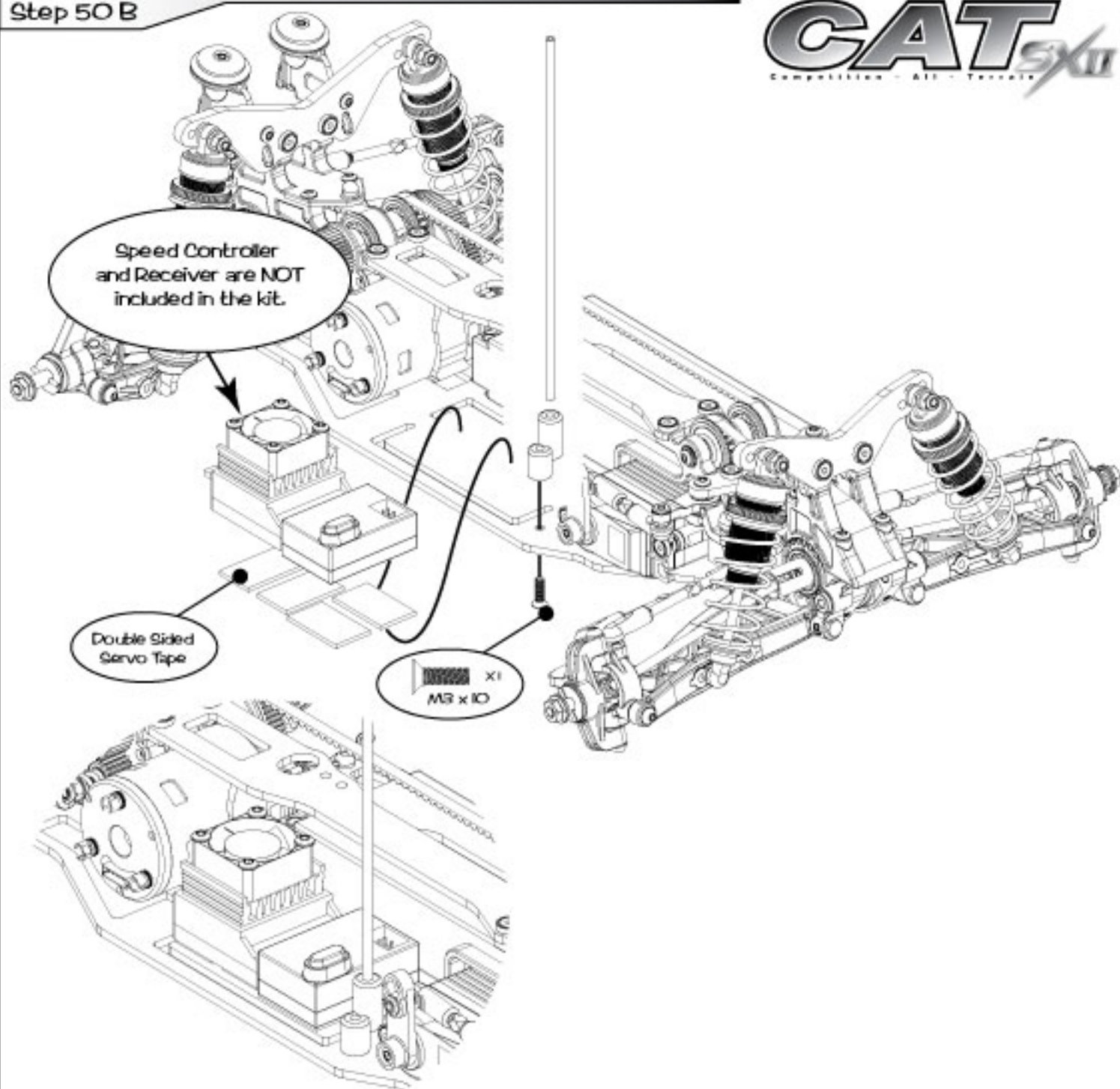



### Step 5I B

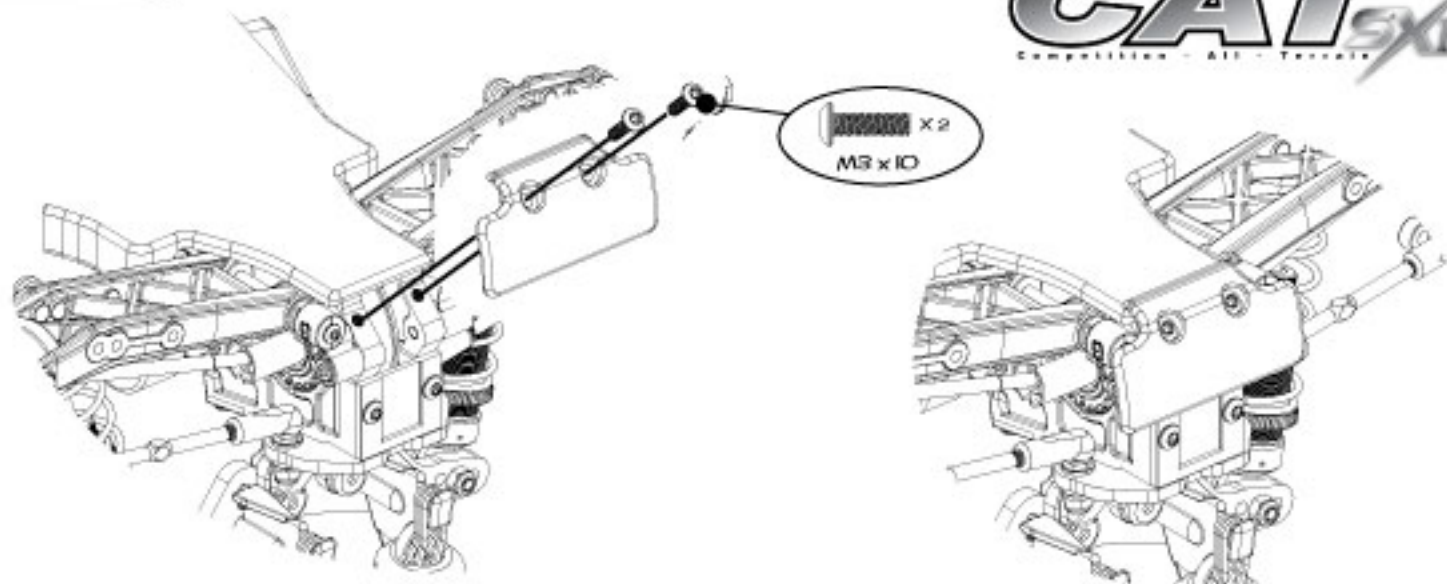

### Step 5I C



Drill or Ream 3.0mm holes in the undertray to line up with the 2 holes in the transmission housings



After Drilling the holes in the undertray ensure that the front edge is no more than 9.0mm from the new holes

### Step 5I D

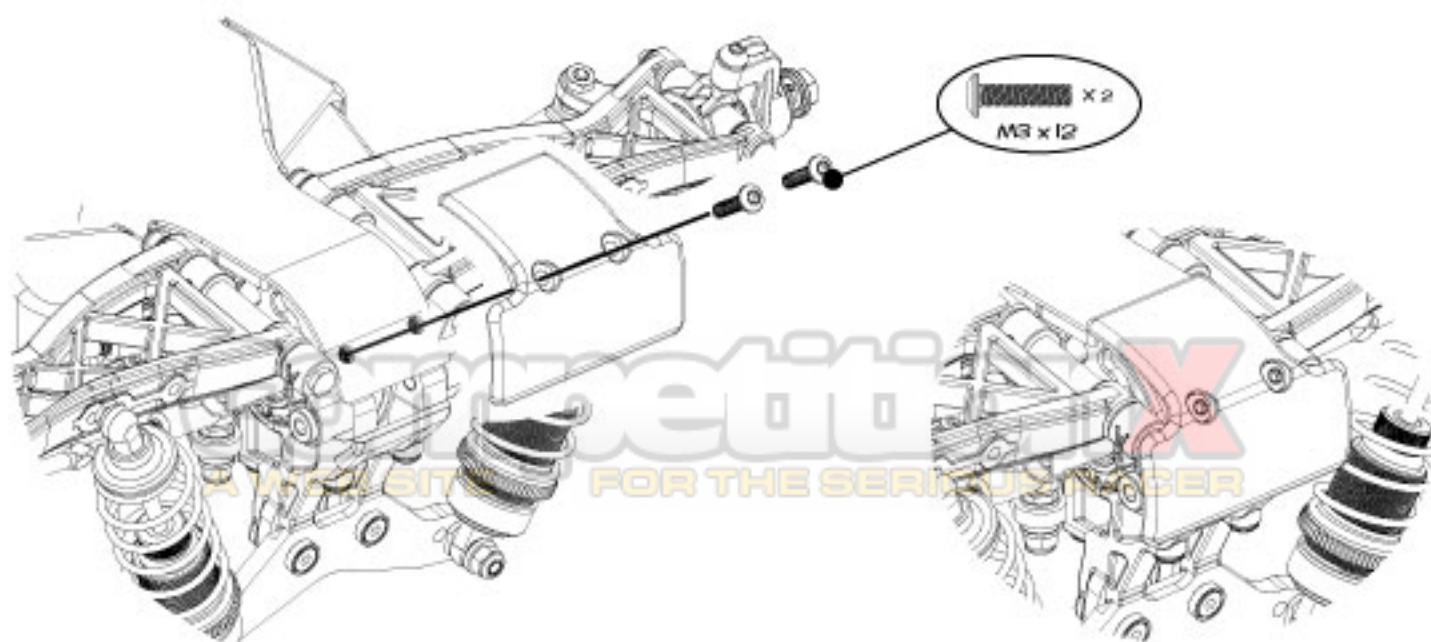

Step 52

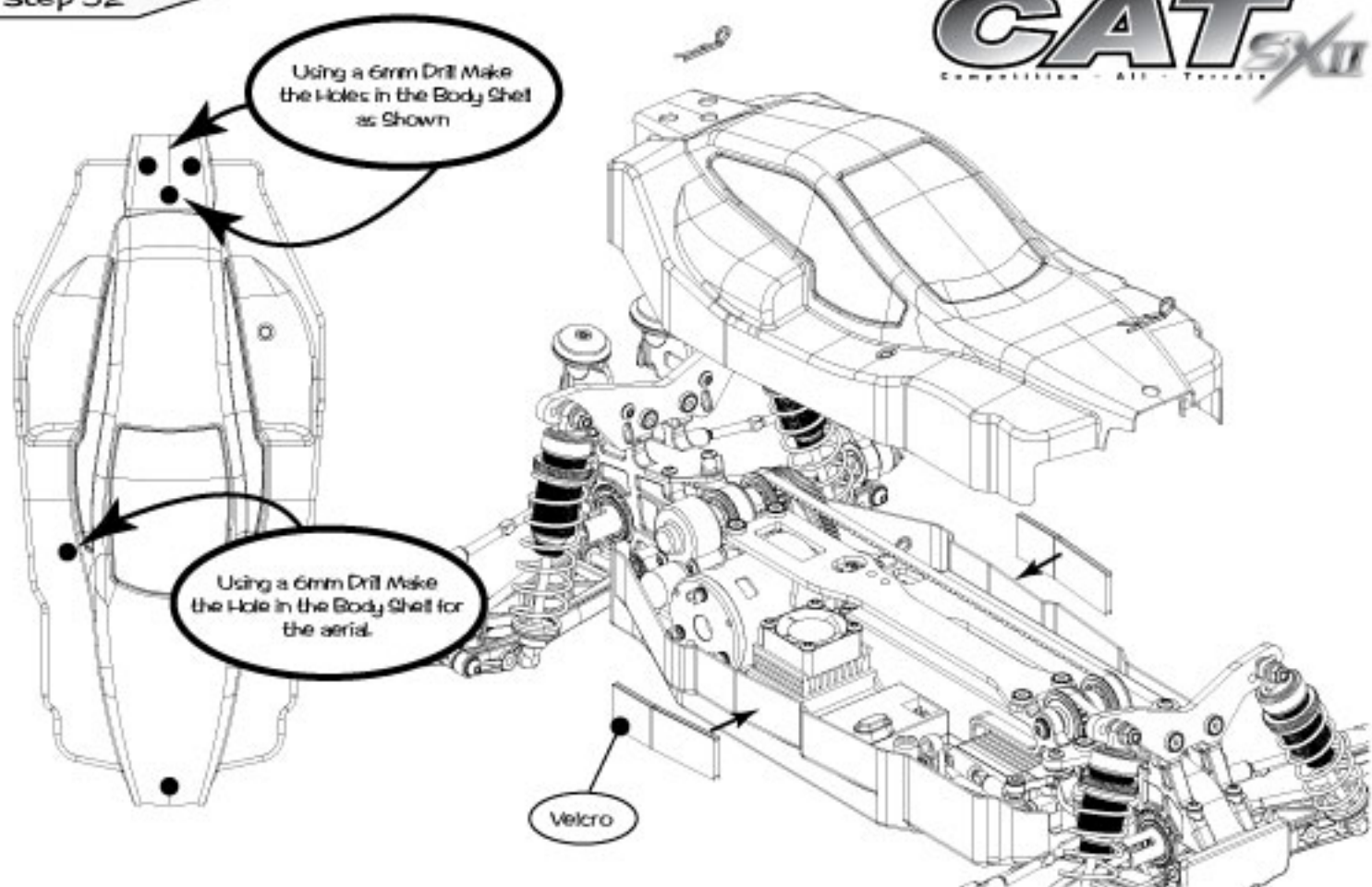

Step 53 A

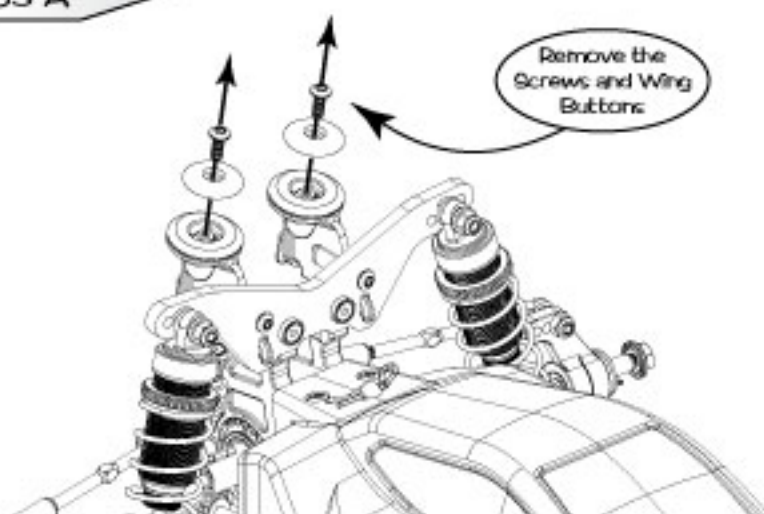

Step 53 B

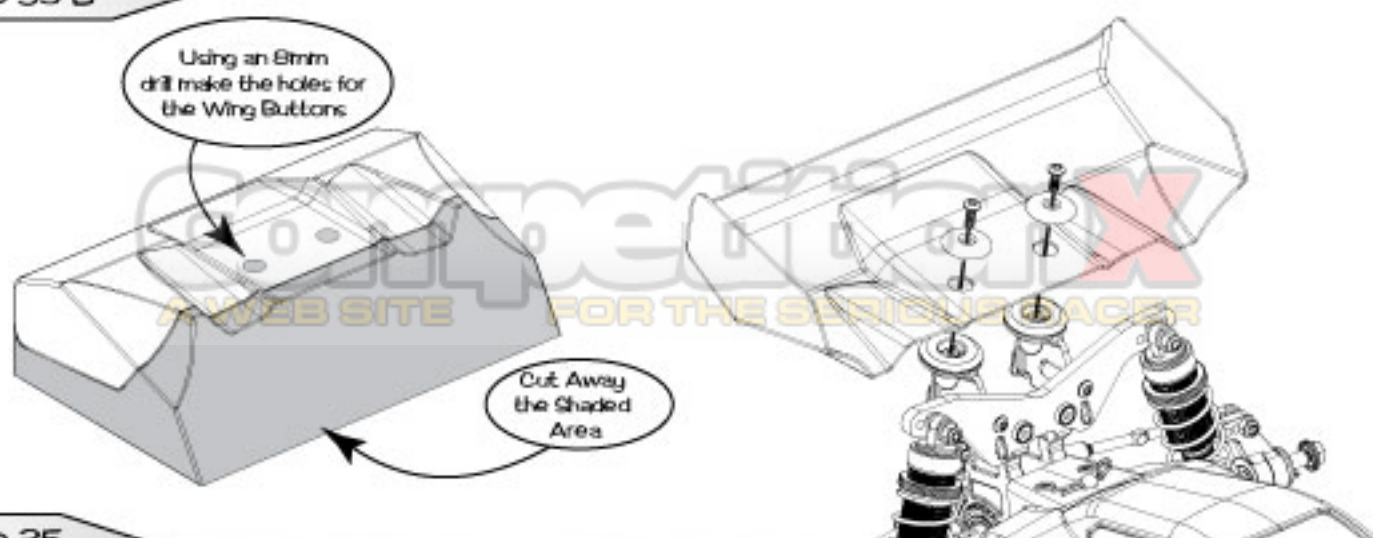



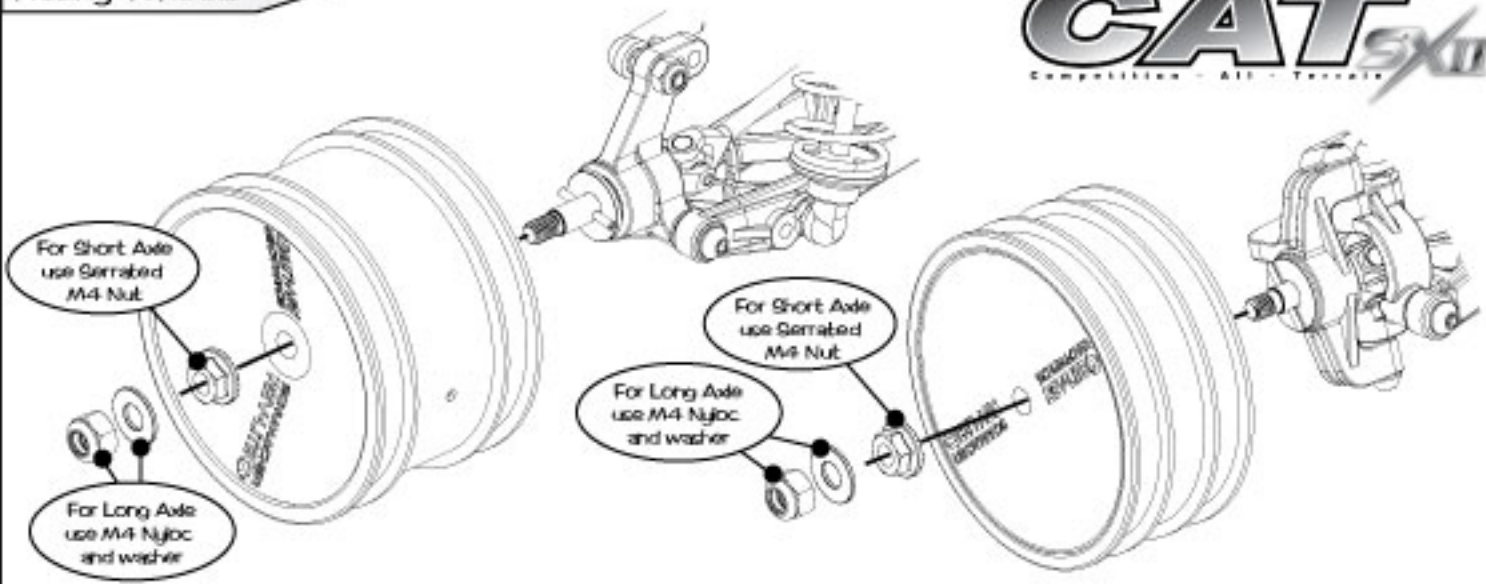

Optional Front Wheel Fixing for other Manufacturers Wheels

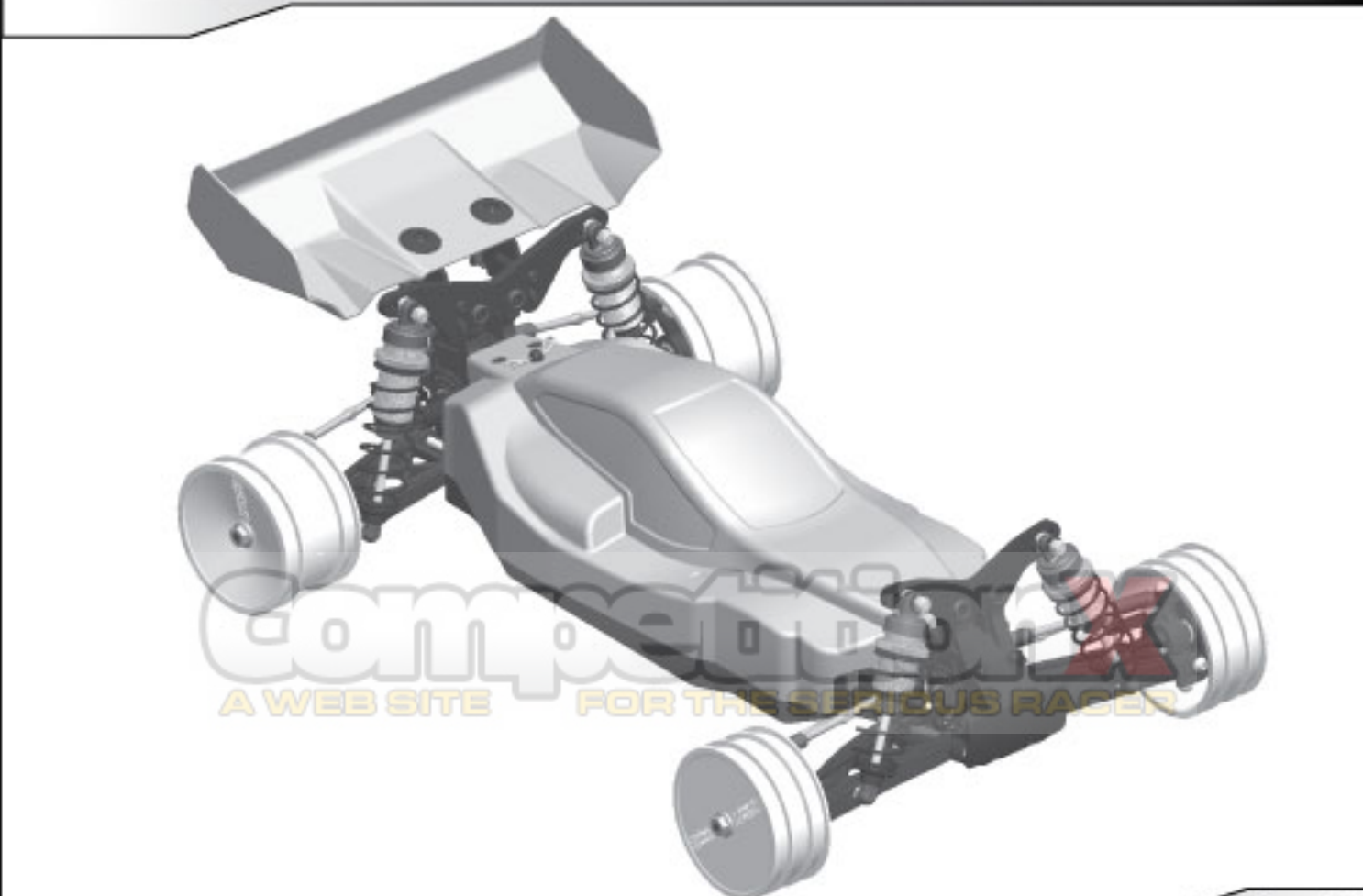
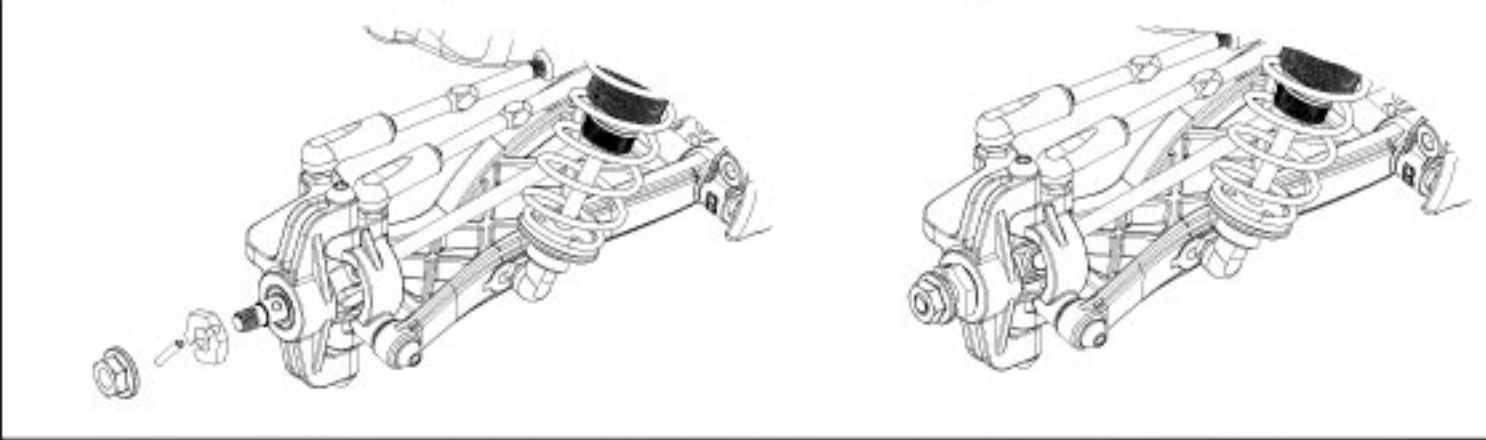

COMPETITION  
 A WEB SITE FOR THE SERIOUS RACER



### U3379 Front Roll Bar Option

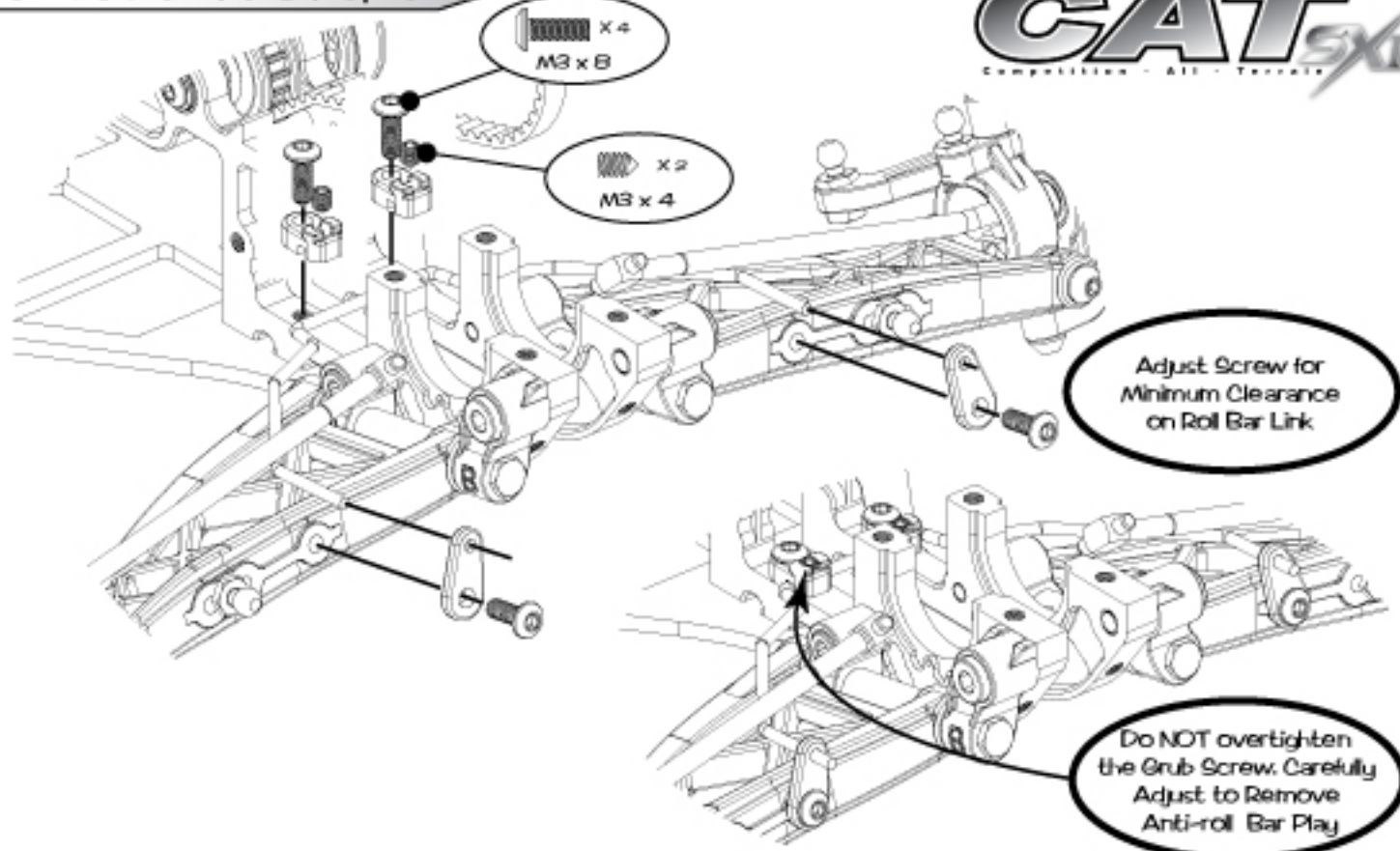

### U3380 Rear Roll Bar Option (A)

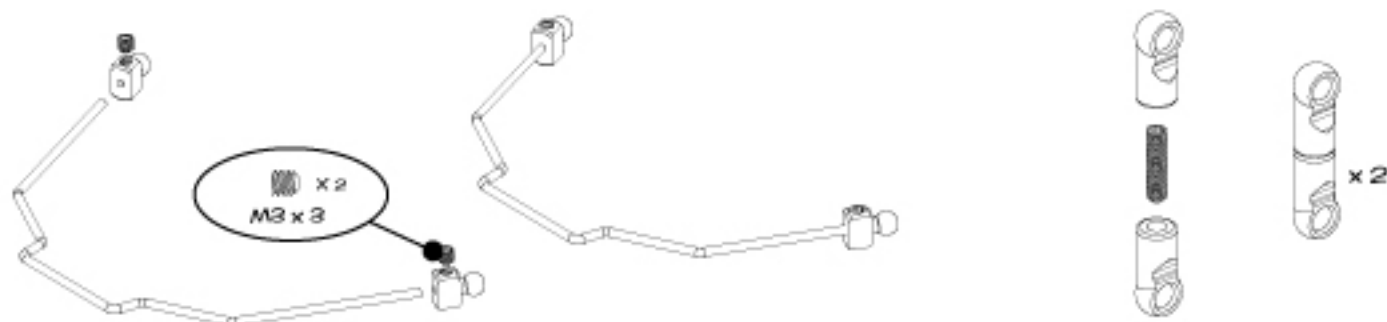

### U3380 Rear Roll Bar Option (B)

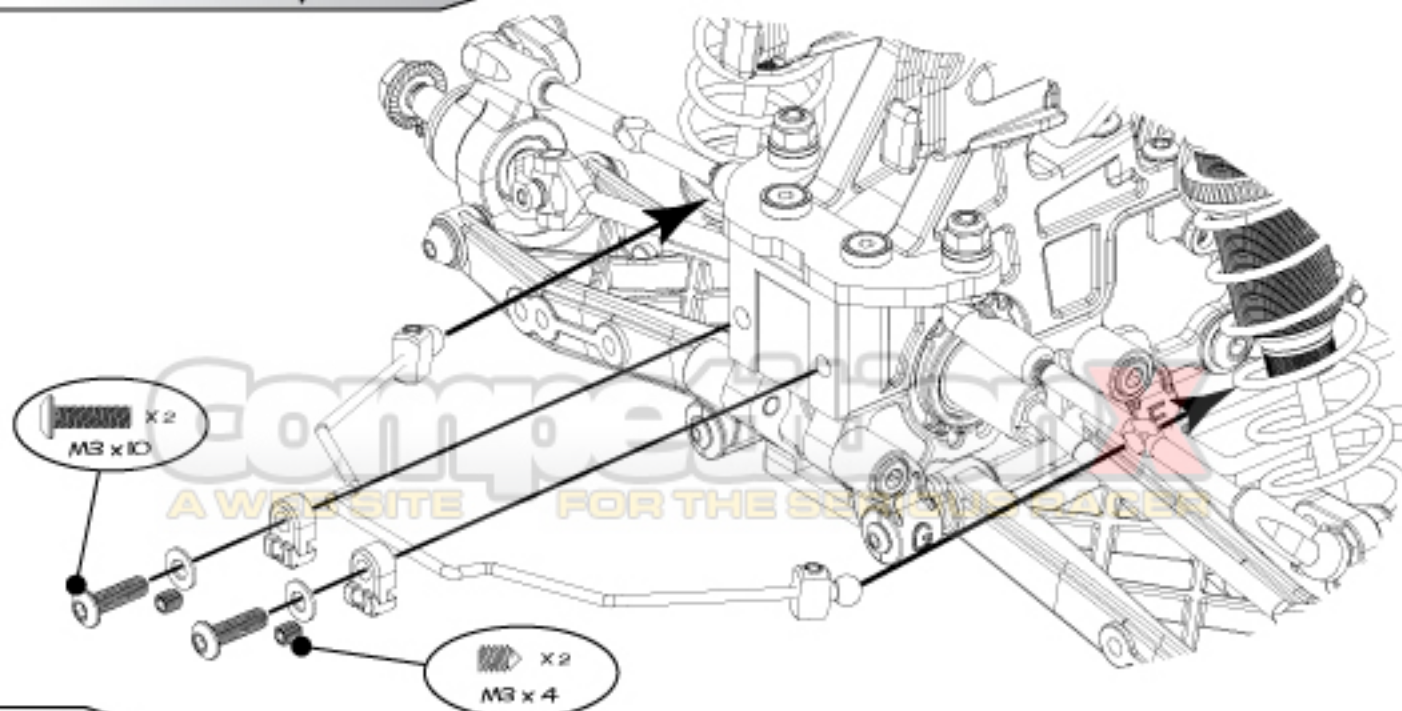

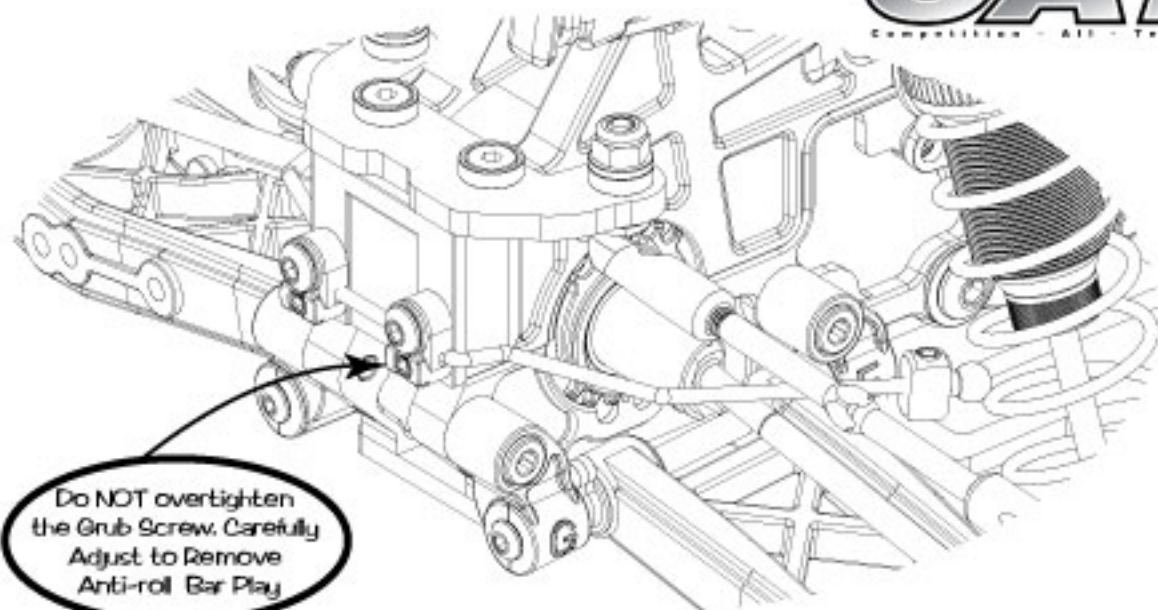

Do NOT overtighten the Grub Screw. Carefully Adjust to Remove Anti-roll Bar Play

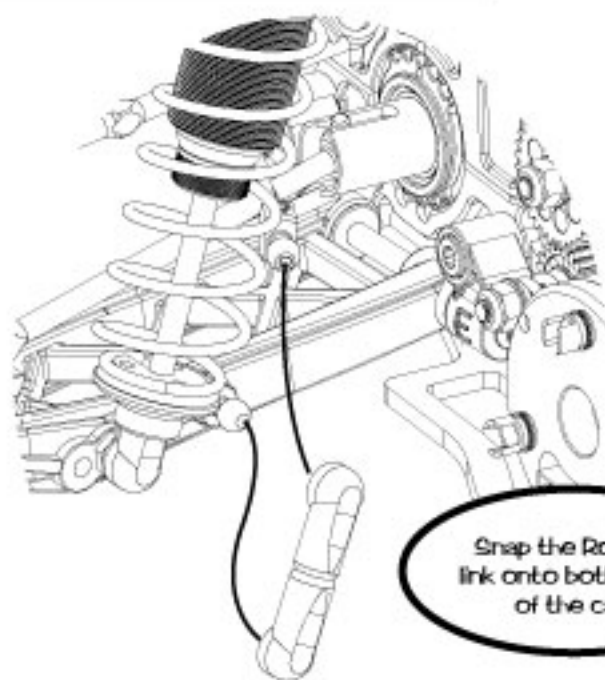

Snap the Roll Bar link onto both sides of the car

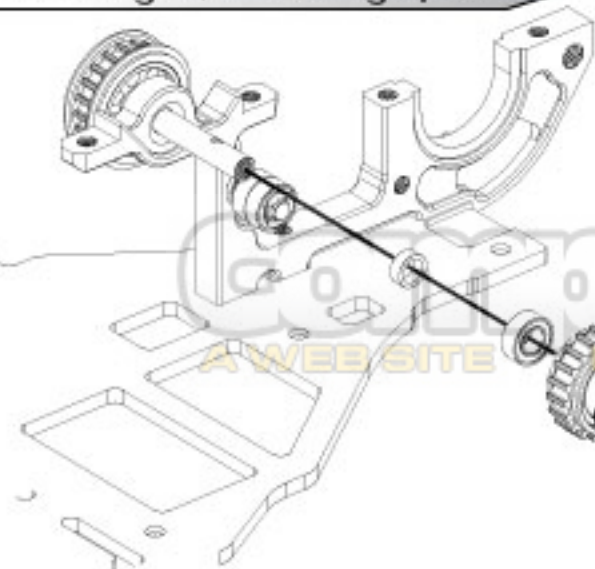
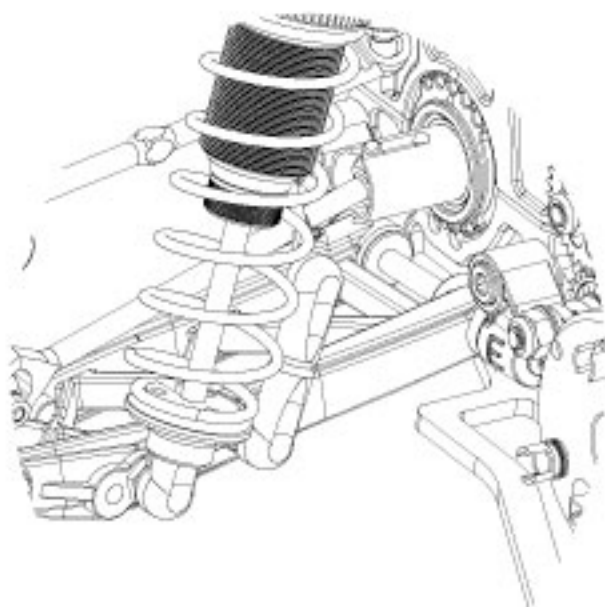

Only Fit the Pin if you want to lock out the One Way

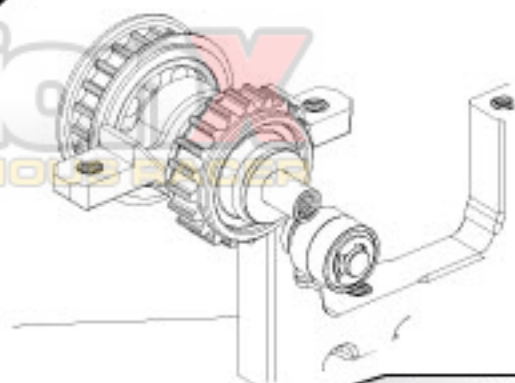



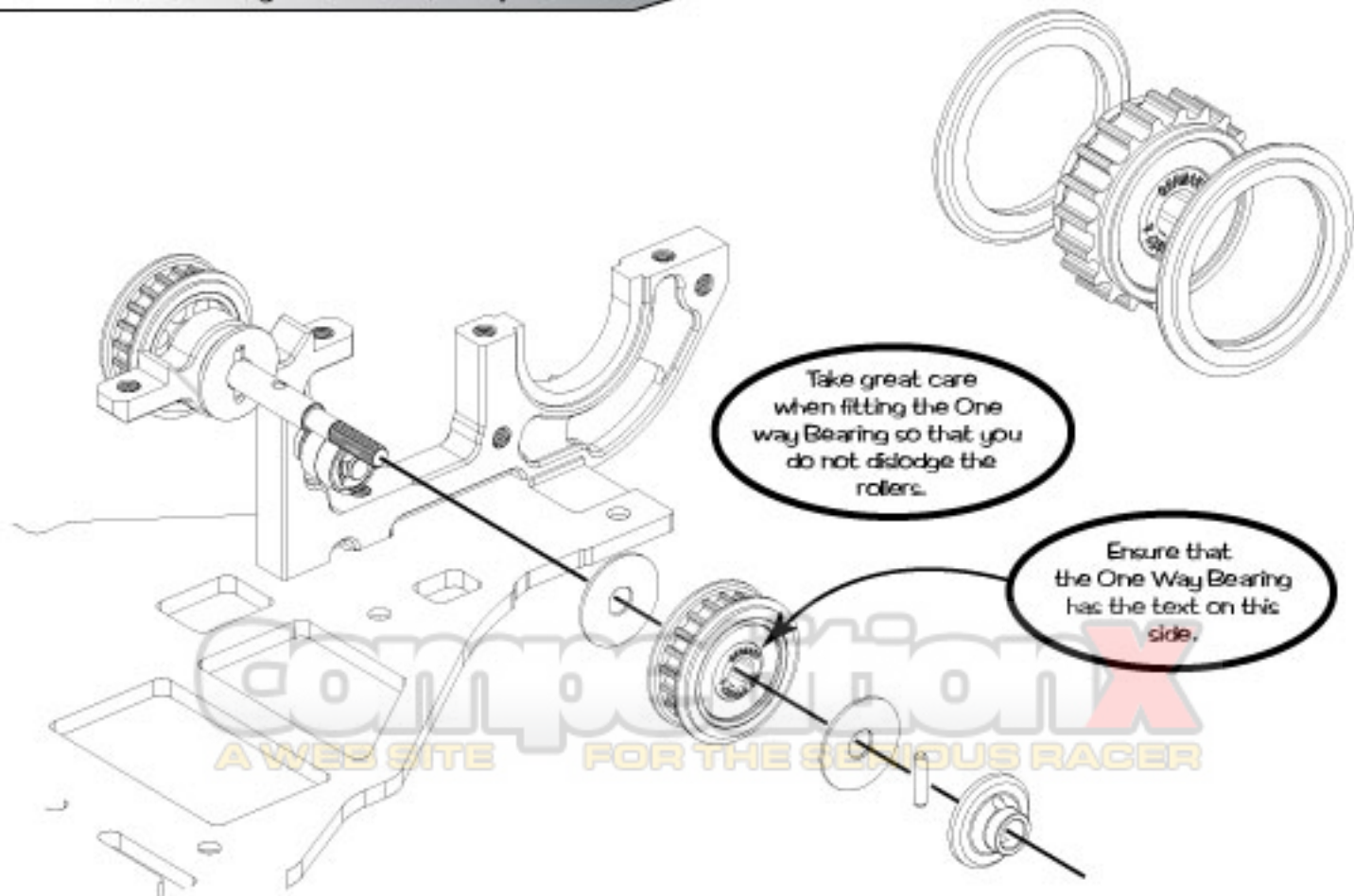
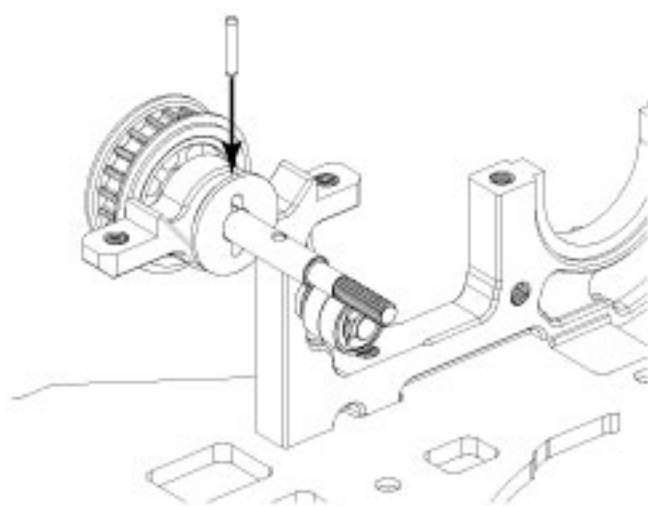
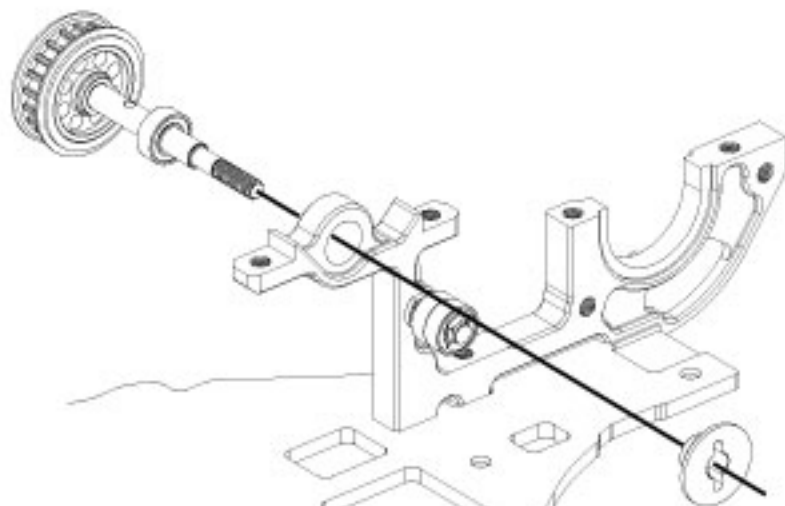



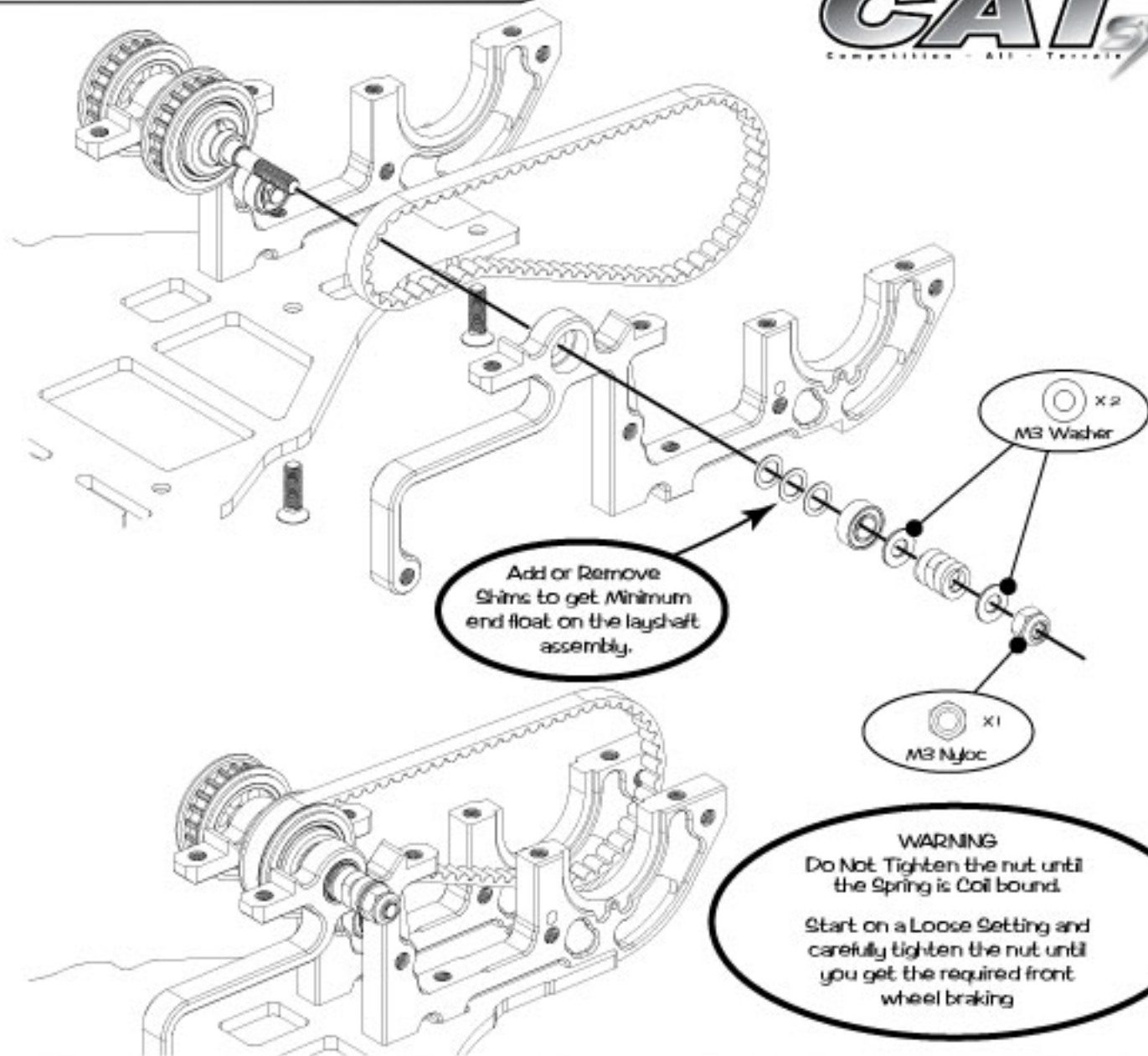

U3372 Front One Way Option

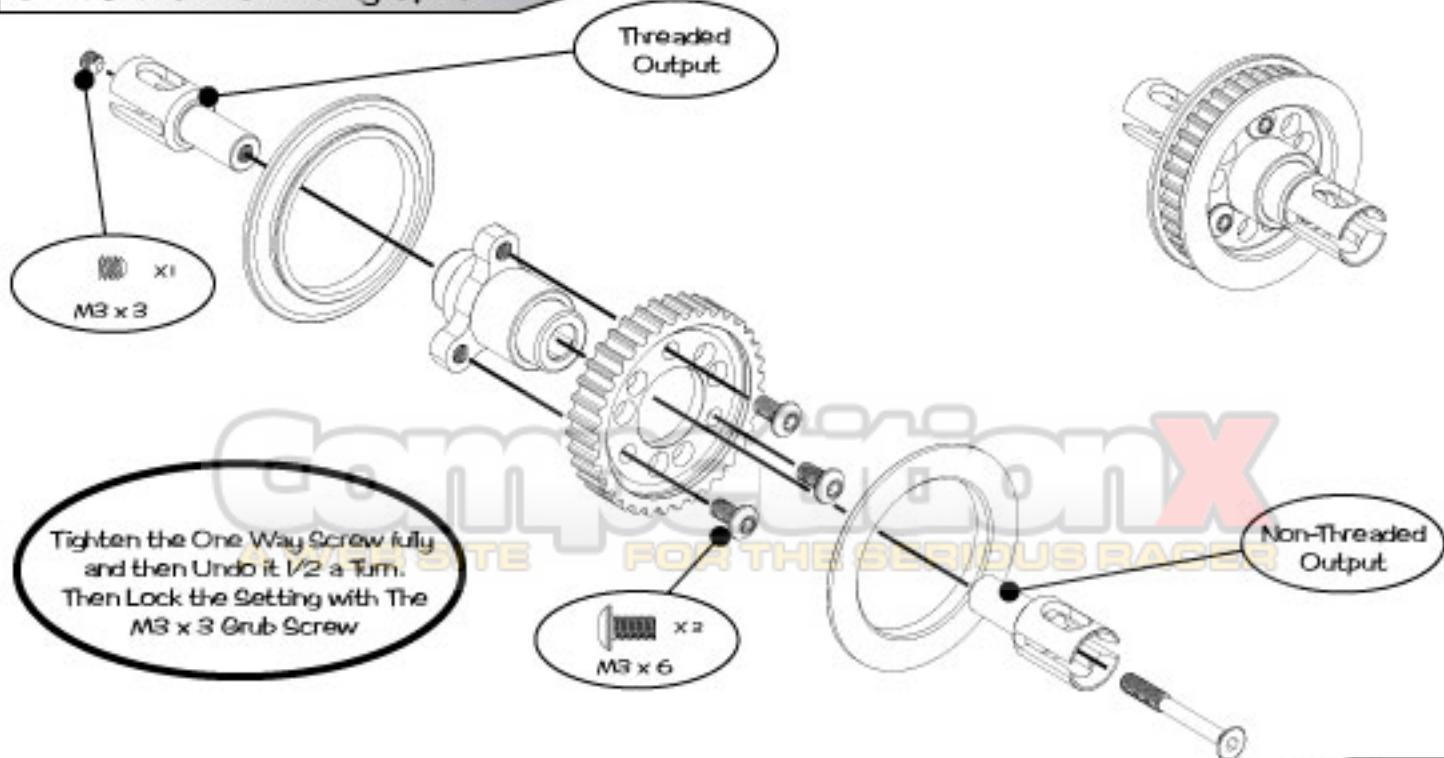

U3768 Alloy Steering Conversion Option (A)

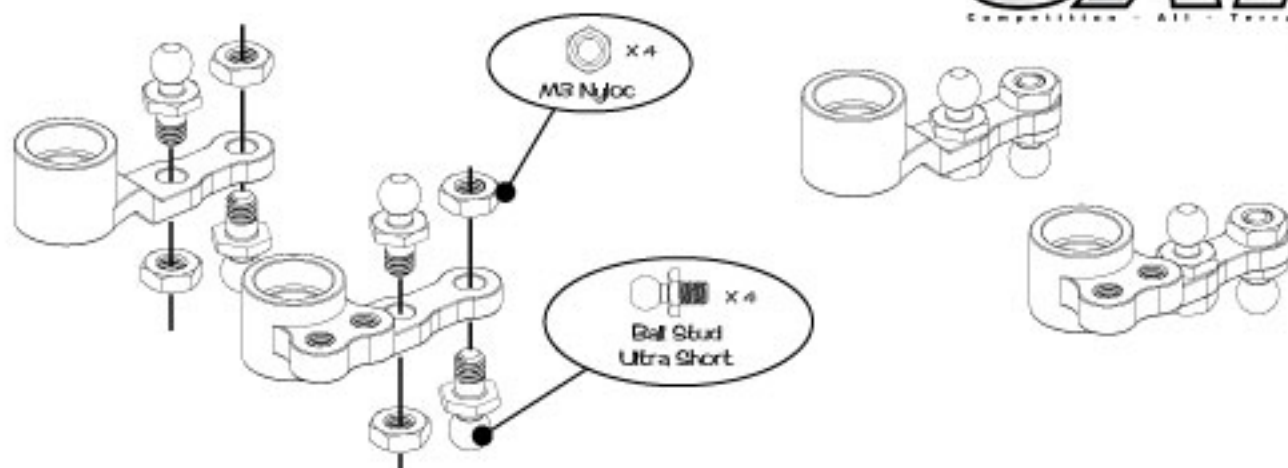

U3768 Alloy Steering Conversion Option (B)

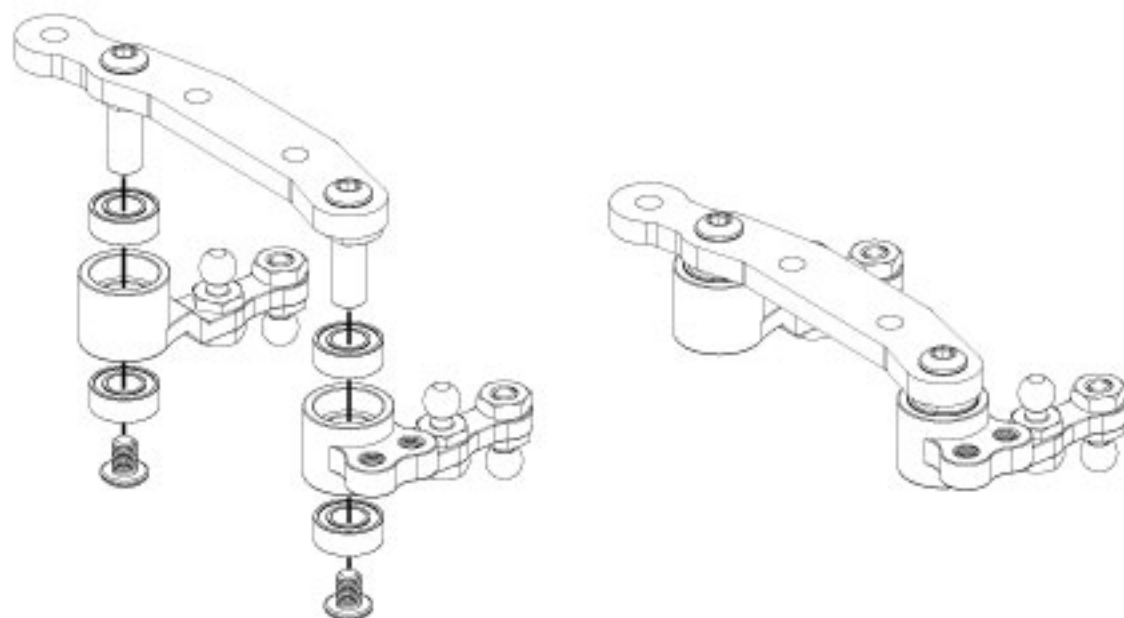

U3768 Alloy Steering Conversion Option (C)

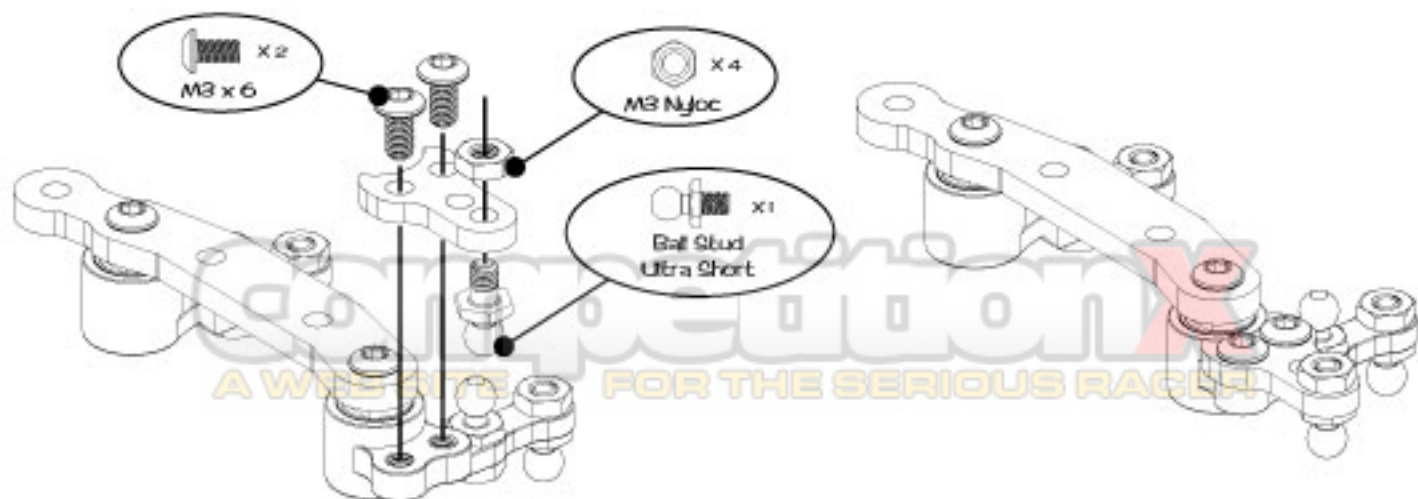

U3304-U3556-U3603 Alloy Pivot Blocks Option (A)

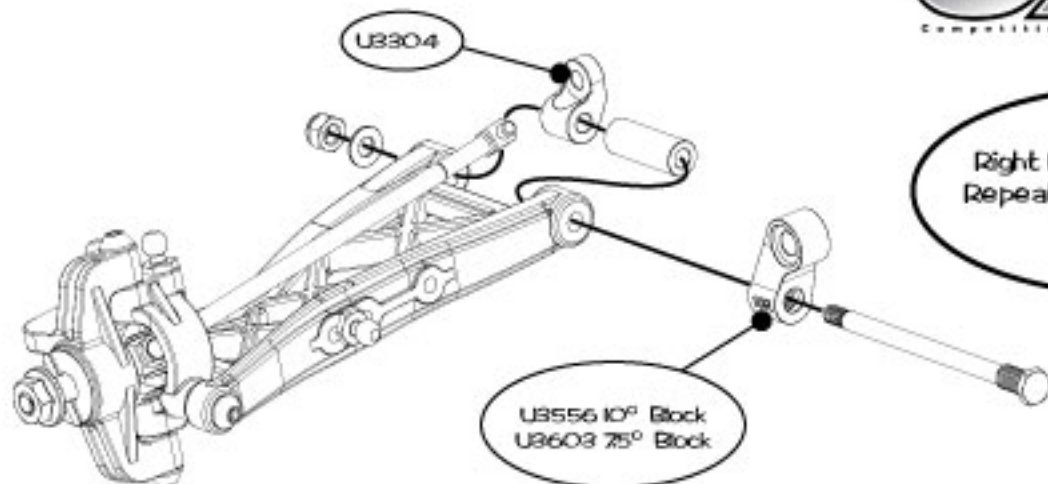

U3304-U3556-U3603 Alloy Pivot Blocks Option (B)

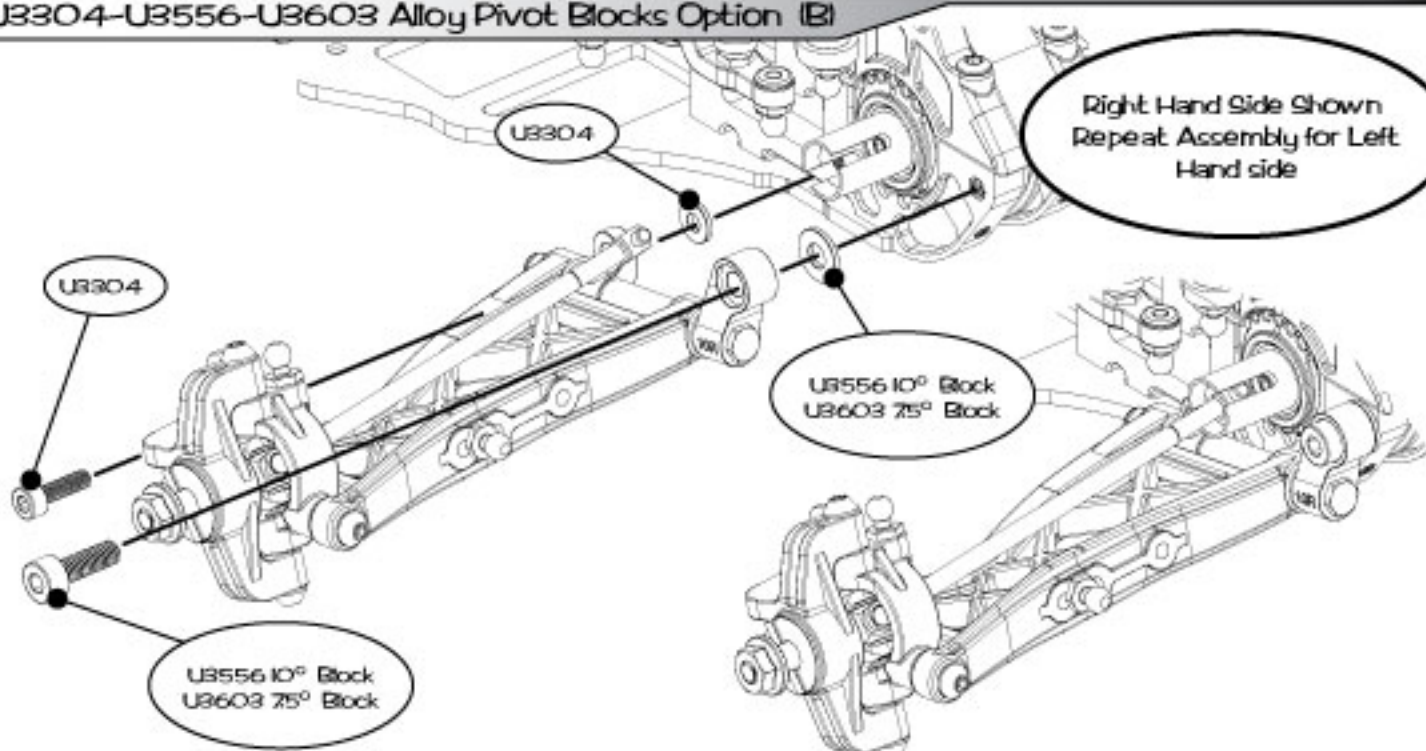

U3339 Alloy Eccentrics Option





### U3517 Alloy Pivot Blocks Rear Option (A)

# CAT

Competition - All - Terrain

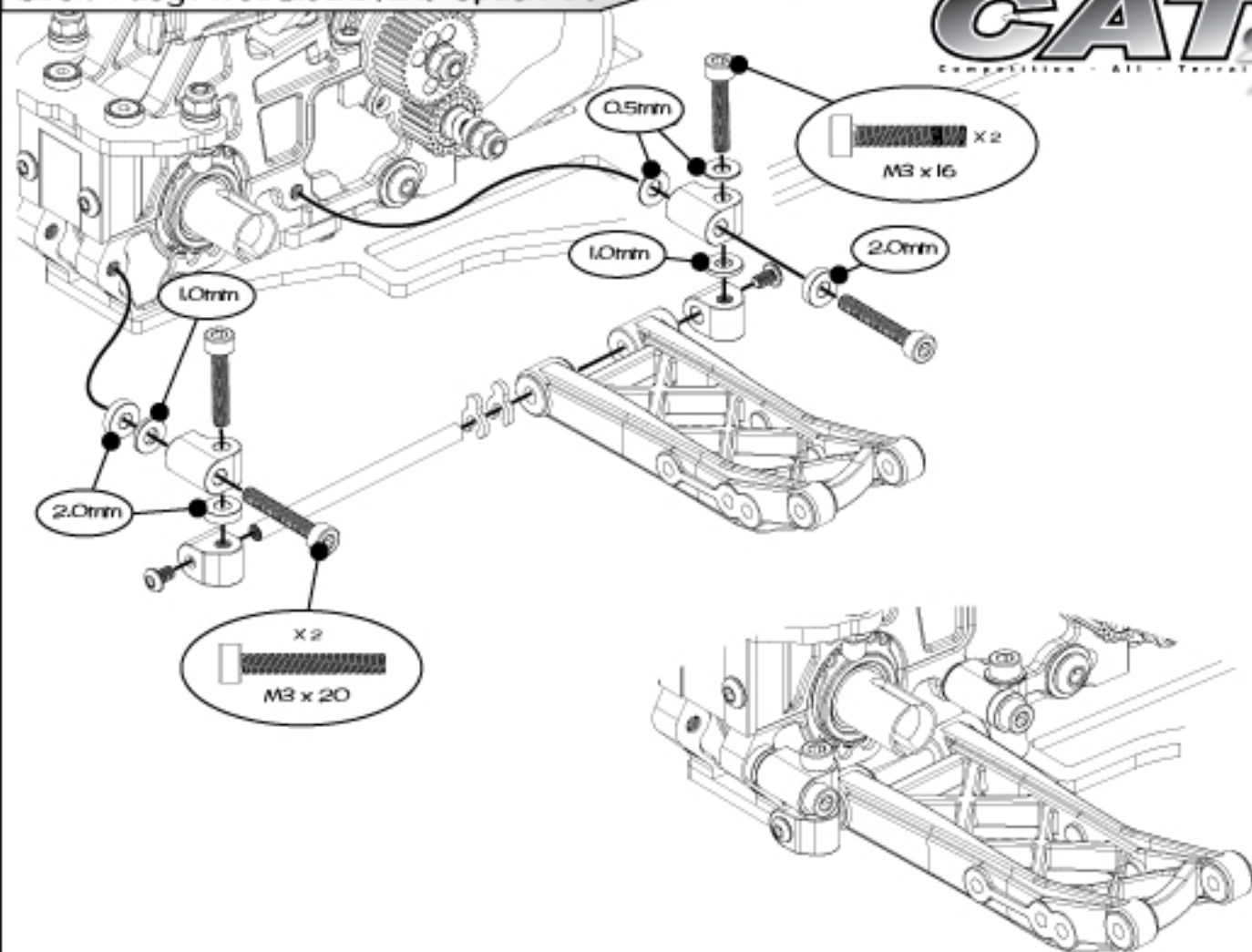

### U3517 Alloy Pivot Blocks Rear Option (B)

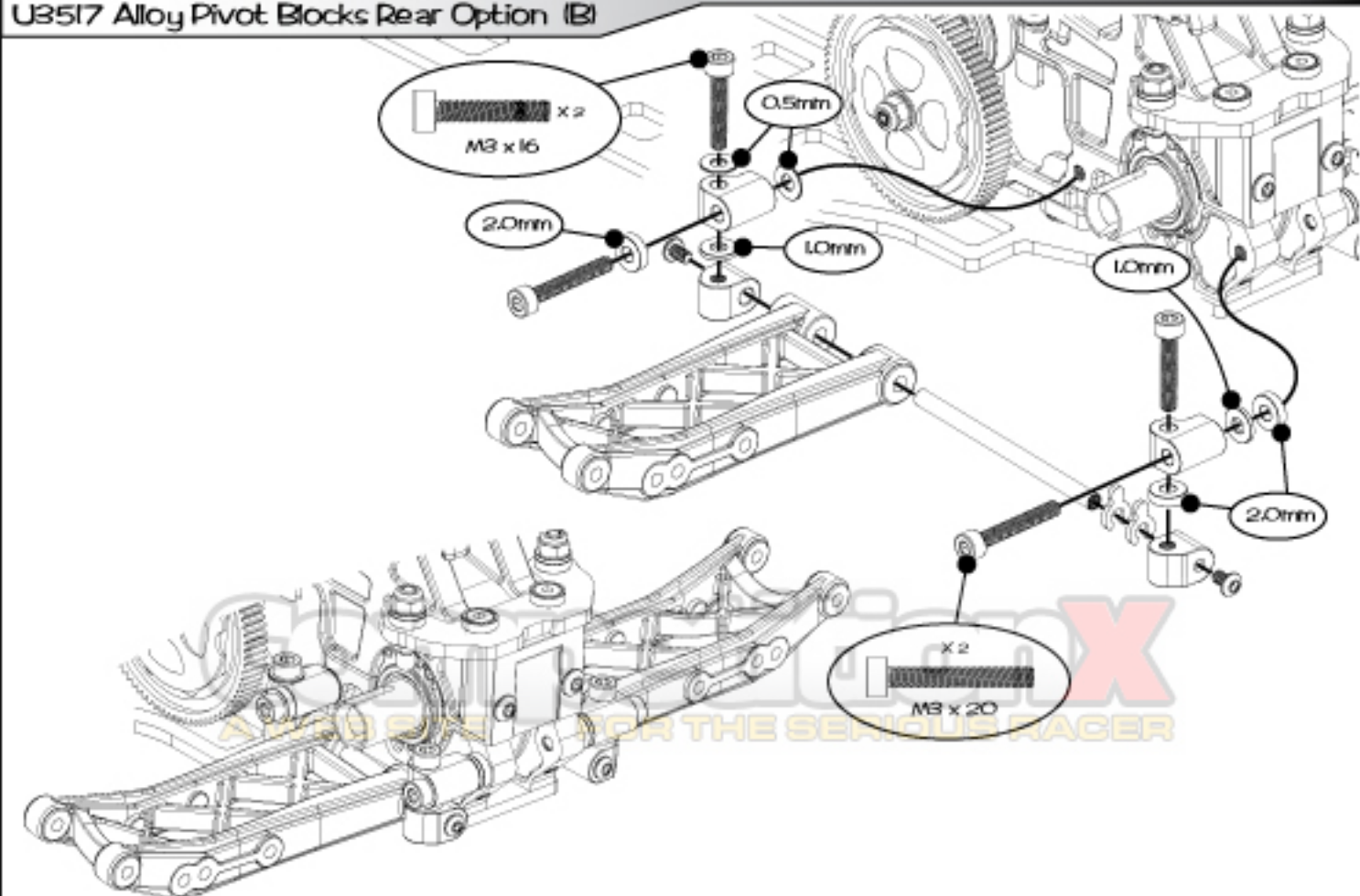

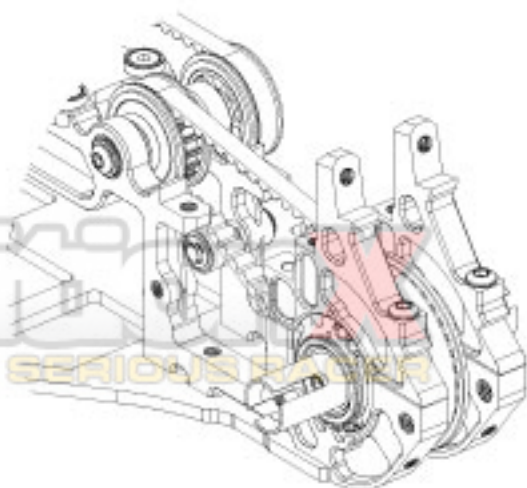
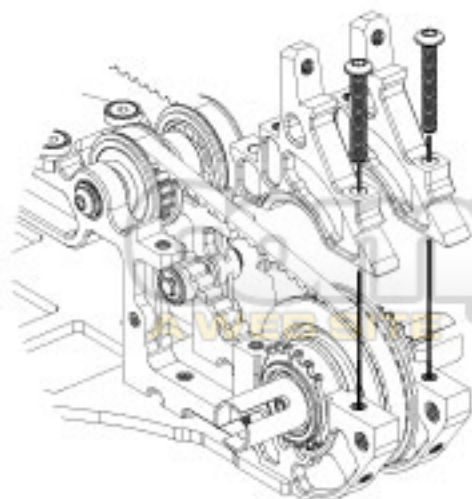
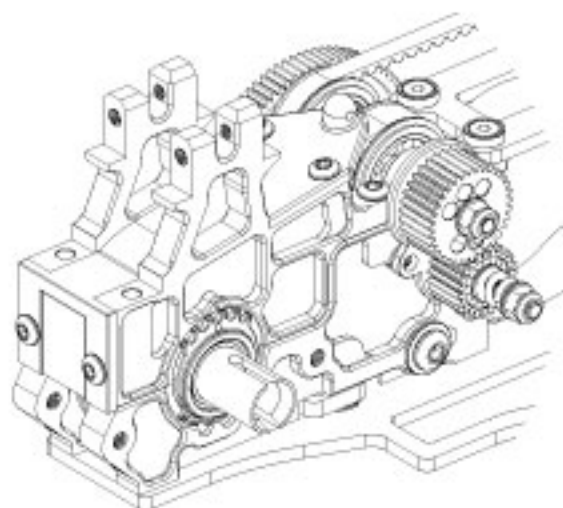
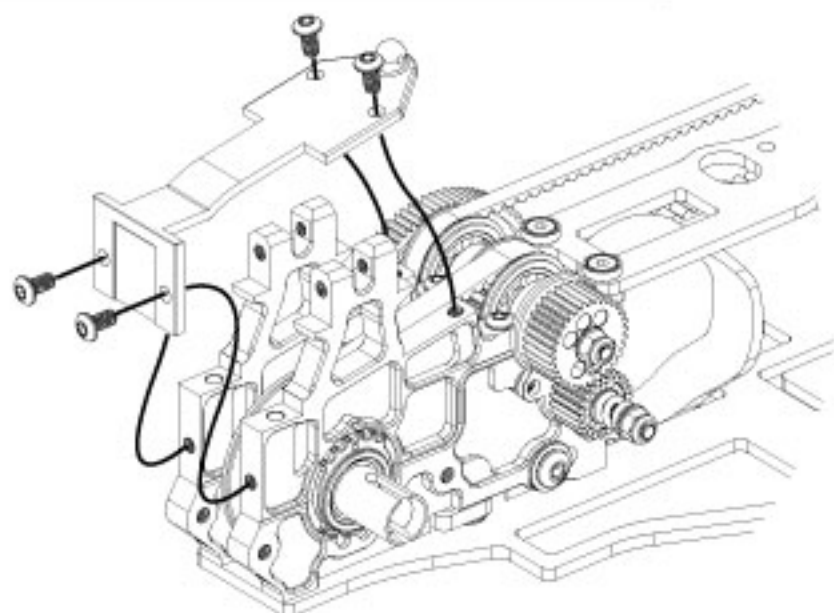
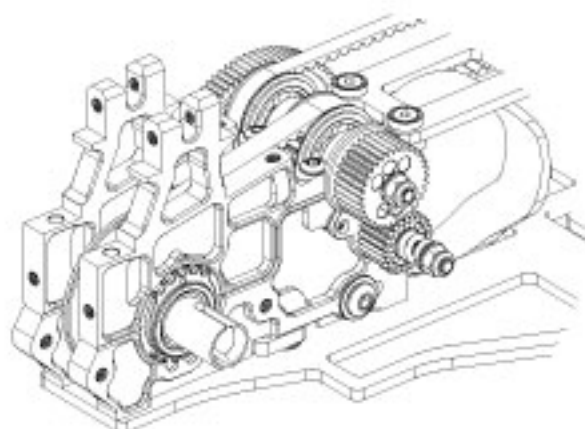
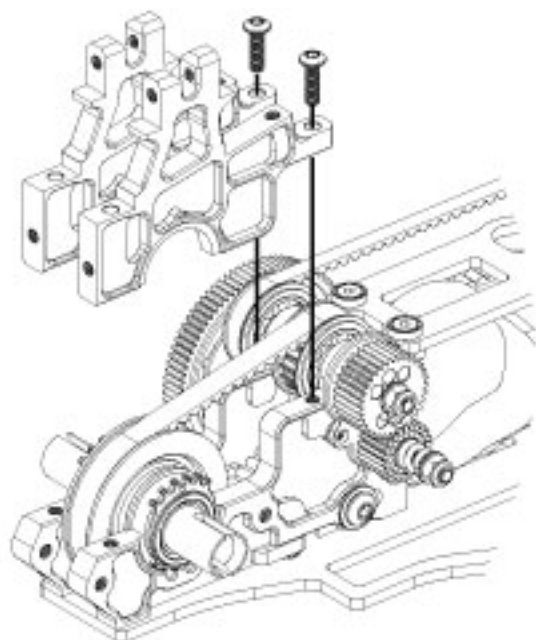

**WIPAC**  
A MEMBER OF THE SERIOUS PLAYERS GROUP



### U3605 1° Alloy Rear Hub Carrier Option

**CAT**  
Competition - All - Terrain

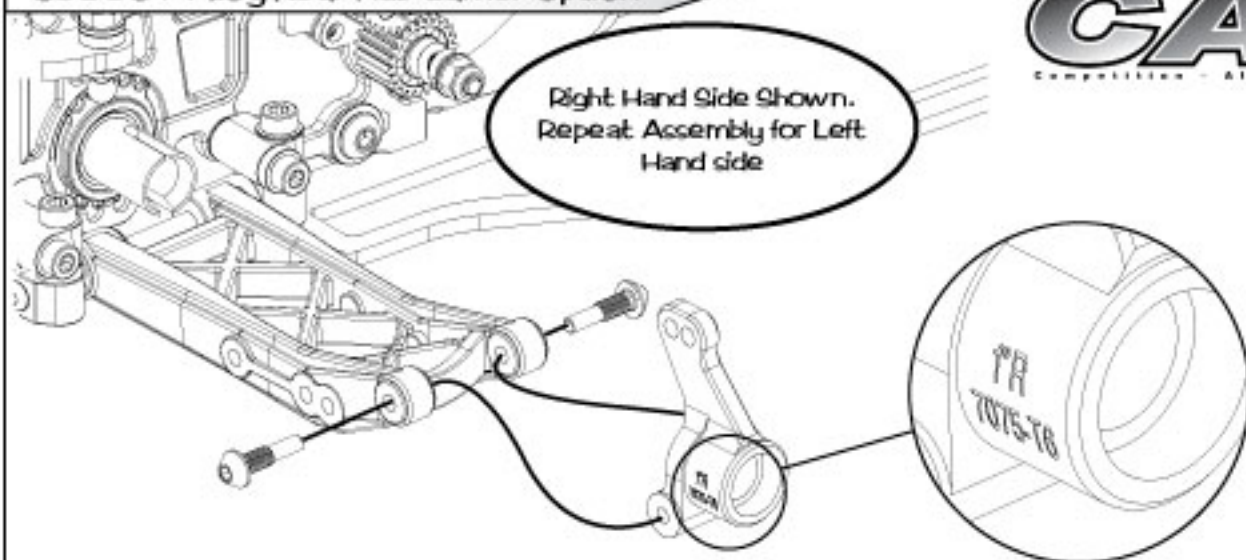

### U3559 12.5° - U3404 75° Alloy Yokes Option

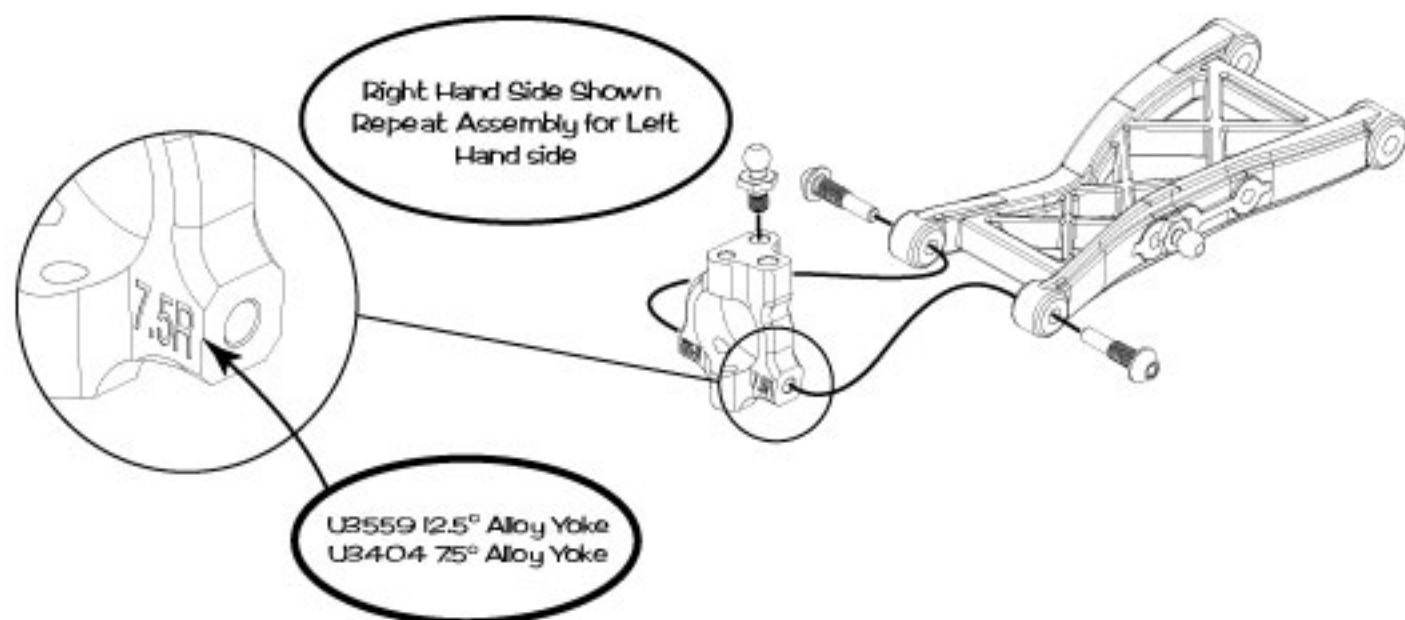

### U3611 Alloy Spring Seat Option

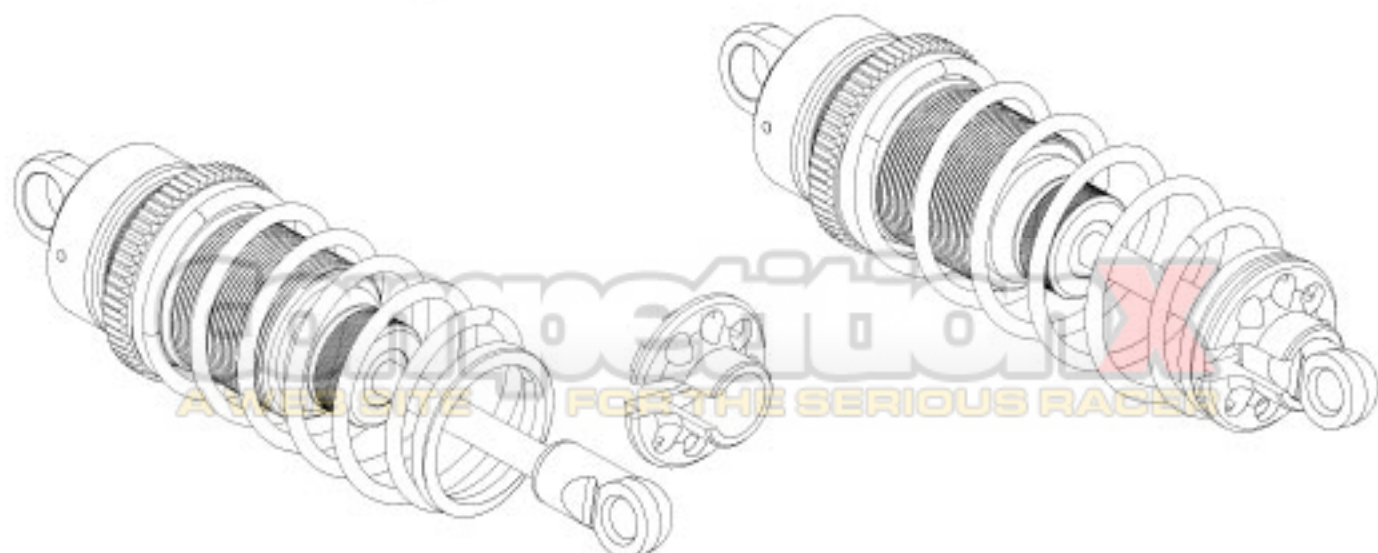

### U3769 Reverse Shock Conversion Option (A)

This Option Requires U3555 Alloy Upper Mount to be fitted to your car. Your Cat has the ability to run the shocks at the back of the Rear Wishbones as well as the front. This mounting position is recommended for tracks that are very Bumpy, as it will give the car extra stability. For less Bumpy tracks you should leave the shock mounting as standard

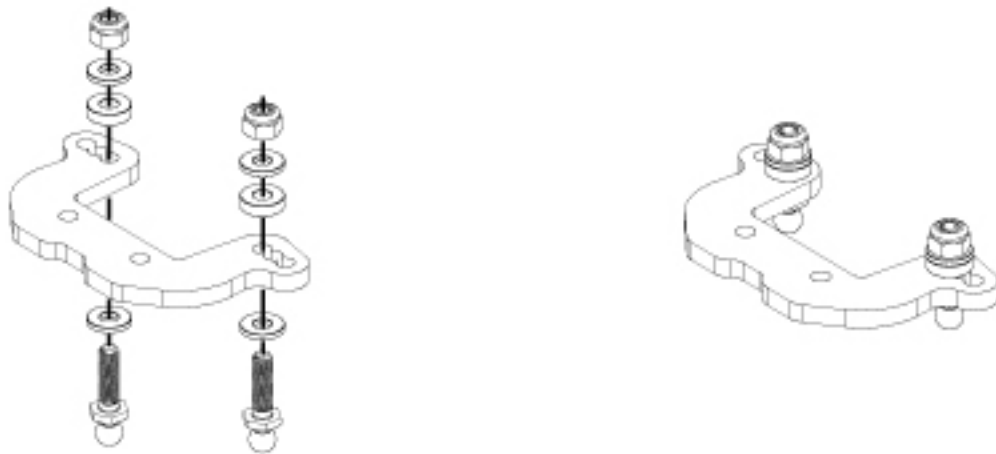

### U3769 Reverse Shock Conversion Option (B)

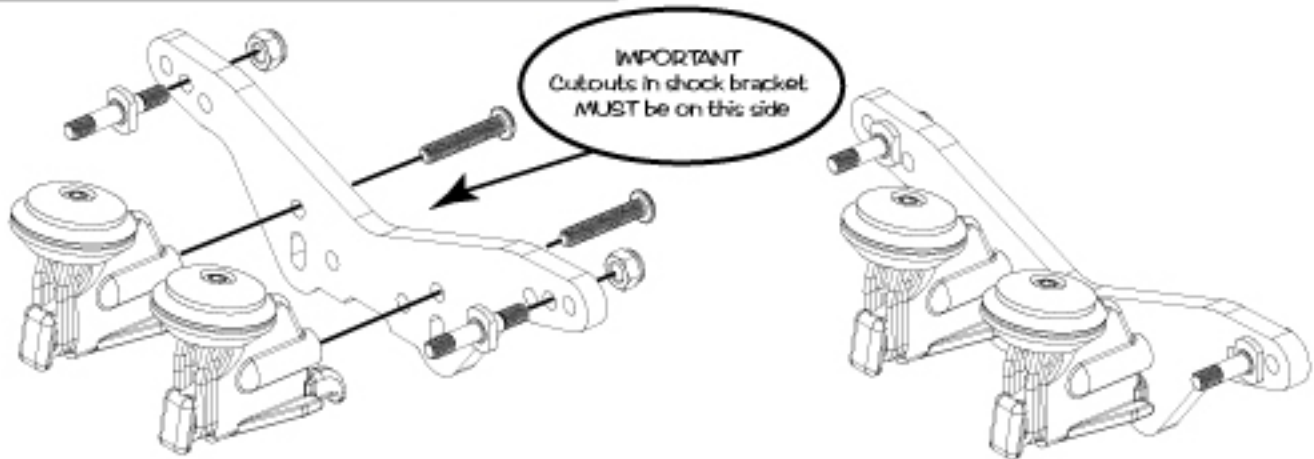

### U3769 Reverse Shock Conversion Option (C)

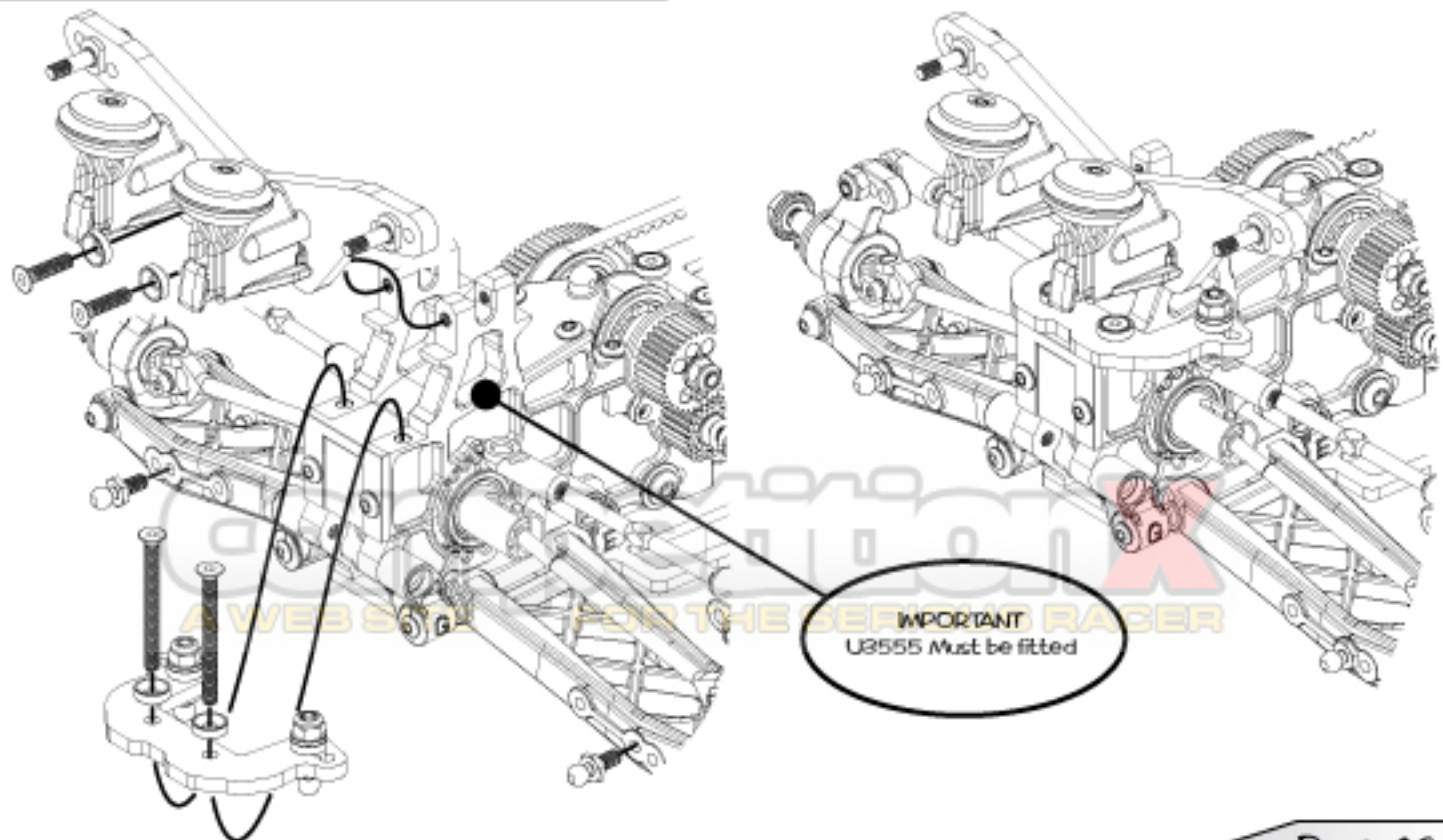



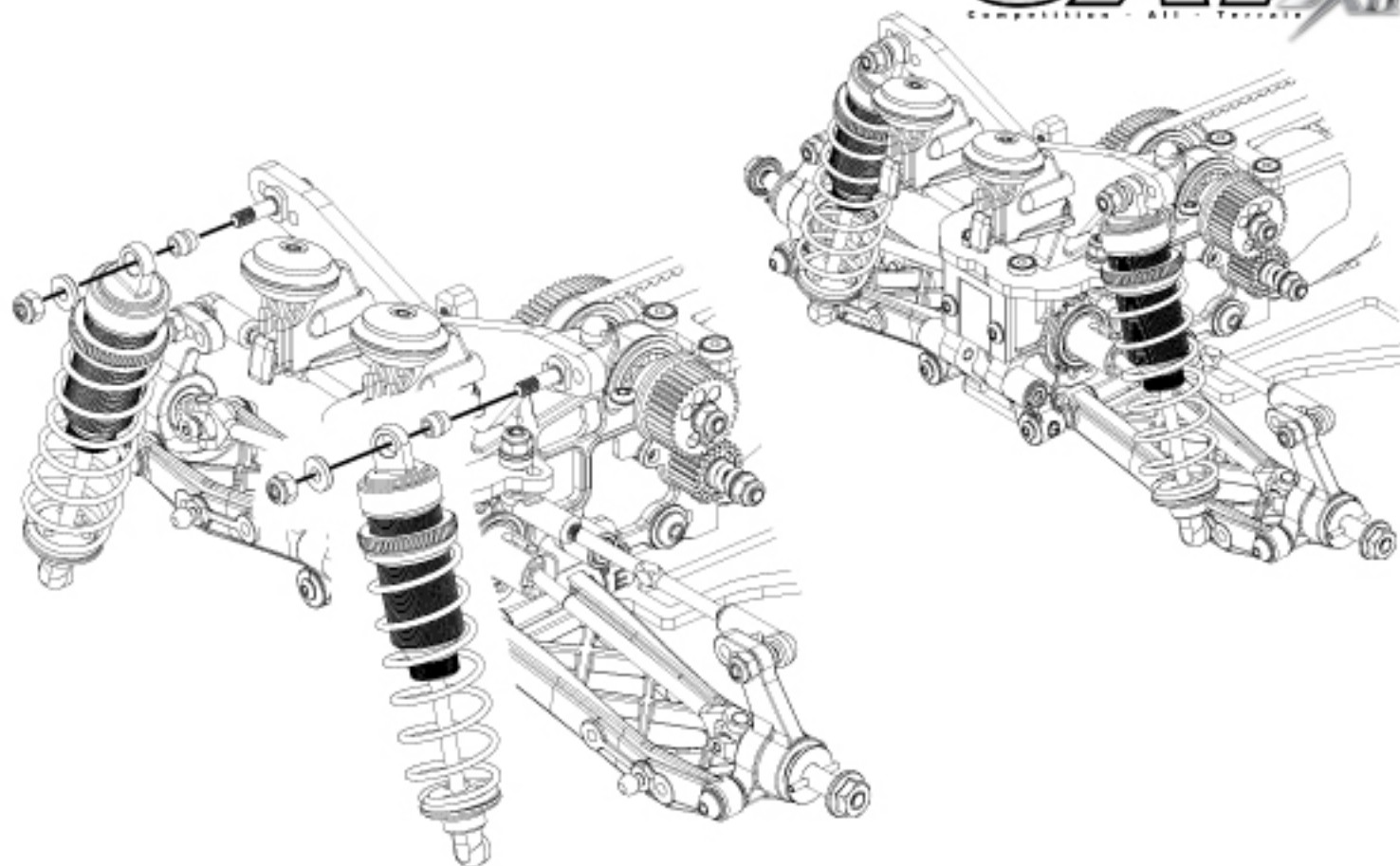

## Car Settings

### Differentials

For consistent performance it is vital that the differential action should be smooth and free. The diff should be adjusted using the recommended settings in the manual. Diff adjustment is not a tuning aid and the diff should never be allowed to slip. A loose diff can usually be recognised by a 'chirping' sound when powering away from turns or landing under power from large jumps. When re building your diff we recommend using a U1954 thrust race and U3019 ceramic nitride balls for ultimate reliability and weight saving.

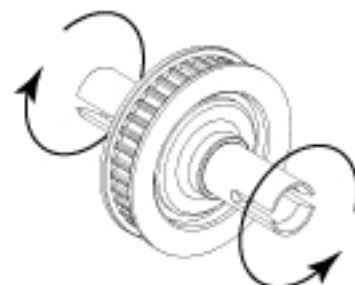

### Slipper Clutch

On most tracks it is best to start with the slipper on a tight setting, and gradually loosen the spring tension, until you achieve the most consistent drive away from turns without spinning the car or pulling wheelies. Make sure you still have enough drive when launching the car from the up ramps. **WARNING.** Do not run the slipper too loose as it could melt the plastic spur gear.

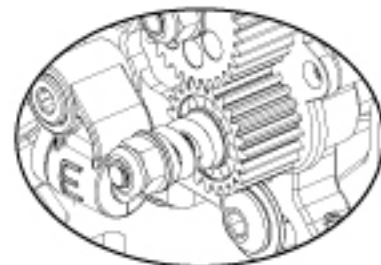

### Front Differential/Oneway

There are two main front drive options for the Cat. The kit standard differential (this is probably the best all round option for most drivers). And the speed secrets one way front axle. This provides really good on power drive. But absolutely no front braking. using this option gives the car great agility, steering and front traction but makes the car feel a little loose off power. Usually this provides the fastest individual laps but often lacks consistency over the entire run.



## Differential Height

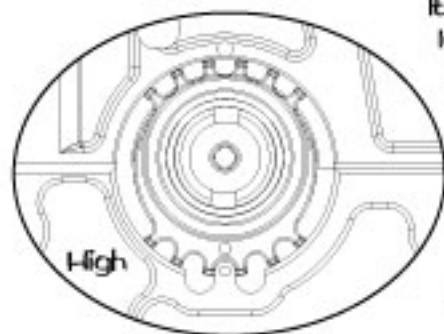

It is possible to run the Cat with the diff in the high or low position. When running on tracks with large jumps using the diff in the high position causes the driveshaft's to plunge more. The added friction of this can help make the car more stable on landing when under power. This setting could also help with traction on loose surfaces. For most normal tracks we would recommend running the diff in the low position for reduced driveshaft friction.

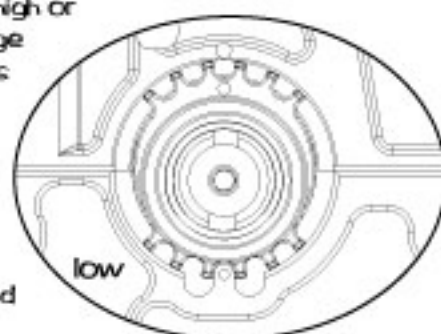

## Front Layshaft. Fixed, One way or F.A.B.

These option parts further extend the drive system permutations, i.e. front differential and layshaft one way, front differential and F.A.B or for minimum overrun inertia a one way layshaft and a one way front axle. The F.A.B system is basically a front one way drive pulley with an adjustable slipper system to vary the amount of braking available to the front wheels. This is a very useful tuning aid where the one way offers too little braking, and a locked up system gives too much. Using a one way layshaft and a one way front axle will give the absolute minimum of overrun inertia. This set up is usually confined to high grip tracks. The option of a front diff with a one way layshaft has the advantage of being slightly smoother to drive and with better steering response through zig zag sections of the track where a one way front axle might feel a little nervous to drive.

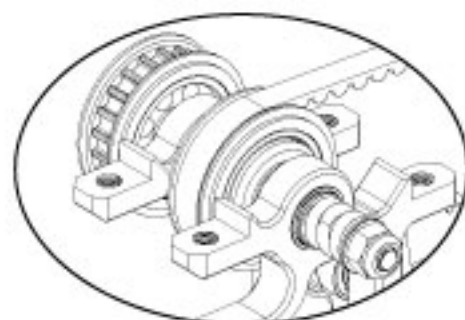

## Ride Height

Use the spring adjusters on the shock absorbers to adjust the front and rear ride heights. We would recommend setting the ride height to around 20 mm with the car level. This is measured between the bottom of the chassis and the ground with the car in running trim. First press the car down on to the ground and release it once or twice to settle the suspension before adjusting the ride height. The chassis should be level when viewed from the side.

Adjusting the spring collars does not increase or decrease the spring stiffness only the preload. So if the suspension needs to be softer or harder change the spring.

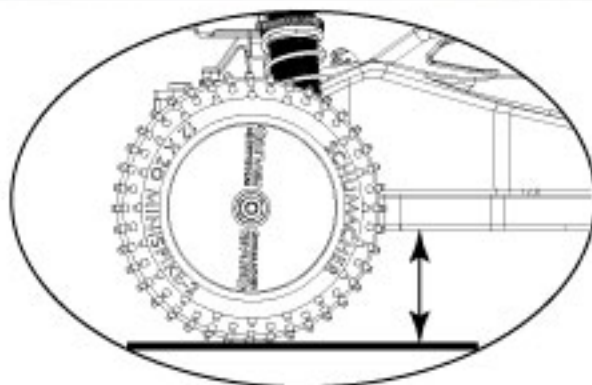

## Anti Roll Bars

Anti roll bars are an often overlooked set up aid that allows fine tuning of the suspension without major changes to the shock and spring settings. They are mainly used to add roll stiffness to the car without affecting the handling on bumps and jumps. Running roll bars allows you to run softer suspension on bumpy tracks while reducing the roll in corners thus maintaining stability through the turns.

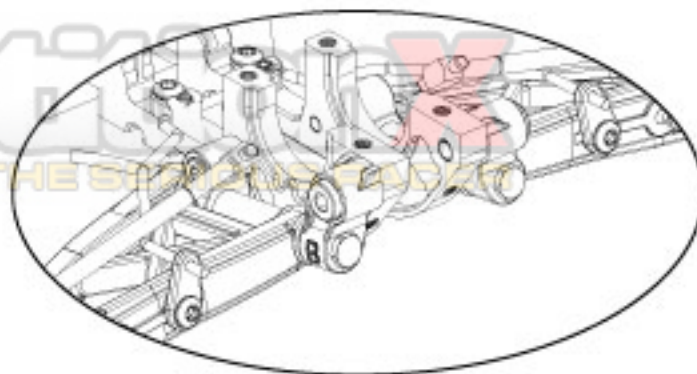
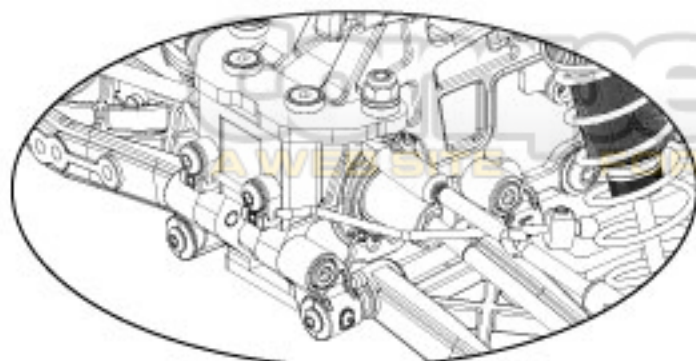



## Front Toe In

Front toe in should be set to 0° (both front wheels pointing straight ahead) this will be the best setting for most track conditions. Adding slight toe out will increase initial turn in. Whereas slight toe in will make this initial turn in a little softer.

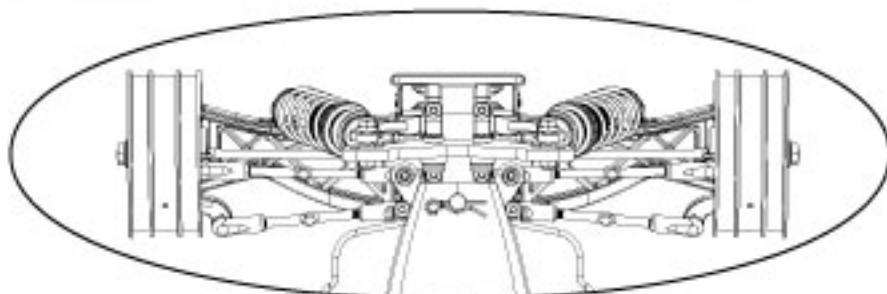

## Front Wishbone Shock Mounting Hole

The middle hole in the wishbone is the standard setting for the lower shock absorber mounting. Moving the shock absorber to the outer hole increases the reaction of the steering as well as increasing the suspension stiffness. This position may cause a little too much initial turn in on corner approach. Using the inside hole will soften the suspension and also increase the total suspension travel, and will probably need spring and damping changes to make the best use of it.

Anti roll bars are a good tuning aid when using different shock absorber positions on the wishbone.

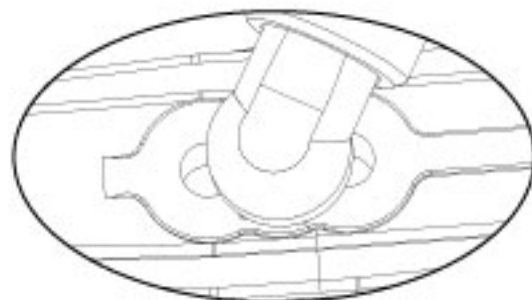

## Front Camber Links

The kit front camber link position and length are what the Team recommend for most tracks. Using a long front link makes the front of the car roll more and will give less steering reaction at high speed. It is also not quite as good on very bumpy tracks. We would probably recommend this on fairly smooth high grip tracks. A shorter front link will make the car roll less and quicken the initial steering response. This is a better choice for bumpy low grip tracks. Lowering the inside ball stud will give a similar result to shortening the link, and raising it will give a similar result to lengthening the camber link, but with less total effect.

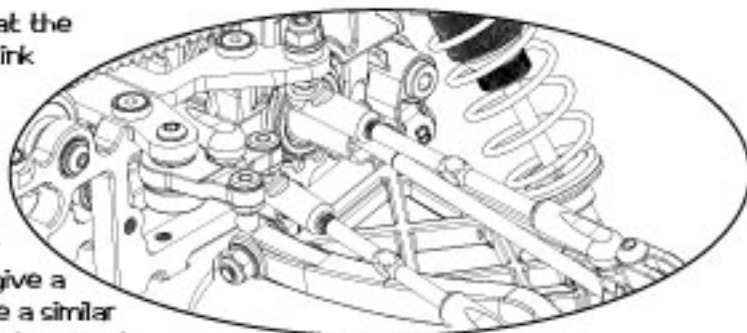

## Front Camber

The usual team setting for static front camber is 1° negative at ride height (the top of the wheel is leaning inwards towards the car). Increasing the static camber will generally increase the mid corner steering, whereas decreasing the static camber usually makes the car smoother to drive by reducing the steering response.

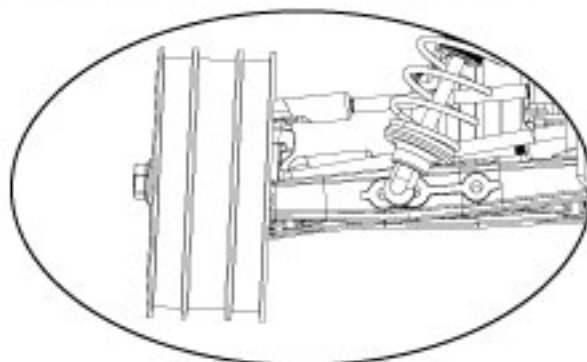

## Front Rake Adjustment

The Std rake angle (kick up) is 10° on the Cat and needs adding to the caster block angle to get the total caster angle. The standard car uses a 10° caster block making the standard car 20° in total; this can be increased to 22.5° by using the optional 12.5° caster block. Or 175° by using the optional 75° caster block. Using more caster gives better corner entry steering but less power on steering at corner exit, and will make the steering feel a little softer. There is also the 75° Rake Blocks which again will reduce the total caster angles by 2.5°.

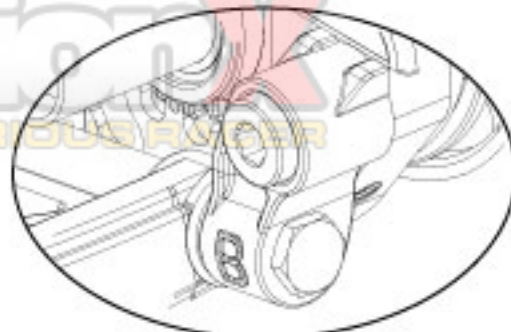



## Front Shock Mount

The middle hole on the front shock mount is the most widely used position. Moving the shock to the outer position will make the car react faster and increase the initial steering response, it will however, stiffen the suspension which may require an oil and spring change so that the cars suspension feels the same. By moving the shock to the inner hole will soften the suspension and slow down the steering reaction and make the car smoother on bumpy tracks. You may need to alter the oil and spring combination to get the suspension correct again.

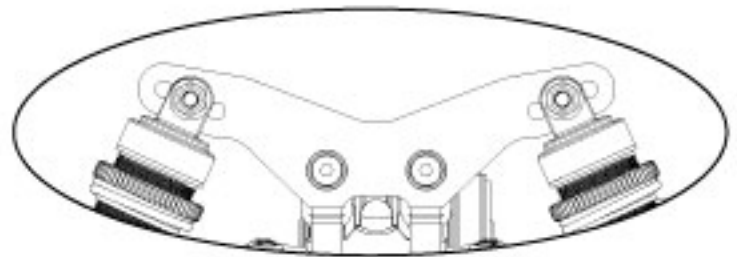

## Rear Camber

The usual team setting for static rear camber is  $\text{P}^-$  negative at ride height (the top of the tyre leaning inwards towards the car). Increasing the static rear camber will increase the traction when exiting the turns, but will be less stable at high speed. Decreasing the camber will reduce stability and traction in the turns but will be more stable at high speed. Some drivers believe that adding slight positive camber where the tyre leans out at the top away from the car, will improve straight line traction on loose surfaces!

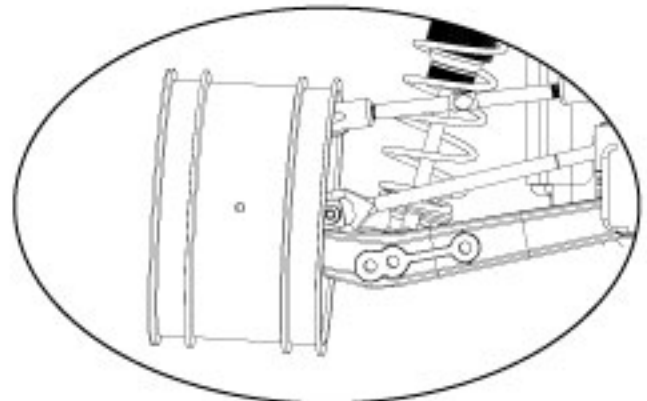

## Rear Camber Link

The kit build rear camber link setting is the best compromise for most tracks. This is the longest link option and gives good stability and straight line traction while allowing the rear of the car to free up on high speed turns. This reduces power on under steer on high grip tracks.

Shortening the rear camber link will make the rear of the car roll less in the corners, and square up faster when accelerating away from tight turns, longer links are generally used on high grip tracks and shorter links on low grip tracks. Lowering the inside ball stud will give a similar result to shortening the link, and raising it will give a similar result to lengthening the camber link, but with less total effect.

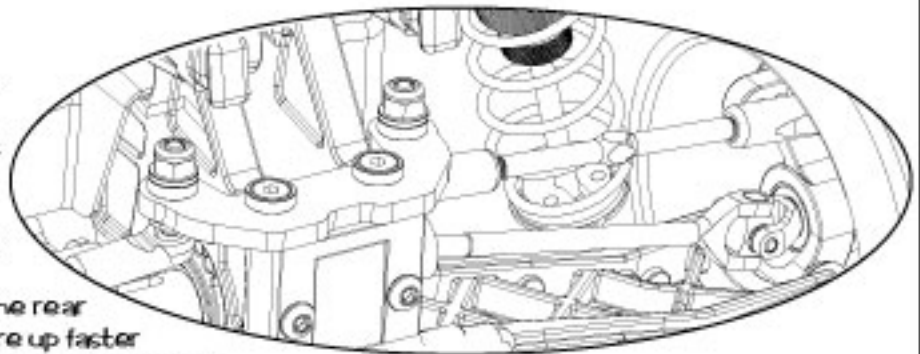

## Rear Anti Squat

The standard anti squat is set at  $2^\circ$ . The Team have found that this works Best on most tracks, and With optional parts this can be increased or Decreased.

Generally less anti squat allows the suspension to work better over the large bumps but usually gives less power on traction. Adding more antisquat gives more forward traction up to the point where the car starts to pull wheelies. Backing off the slipper is not always an option to compensate for this as good initial bite is needed to clear big jumps. Adding more antisquat seems to make the car handle better over small ripples but not so good on the tracks with large bumps.

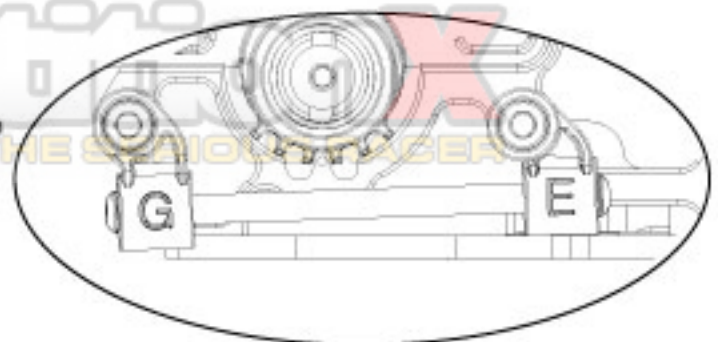



## Rear Wishbone Shock Mounting Hole

The inner hole works best for most track conditions giving good traction and drive through the turns whilst maintaining good stability over the bumps. Moving to the outer hole on the wishbone will decrease traction but will allow the rear to free up more in the turns. This setting would usually only get used on high grip tracks and when moving the shock out you may have to change the oil and spring settings to get the same suspension feel.

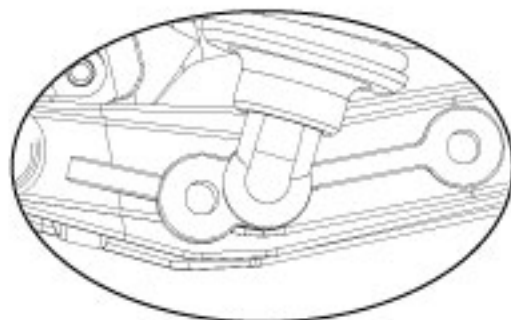

## Rear Toe In

The standard rear toe in is 3° this is a good compromise between forward traction and the car binding in the turns, this setting is fine for most tracks. You can alter the toe in with option blocks. If you are running too much toe in your car may suffer from instability at high speeds, decreasing the toe in will reduce forward traction but will free the car up in the turns. Usually the Team use less toe in on high grip tracks and more for low grip tracks.

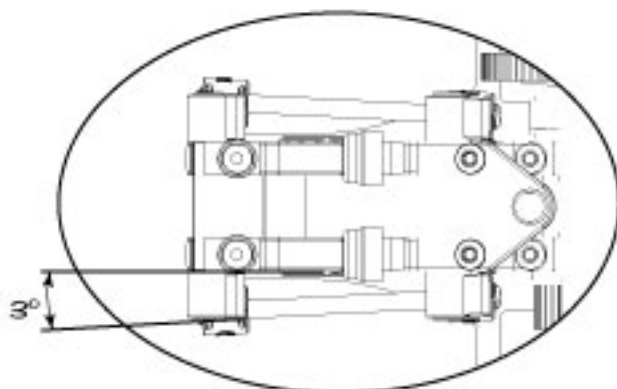

## Wheel Base Adjustment

The Cat has 3 wheelbase options at the rear: short, med and long. The adjustment is provided by re positioning the quick clips on the wishbone pin. Moving the rear wishbones forward will give more traction at the expense of stability over rough sections of the track, and moving the wishbone to the middle or rear position usually improves stability over the rough sections, running the car in long wheelbase form also free's up the car on sweeping sections of the track.

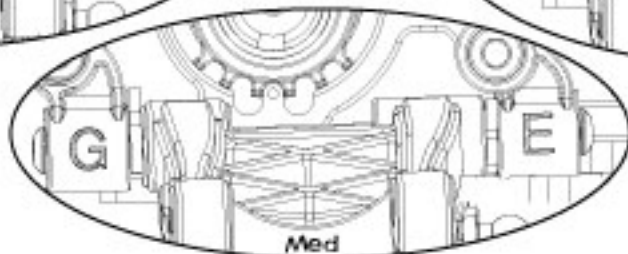
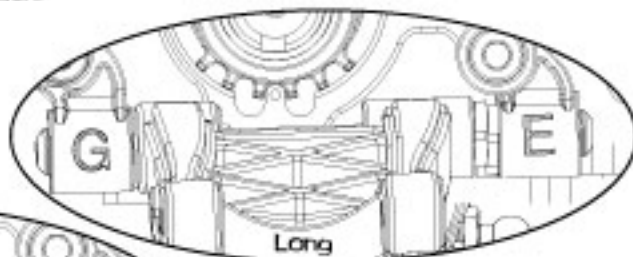
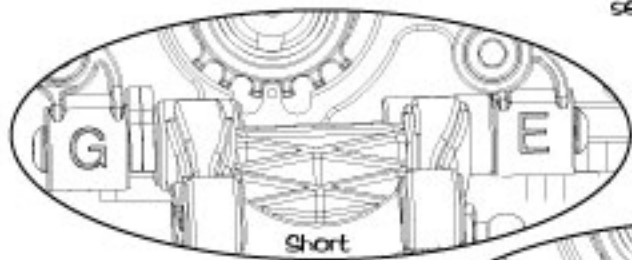

## Rear Shock Mount

The middle hole on the shock mount gives best all round results. Moving the shock to the outer hole will stiffen the suspension and increase the reaction of the steering. The downside is less compliance over bumpy sections of the track. Moving the shock to the inboard position softens the suspension and will slow the steering reaction making the car smoother over the bumps. Moving the shock to these holes may require an oil or spring change to maintain the suspension performance.

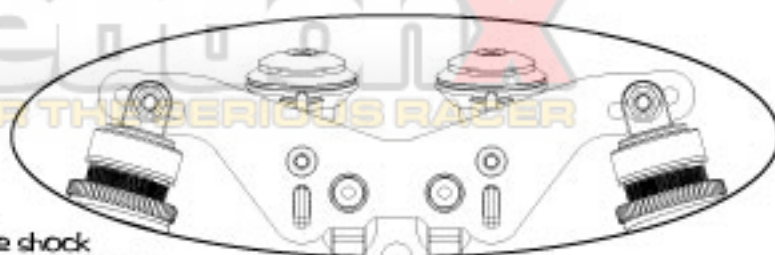

Traditionally 4WD cars have always used an internal ratio between 2.4:1 and 2.6:1. The Standard Cat Ratio is 2.6:1 with the option to run either 2.4:1 or 2.8:1 with optional parts. One advantage of these interchangeable ratio's is that it is possible to adjust the motor position whilst maintaining the same overall gearing.

## 2.8:1

We Class this as a High inertia ratio, as the layshaft for the same overall gearing will be rotating faster than the other available ratios. This will give you a smooth driving transmission, spooling up and down without major reactions from throttle input. Good for loose surfaces.



	16	17	18	19	20	21	22	23	24	25	26	27	28
83	14.51	13.65	12.90	12.22	11.61	11.05	10.55	10.09	9.67	9.28			
82		13.49	12.74	12.07	11.47	10.92	10.42	9.97	9.55	9.17	8.82		
81			12.58	11.92	11.33	10.79	10.30	9.85	9.44	9.06	8.71	8.39	
80				11.77	11.19	10.65	10.17	9.73	9.32	8.95	8.60	8.29	7.99

Tooth Sum 99 Minimum IOB Maximum

## 2.6:1

We Class this as a Medium inertia ratio, as the layshaft for the same overall gearing will be rotating at speeds between the other available ratios. This will result in a transmission that has a good balance of sharp response and smooth transmission.

This Kit Ratio is Recommended for most applications

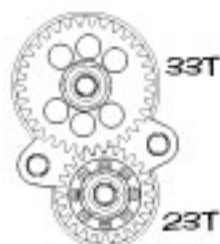

	16	17	18	19	20	21	22	23	24	25	26	27	28
83	13.47	12.68	11.97	11.34	10.77	10.26	9.80	9.37	8.98	8.62			
82		12.52	11.83	11.20	10.65	10.14	9.68	9.26	8.87	8.52	8.19		
81			11.68	11.07	10.51	10.01	9.56	9.14	8.76	8.41	8.09	7.79	
80				10.93	10.39	9.89	9.44	9.03	8.65	8.31	7.99	7.69	7.42

Tooth Sum 99 Minimum IOB Maximum

## 2.4:1

We Class this as a Low inertia ratio, as the layshaft for the same overall gearing will be rotating slower than the other available ratios. This will result in a faster reacting transmission, with sharper responses to throttle and brake input. Good for High Grip situations.



	16	17	18	19	20	21	22	23	24	25	26	27	28
83	12.52	11.78	11.13	10.54	10.01	9.54	9.10	8.71	8.34	8.01			
82		11.64	10.99	10.41	9.89	9.42	8.99	8.60	8.24	7.91	7.61		
81			10.86	10.29	9.77	9.31	8.88	8.50	8.14	7.82	7.52	7.24	
80				10.16	9.65	9.19	8.77	8.39	8.04	7.72	7.42	7.15	6.89

Tooth Sum 99 Minimum IOB Maximum

## Speed Secrets

U3345 Gear: CNC 32T Idler  
U3346 Gear: CNC 33T Idler (kit)  
U3347 Gear: CNC 34T Idler



U3342 Gear: CNC 22T Layshaft  
U3343 Gear: CNC 23T Layshaft (kit)  
U3344 Gear: CNC 24T Layshaft



A WEB SITE FOR THE SERIOUS RAGER