

Futaba®

DIGITAL PROPORTIONAL
RADIO CONTROL

MAGNUM SPORT FP-2P

INSTRUCTION MANUAL

Pistol Grip, AM 2-Channel,
2-Servos



Thank you for purchasing a Futaba digital proportional radio control set.
Please read this manual carefully before using your set.



FUTABA CORPORATION OF AMERICA
FUTABA CORPORATION

D60906

FEATURES OF MAGNUM SPORT

The Magnum series are pistol grip type of AM 2 channel digital proportional radio control sets.

TRANSMITTER FP-T2P

- Human-engineered size and design are easy to use.
- **Wheel angle adjuster.** The turning angle of the steering wheel can be increased and decreased. This allows operation at the best angle.
- **Neutral adjuster.** The throttle trigger throttle stroke/brake deflection stroke (back stroke) can be freely selected to match the application.
- **Servo reversing switch** (steering and throttle) is standard. Each servo can be reversed from the outside. This is extremely convenient when connecting the linkages.
- Since a level meter is provided, battery consumption can be seen at a glance.
- Crystals can be changed from the outside on 27MHz only as it is illegal to do this on 72MHz and 75MHz in U.S.A.

RECEIVER FP-R102GR

- BEC (Battery Eliminator Circuitry) system allows sharing of the running Nicd battery and eliminates the need for a regulator and diode.
- Crystal socket uses a new type of highly reliable subminiature pins. Reliability is increased and the crystal can be changed from the outside.

SERVO FP-S148, S129

- Motor uses the newest helical type rotor for improved output torque and smooth operation. (S129)
- These heavy-duty & water/dust tight servos are designed for use with Futaba digital proportional radio control sets. (S129)
- New **indirect driver potentiometer** improves vibration and shock resistance and increases neutral precision tremendously.
- Futaba **low-power custom IC** provides high starting torque, narrow dead band, and excellent trackability.
- **Fiberglass-reinforced PBT** (polybutylene terephthalate) injection molded servo case is mechanically strong and invulnerable against glow fuel.
- Strong **polyacetal resin ultra-precision servo gear** features smooth operation, positive neutral, and very little backlash.
- **Fiberglass-reinforced epoxy resin PC board with thru-the-hole plating** improves servo amp vibration and shock resistance.
- Thick film gold-plated connector pins eliminate poor contact and improve reliability against shock and vibration.
- Special grommet bushing simplifies servo mounting and improves the cushioning effect.
- Six special **adjustable splined horns** are available.
- Maximum output torque of 48.7 oz-in. (3.0kg-cm/3.5kg-cm) allows use in almost any model. (S148, S129)

SET CONTENTS AND RATINGS

(Specifications are subject to change without prior notice.)

	MAGNUM SPORT
Transmitter	FP-T2P
Receiver	FP-R102GR
Servo	FP-S148 x 2 or FP-S129 x 2
Others	Switch, battery holder, etc.

TRANSMITTER FP-T2P

Operating system : Pistol grip type, 2-channel
Transmitting frequency : 27MHz band 72/75MHz band
Modulation system : AM (amplitude modulation)
Power requirement : 12V, AA penlight battery x 8

RECEIVER FP-R102GR

Receiving frequency : 75MHz
Intermediate frequency : 455kHz
Selectivity : 3kHz/-3dB
Receiving range : 550 yards (500m) on the ground when used with FP-T2P (At the best radio wave condition of environment)

Power supply : 4.8V to 8.4V
Current drain : 7.2V/13mA, 4.8V/33mA
Dimensions : 1.46 x 2.19 x 0.75 in. (37 x 55.5 x 19 mm)
Weight : 1.34 oz. (38g)

SERVO FP-S148

Control system : +pulse width control
Operating angle : One side 45° or more
Power requirement : 4.8V-6V
Current drain (IDLE) : 6.0V, 8mA (at idle)
Output torque : 42 oz. in. (3 kg-cm)
Operating speed : 0.22 sec/60°
Dimensions : 1.59 x 0.77 x 1.4 in. (40.4 x 19.8 x 36 mm)
Weight : 1.5 oz. (44.4g)

SERVO FP-S129

Control system : +pulse control
Operating angle : Rotary system, one-side 45° or greater (including trim)
Power requirement : 4.8V or 6.0V (shared with receiver)
Current drain : 6.0V, 8mA (at idle)
Output torque : 48.7 oz-in. (3.5kg-cm)
Operating speed : 0.25 sec./60°
Dimensions : 1.79 x 0.9 x 1.71 in. (45.5 x 23 x 43.5mm)
Weight : 2.1 oz (60g)

TRANSMITTER FP-T2P HANDLING INSTRUCTIONS

The name of each part of the transmitter is shown in Fig. 1 and Fig. 2. Learn them before operating your set.

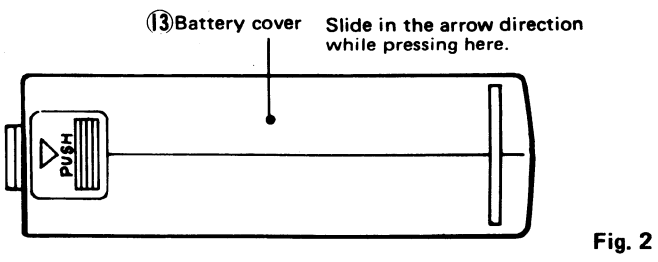
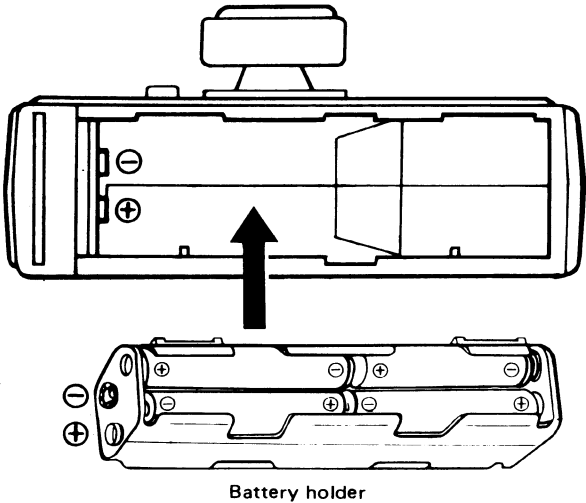
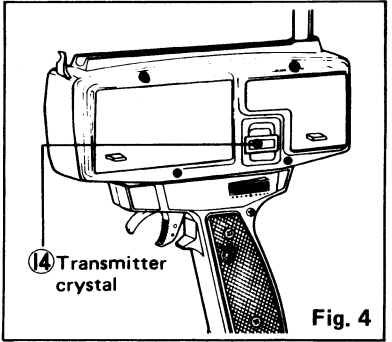
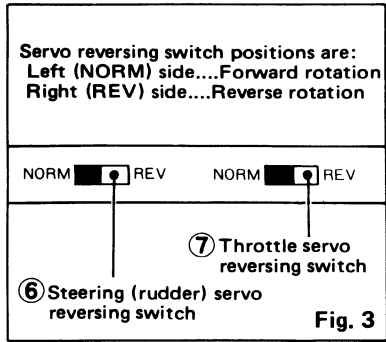
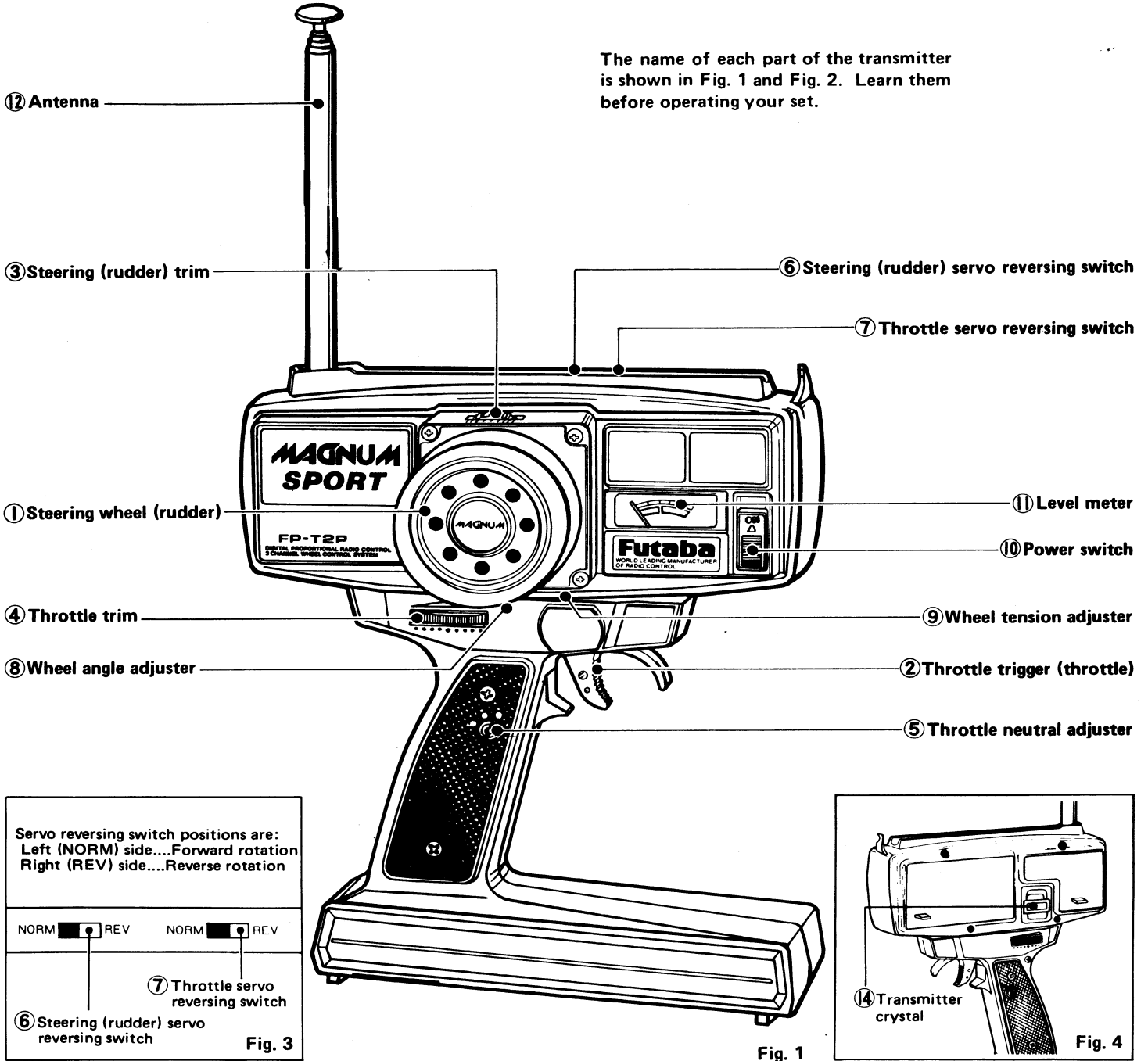

- Remove the battery cover and load eight penlight batteries into the battery holder in the correct polarity.
- When the antenna is extended to its full length and the power switch is turned on, the level pointer should deflect to within the silver zone. If the pointer does not deflect, or deflects very little, check for poor battery contact, incorrect battery polarity, or faulty batteries.

The servo reversing switches are assumed to be in the normal position in the descriptions in this section. When the servo switches are in the reverse position, operation is the opposite of that described here.

① **Steering wheel (rudder)**

Steering (rudder) operation.

② **Throttle trigger (throttle lever)**

Engine control/motor control operation.

The throttle neutral position can be set to one of three positions by turning the ⑤ throttle neutral adjuster with a coin as shown in Fig. 5. Set it to match the application.

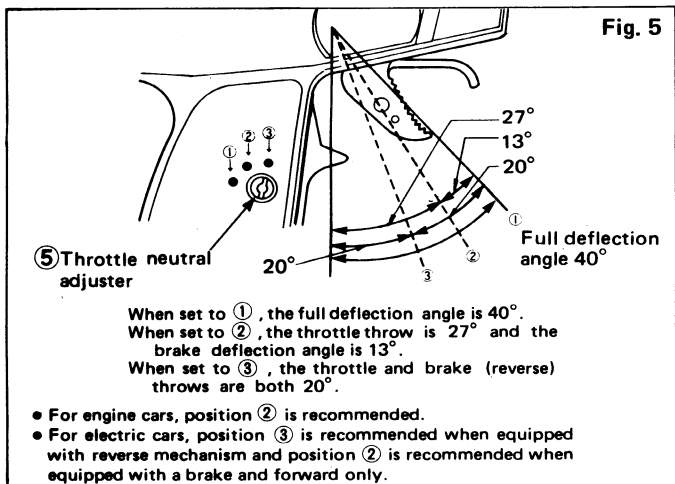

③ **Steering trim**

Steering (rudder) trim

④ **Throttle trim**

⑤ **Throttle neutral adjuster**

This adjuster sets the throttle trigger neutral point as described in ② throttle trigger. Set it to the point at which it stops with a click with a screwdriver, coin, etc.

⑥ **Steering (rudder) servo reversing switch**

⑦ **Throttle servo reversing switch**

⑧ **Wheel angle adjuster**

The wheel angle adjuster changes the operating angle of the ① steering wheel as shown in Fig. 6.

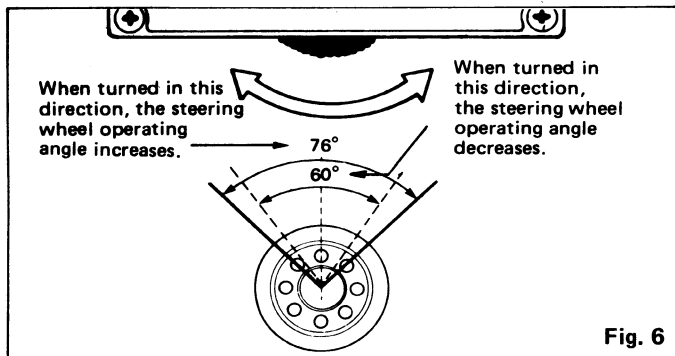

⑨ **Wheel tension adjuster**

This is a phillips head screw which adjusts the steering force of the steering wheel.

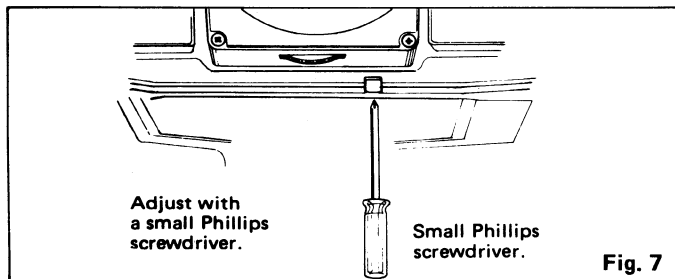

⑩ **Power switch**

When set in the direction of the ▲ mark (upper position), the switch is turned on and the pointer of the level meter deflects.

⑪ **Level meter**

When the ⑩ power switch is set to ON, the level meter pointer should deflect to within the silver zone. If the pointer stops near the boundary between the silver and red zones, the battery is low, and the range of the radiowaves will be short. When the level meter pointer drops to the boundary between the silver and red zones, change the battery.

⑫ **Antenna**

95cm antenna. It screws in vertically as shown in Fig. 8.

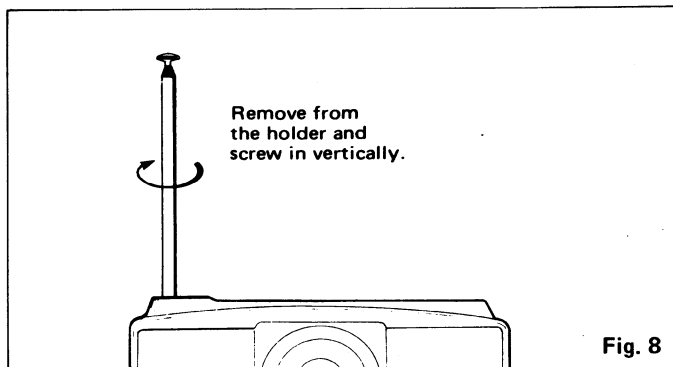

⑬ **Battery cover**

When loading (or changing) the eight penlight batteries, remove this cover as shown in Fig. 2.

⑭ **Transmitter crystal**

When changing the frequency, replace this crystal. Use the AM crystal set (transmit and receive 1 pair) sold by Futaba. The transmitter crystal is marked TX and the receiver crystal is marked RX. However, you are not allowed to change frequency by merely replacing crystal on both 72 and 75MHz.

Futaba. Digital Proportional Frequencies (For U.S.A.)

- The frequency of Futaba digital proportional sets can be changed among bands (1) ~ (6) on the 27MHz band only.
- However, a 27MHz band set cannot be changed to 72MHz band, and vice versa.
- Therefore, always attach the correct frequency flag to the end of the transmitter antenna. Each frequency band has its own designated color, as stated above. The frequency flag is intended for identification purposes.
- Also change the frequency flag when frequency is changed.
- Futaba paired crystals are precisely matched. Always use a Futaba crystal set (transmitter, receiver) when changing the frequency.
- It is illegal to change crystals of transmitter on the 72-75MHz bands in the U.S.A.

Frequency Channel No. Flag Color

26-27MHz - Aircraft/Car/Boat		75MHz - Car & Boat only	
26.995	- Brown	75.430	62 Blue-Red
27.045	- Red		(Top Flag/Ribbon- Bottom Flag/Ribbon)
27.095	- Orange	75.470	64 Blue-Yellow
27.145	- Yellow	75.510	66 Blue-Blue
27.195	- Green	75.550	68 Blue-Gray
27.255	- Blue	75.590	70 Purple-Black
		75.670	74 Purple-Yellow
		75.710	76 Purple-Blue
		75.750	78 Purple-Gray
		75.790	80 Grey-Black
		75.830	82 Grey-Red
		75.870	84 Grey-Yellow
72/75MHz - Aircraft only *Shared		53MHz - Aircraft/Car/Boat - FCC Amateur License Required	
72.030	12 Brown-Red	53.100	- Black/Brown
	(Top Flag/Ribbon- Bottom Flag/Ribbon)	53.200	- Black/Red
72.080	- White/Brown	53.300	- Black/Orange
72.160*	- White/Blue	53.400	- Black/Yellow
72.240	- White/Red	53.500	- Black/Green
72.320*	- White/Purple	53.600	- Black/Blue
72.400	- White/Orange	53.700	- Black/Purple
72.550	38 Orange-Grey	53.800	- Black/Grey
72.590	40 Yellow-Black		
72.630	42 Yellow-Red		
72.670	44 Yellow-Yellow		
72.710	46 Yellow-Blue		
72.750	48 Yellow-Grey		
72.790	50 Green-Black		
72.830	52 Green-Red		
72.870	54 Green-Yellow		
72.910	56 Green-Blue		
72.950*	- White/Yellow		
75.640	- White/Green		



The **BEC** mark is displayed on the front of the receiver of BEC (Battery Eliminator Circuitry) system sets with a receiver with shared power supply regulator.

RECEIVER FP-R102GR AND SERVO FP-S148

Fig. 9

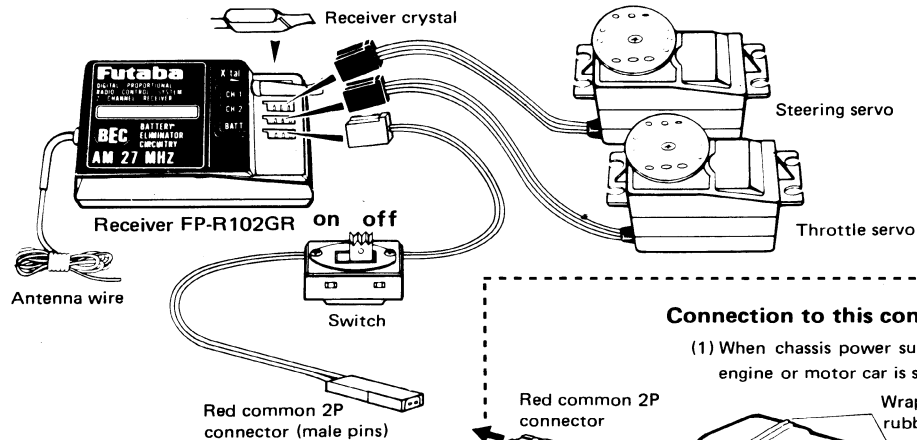

Connect the servo and switch as shown in the figure and extend the transmitter and receiver antenna fully.

Connection to this connector

(1) When chassis power supply of engine or motor car is separate

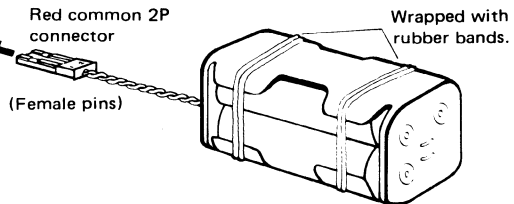

(75MHz-OPTIONAL)

(2) When motor car uses a special BEC system chassis (common power supply specifications)

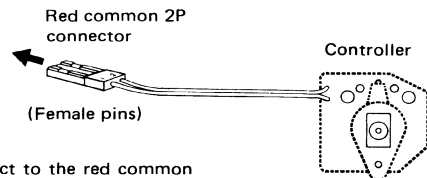

Connect to the red common 2P connector of the controller.

(3) When motor car uses an ordinary common power supply chassis

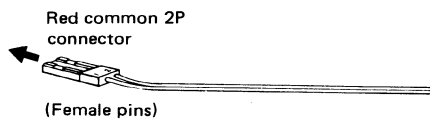

Buy the red common 2P connector from the kit manufacturer and connect to the controller.
Pin 1: Minus
Pin 2: Plus

The Futaba BEC (Battery Eliminator Circuitry) system can also use a common power supply with the conventional four penlight batteries system (separate power supply).

• A common power supply regulator and diode may also be supplied with the speed controller, depending on the vehicle kit. Since they cause a voltage drop, always remove them.

- Set the transmitter power switch to ON, then set the receiver power switch to ON. The servos stop near the neutral position. Operate the transmitter sticks and check if each servo faithfully follows operation of the sticks.
- Connect the pushrod to each servo horn, then check if the direction of travel of each servo matches the transmitter operation.
- Operate each servo over its full travel and check if the pushrod binds or is too loose. Applying unreasonable force to the servo horn will adversely affect the servo and quickly drain the battery. Be especially careful when using 8.4V.

- Always make the full stroke (including trim) of the servo horns somewhat larger than the full travel. Adjust the servo horns so that they move smoothly even when the trim lever and stick are operated simultaneously in the same direction.
- Be alert for noise. Always solder a noise killing capacitor to the running motor. If metal parts touch each other due to vibration, noise will be generated and cause the receiver servos to operate erroneously. We recommend the use of noiseless parts.
- Even though the receiver antenna wire is long, do not cut or bundle it. The range of the radiowaves will be shortened.

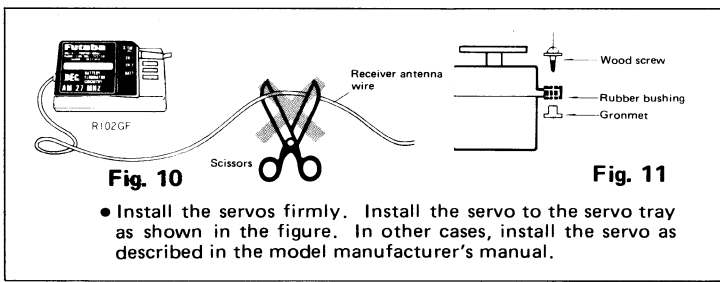

● Install the servos firmly. Install the servo to the servo tray as shown in the figure. In other cases, install the servo as described in the model manufacturer's manual.

- A spare horn is provided. Use it as required.
- Wrap the receiver in sponge rubber and wrap rubber bands around the sponge rubber. Mount the receiver so it is not exposed to vibration, does not touch the frame, and does not move.
- When the receiver is installed on a board or used where it may be splashed with mud and water, place it in a plastic bag, etc. and wrap a rubber band around the open end of the bag to waterproof and dustproof the receiver. After use, remove the receiver from the bag to prevent condensation.
- Use the rubber bands wrapped around the receiver to hold the servo and switch leads.
- After mounting is complete, recheck each part, then check the transmitting range by making the transmitter antenna as short as possible and extending the receiver antenna fully and operating the set from a distance of 20m to 30m. The movement of each servo should follow the movement of the transmitter sticks.
- The crystal can be changed from the outside of the receiver case. Always use a Futaba transmitter and receiver crystal pair as the replacement crystals.

USING THE ANTENNA FREQUENCY FLAG

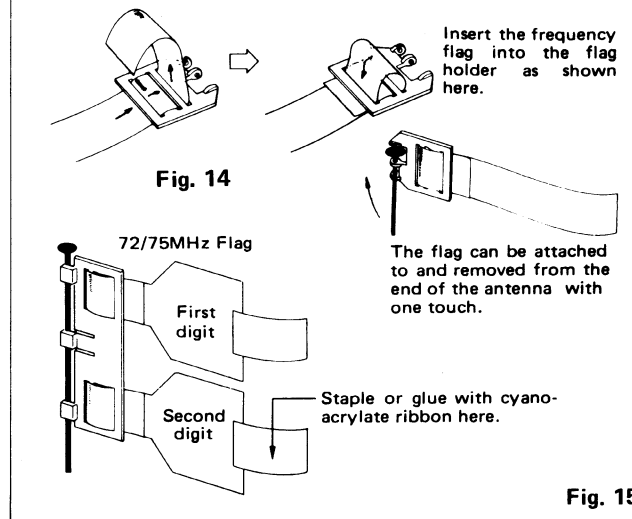

MOTOR CAR

Operation of the throttle (engine control) servo can be set as shown in this figure by ② throttle trigger operation.

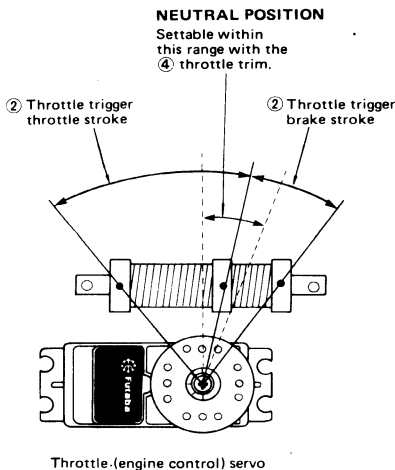

Fig. 12

- See the figure for the motor, battery, and speed controller wiring.

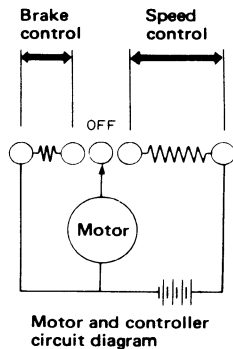

Fig. 13

- When the drive battery is also used as the receiver servo power supply with a moto-driven car, pay careful attention to the power supply polarity and voltage. With Futaba proportional R/C power supplies, red represents ⊕ and black represents ⊖.

● SPLINED HORNS

This horn permits shifting of the servo neutral position at the servo horn. Setting and shifting the neutral position

a) Angle divisions

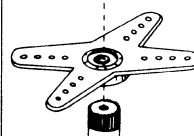

Fig. 16

- 1) The splined horn has 25 segments. The amount of change per segment is; $360 \div 25 = 14.4^\circ$
 - 2) The minimum adjustable angle is determined by the number of arms or number of the holes. For four arms, the minimum adjustable angle is: $360 \div \frac{(25 \times 4)}{\text{Number of divisions}} = 3.6^\circ$
- b) Effect

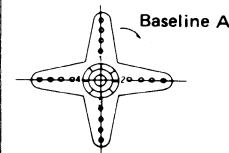

Fig. 17

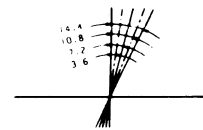

Fig. 18

To shift the holes center line to the right (clockwise) relative to baseline A, shift arm 2 to the position of arm 1 and set it to the position closest to baseline A. [Example] For a four arm horn, the angular shift per segment is 14.4° . The shift to the right is $90^\circ - (14.4 \times 6) = 3.6^\circ$. To shift by the same angle in the opposite direction, use the opposite arm number.

For a six arm horn, turn the arm counterclockwise and set arm 2 to the position of arm 1. The adjustable angle is $60^\circ - (14.4 \times 4) = 2.4^\circ$. Arm 3 shift 4.8° to the right, arm 6 shifts 2.4° to the left, and arm 4 shifts 7.2° to the right and left.

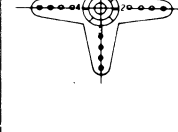
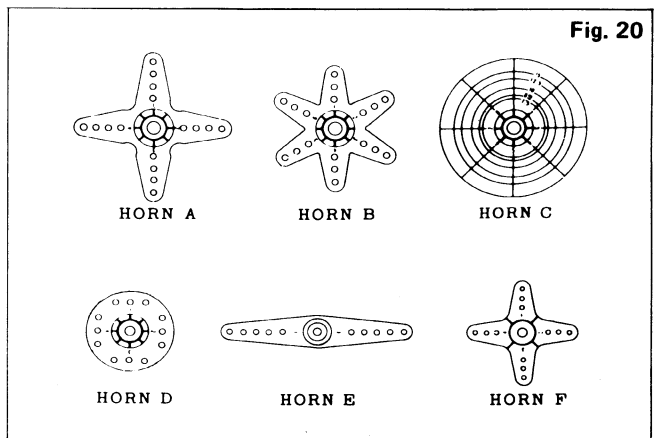

Fig. 19



GUARANTEE

Your NEW FUTABA Digital Proportional R/C system is guaranteed against defects in workmanship and material for 180 days from the date of purchase when the attached registration card is returned to us within ten days of purchase.

This Guarantee is null and void if the R/C system has been improperly handled, damaged in a crash, or tampered with and does not cover the replacement of plastic housings or electronic components damaged due to the use of improper voltages.

When service is required, please take your equipment to your local authorized service station or ship it directly to us. All postage, shipping, and insurance charges must be paid by the user.

REPAIR SERVICE

- When requesting repair of trouble that has occurred suddenly or from long use, describe the trouble symptoms in as much detail as possible. This will facilitate detection of the trouble point and shorten the repair period greatly.
- Defects caused by faulty materials of workmanship will be corrected free of charge.
- This limited warranty is null and void if the set has been tampered with or disassembled. Refer to warranty statement for details.

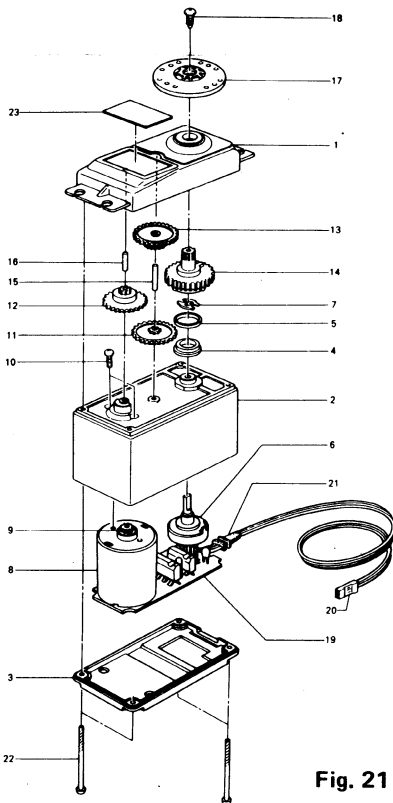

Fig. 21

FP-S148

No.	Part name	Part No.
1.	Upper case	FCS-48
2.	Middle case	FCS-48
3.	Bottom case	FCS-48
4.	Metal bearing	S04137
5.	Metal bearing	S04136
6.	Potentiometer	I39668
7.	Potentiometer drive plate	S02753
8.	Motor	S91239
9.	Motor pinion	S02461
10.	Screw	J50002
11.	1st gear	FGS-48
12.	2nd gear	FGS-48
13.	3rd gear	FGS-48
14.	Final gear	FGS-48
15.	Intermediate shaft	S02495
16.	2nd shaft	S02494
17.	Servo horn D	FSH-6W
18.	Binding head tapping screw 2.6 x 8	FSH-4I
19.	Printed wiring board S148	AS1157
20.	3PB-WRB300G	AT2453
21.	w. gum bush	S90045
22.	Pan head truss screw	S50360
23.	Nameplate S148	S60099

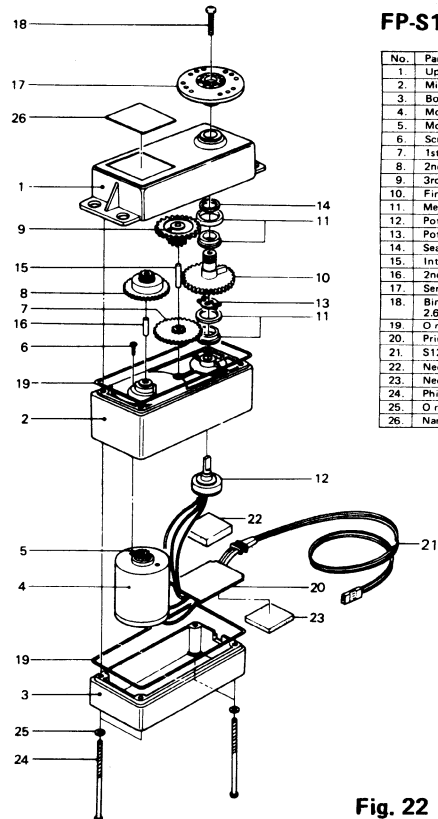

Fig. 22

FP-S129

No.	Part name	Part No.
1.	Upper case	
2.	Middle case	FCS-29
3.	Bottom case	
4.	Motor	S91212
5.	Motor pinion	S05402
6.	Screw 2x3	J50002
7.	1st gear	FGS-29
8.	2nd gear	FGS-29
9.	3rd gear	FGS-29
10.	Final gear	FGS-29
11.	Metal bearing	S04134
12.	Potentiometer	I39995
13.	Potentiometer drive plate	S02753
14.	Seal ring	S90415
15.	Intermediate shaft	S04287
16.	2nd shaft	S01351
17.	Servo horn D	FSH-6W
18.	Binding head tapping screw 2.6x8	FSH-4I
19.	O ring 32.6φ	S90420
20.	Printed wiring board	AS1206
21.	S129...3PB-WRB300	FPC-8M
22.	Neosul sponge 5x15x15	S90236
23.	Neosul sponge 3x15x7	S90333
24.	Phillips pan head screw	J50400
25.	O ring 1.6φ	S90410
26.	Name plate	S80702



FUTABA CORPORATION OF AMERICA
 555 West Victoria Street, Compton, Calif. 90220, U.S.A.
 Phone: 213 537 9610, Telex: 23 0691227, Facsimile: 213 637 8529

FUTABA CORPORATION
 Tokyo Office: Inagaki Bldg. 1-21-3, Kanda Suda-cho, Chiyoda-ku, Tokyo 101, Japan
 Phone: (03) 255 6811, Facsimile: (03) 255 6880