

566B SUPER TRAIL

INSTRUCTION AND ASSEMBLY MANUAL

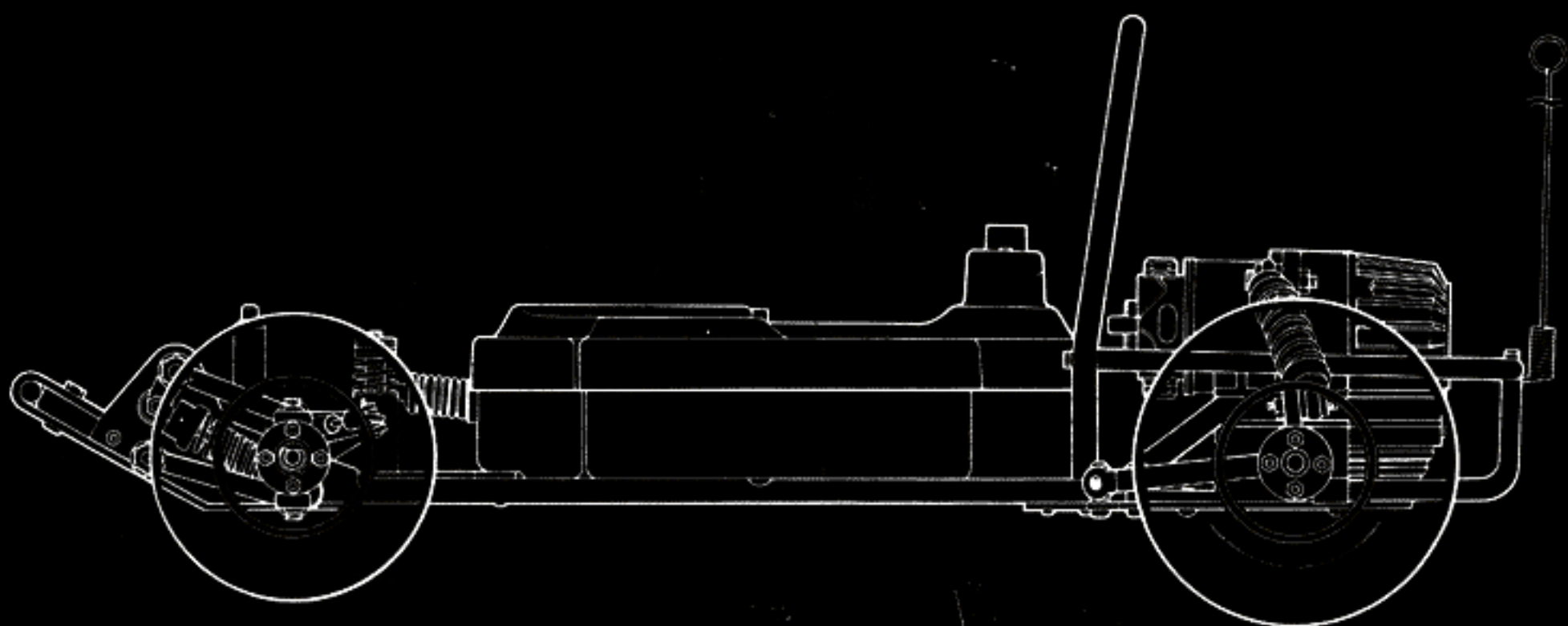

2 CHANNEL, PROPORTIONAL RADIO CONTROL SYSTEM REQUIRED

Dual stick (shown) or steering wheel transmitter, receiver and two servos.

Battery case

7.2v/1200mAh NiCad pack

4-AA cells

Mabuchi RS540 (stock)

AYK GZ480 (Optional)

ADDITIONAL TOOLS REQUIRED

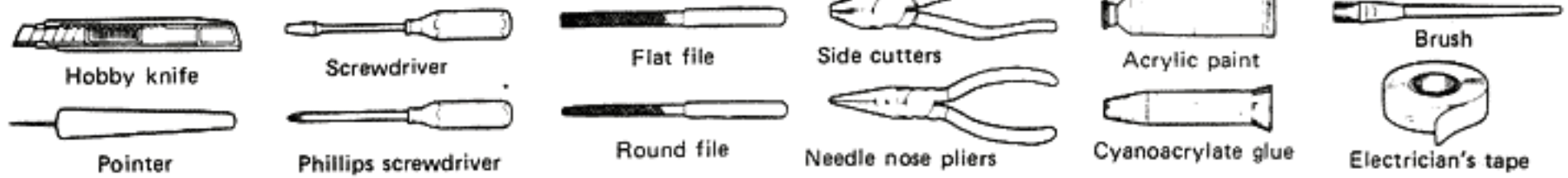

CONTENTS OF THE KIT

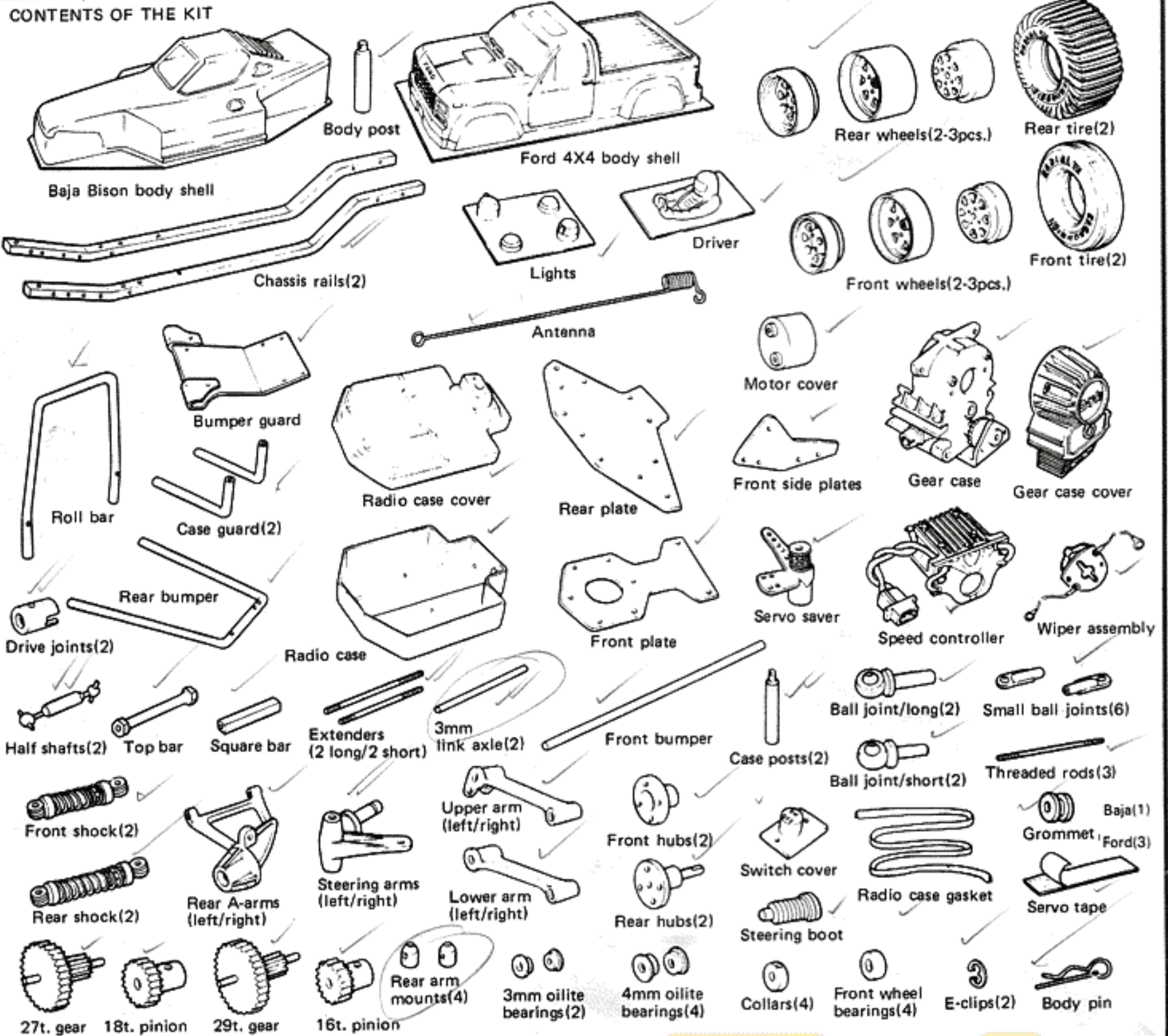

CAP SCREWS



PHILLIPS SCREWS

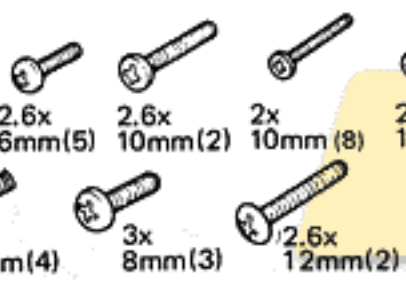

LOCKNUTS



MACHINE NUTS



SET SCREWS

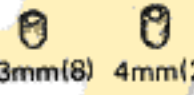

WASHERS

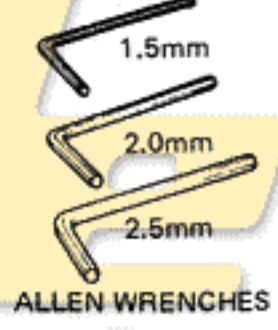
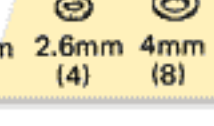

1 MOTOR DUST COVER

Protect the brush cap bearings and motor brushes with the rubber cover

Add silicone seal on openings for additional waterproofing

Mabuchi RS540 or GZ480

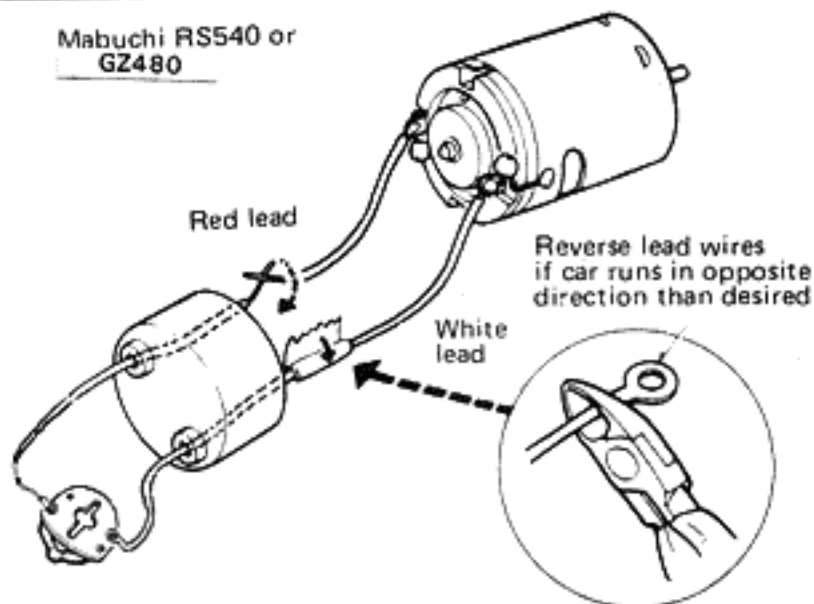

CHECK THE GEAR BOX ONCE MORE!

The gear box is temporarily assembled, so that please check the assembling referring to the following drawing

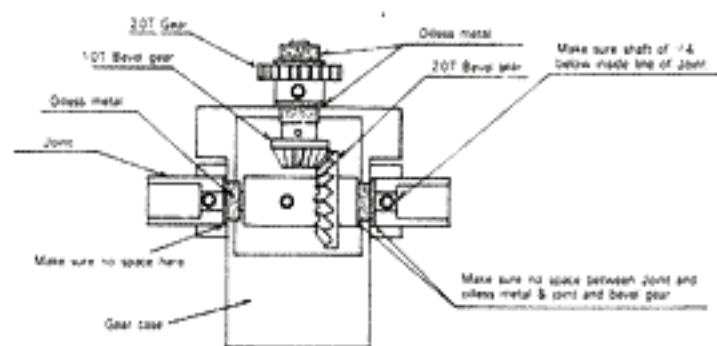

1. As shown in the right side of the above drawing assemble joint, oilless metal and 20T bevel gear tightly.
2. As shown in the left side of the above drawing, assemble joint to oilless metal and gear case tightly. After the above 1 & 2 assembling work, move the 20T bevel gear to the right and make sure no loose point of the both sides of joint.
3. The 10T bevel gear should be adjusted tight with 1/4 hollow of the 20T gear.
4. Tighten throttle 1/4 hollow enough and use locking screw.
5. In case of looseness of screws in running, stop immediately and check the above points.

- ⊗ Do not tighten too much and leave some looseness in absorber assembly
- * Each assembly using screw(s) should be done by locking type

2 GEAR BOX

- 2.6x5mm (2) cap screws
- 3mm oilite bearings (2)

- 2.6x8mm (2) cap screws
- 3mm set screw

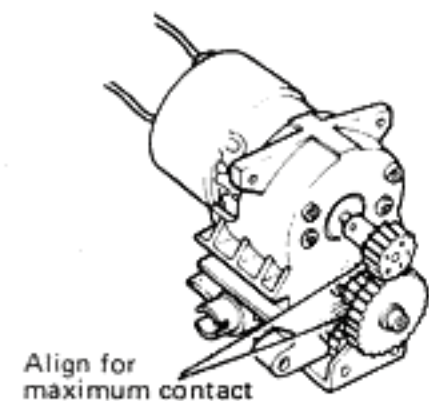

For High Speed : 18T pinion gear & 27T gear
For Low Speed : 16T pinion gear & 29T gear

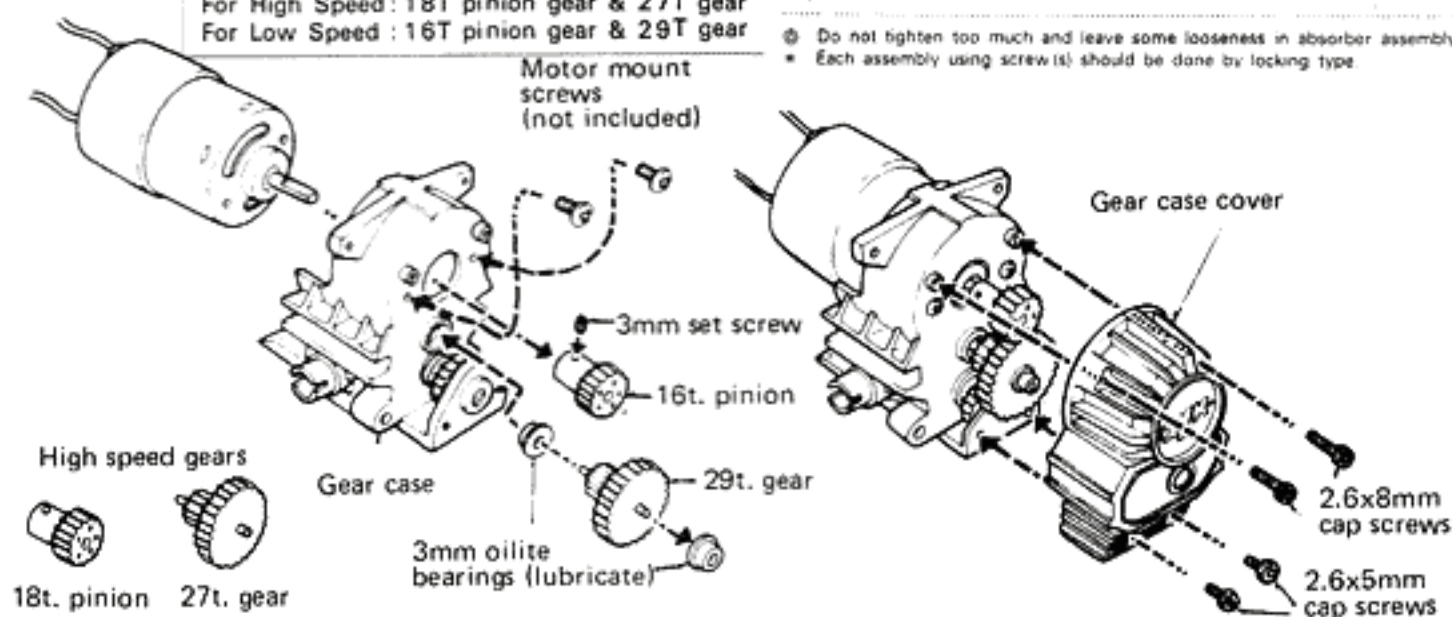

3 CHASSIS RAILS

- 2.6x10mm cap screws (4)

- 2.6x6mm phillips screws (4)

Attach chassis rails to the gear case using cap screws and holes provided in case sides

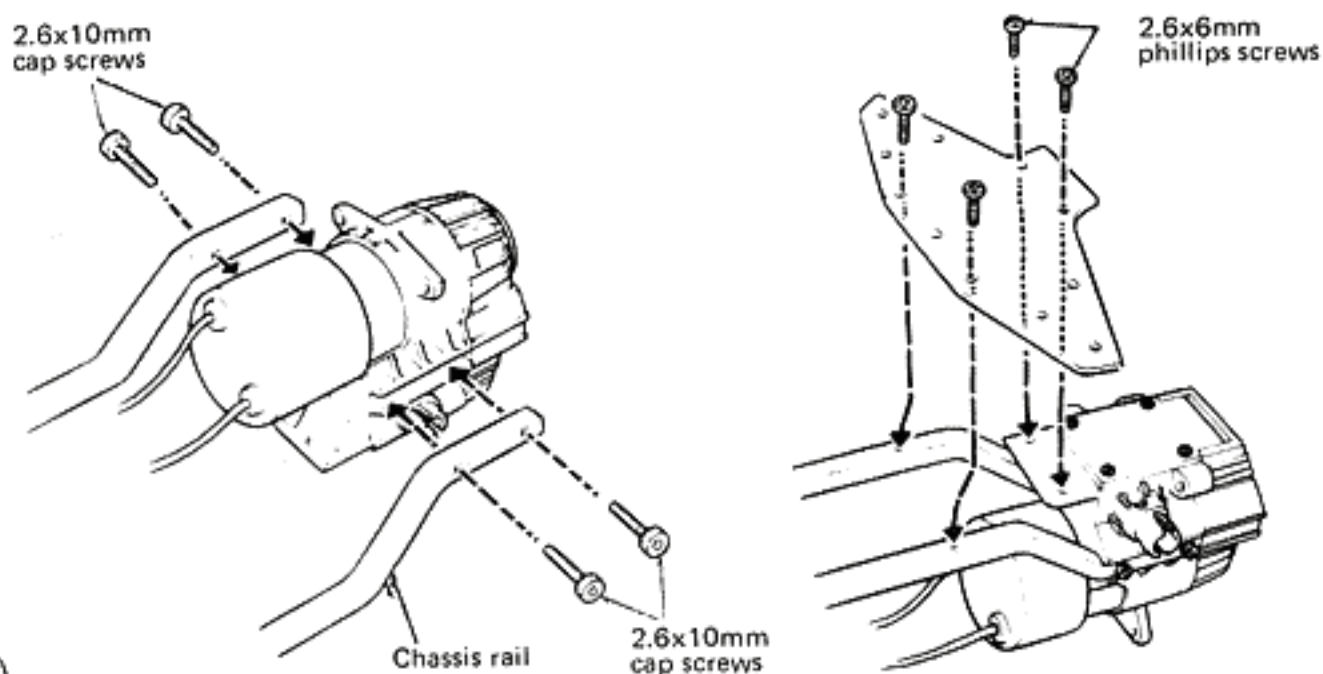

4 FRONT END

- 2x12mm phillips screws (4)

- 2.6x12mm phillips screws (2)

- 2.6mm machine nut (2)

- 2.6x8mm cap screws (4)

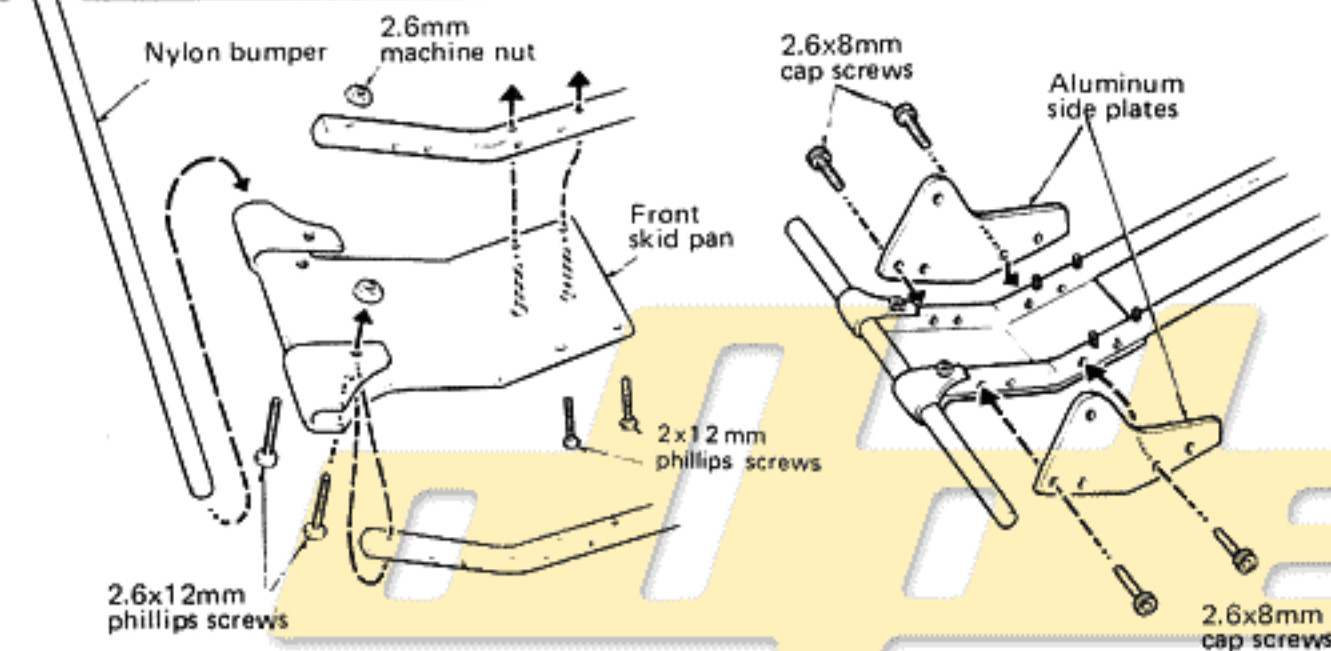

5 FRONT SUSPENSION

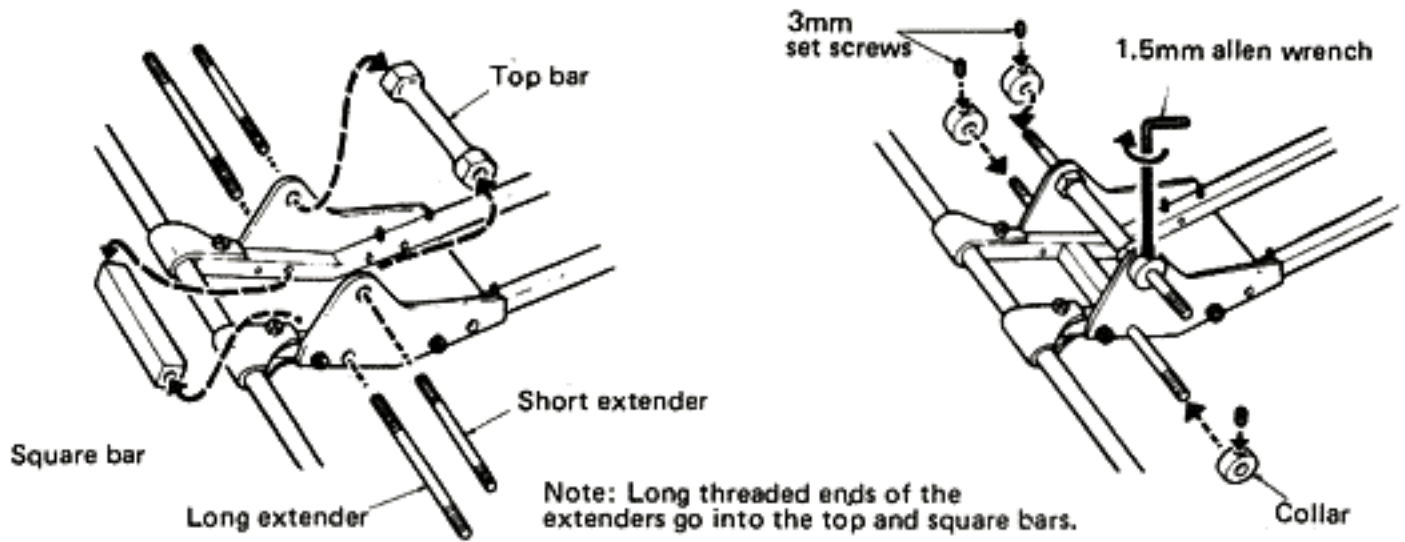
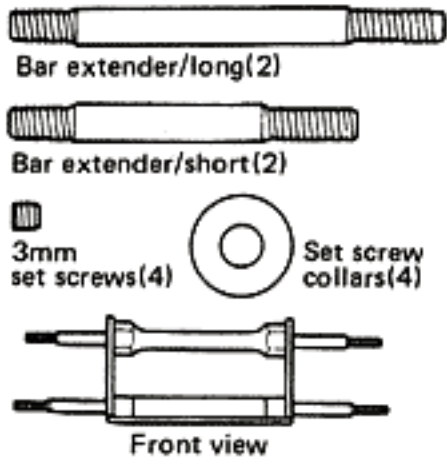

6 TRAILING ARM ASSEMBLY

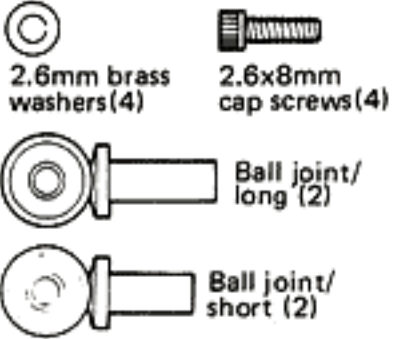

LOWER ARM/RIGHT

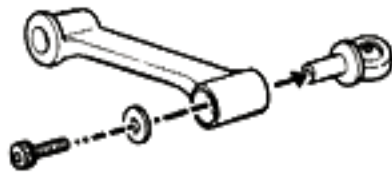

UPPER ARM/RIGHT

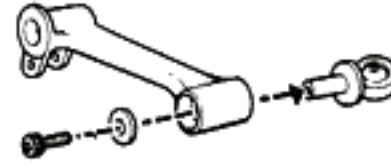

LOWER ARM/LEFT

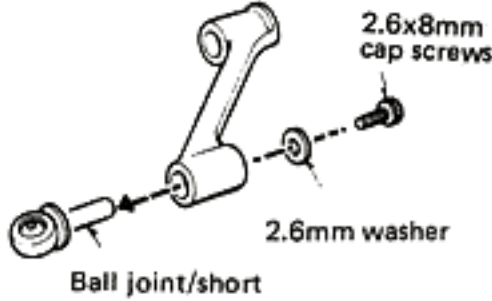

UPPER ARM/LEFT

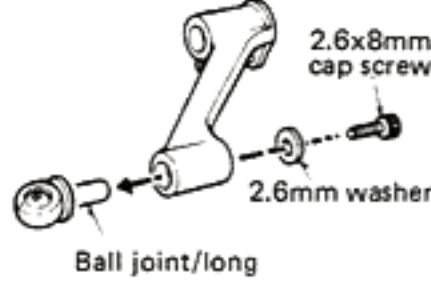

7

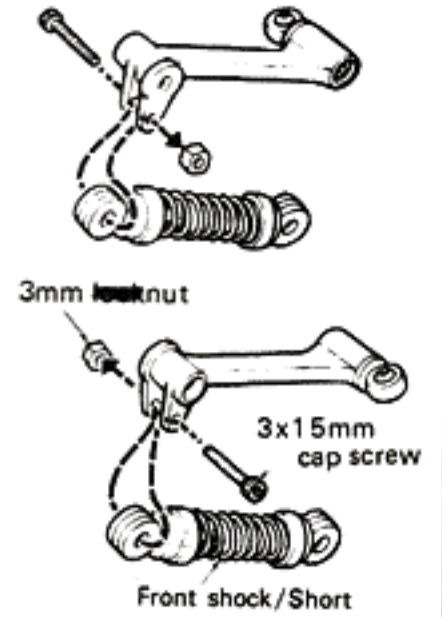

7 SHOCK MOUNTS

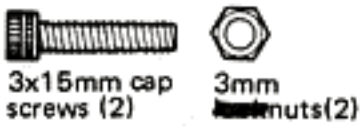

8 SHOCK ABSORBER INSTALLATION

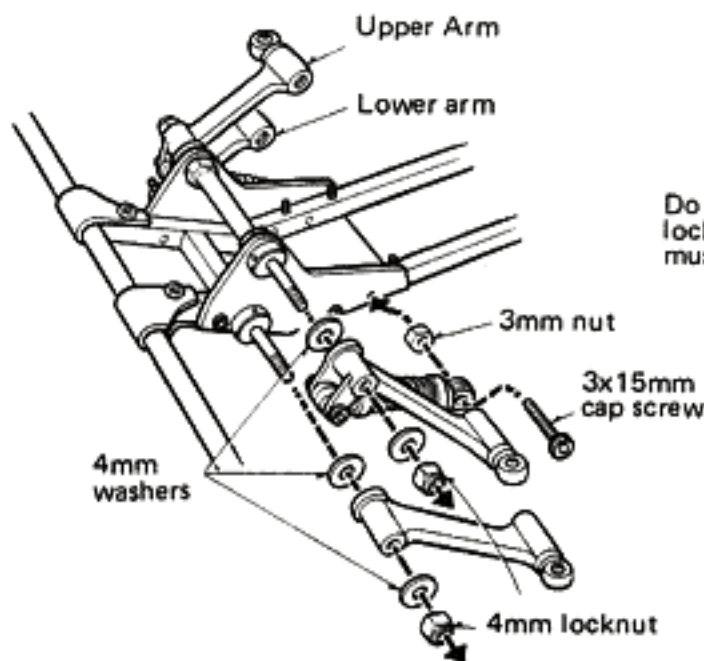
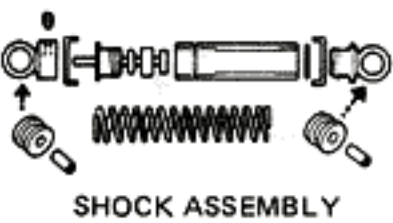
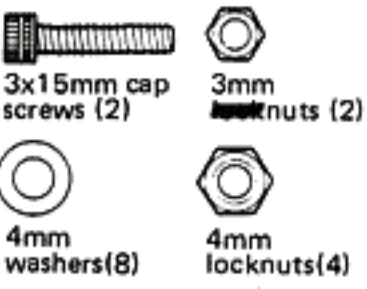

Do not overtighten locknuts. Arms must move freely.

Use 3mm nut to lock 3x15mm cap screw to side plate.

9 STEERING ASSEMBLY

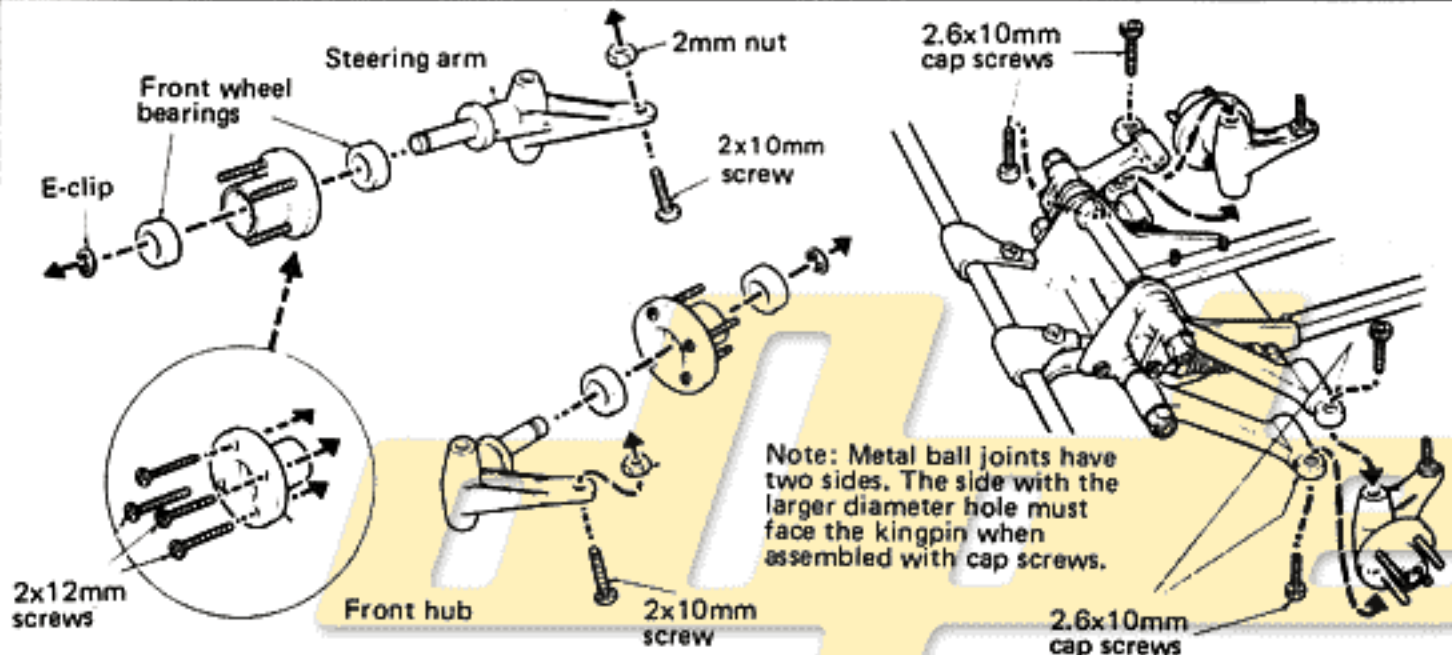
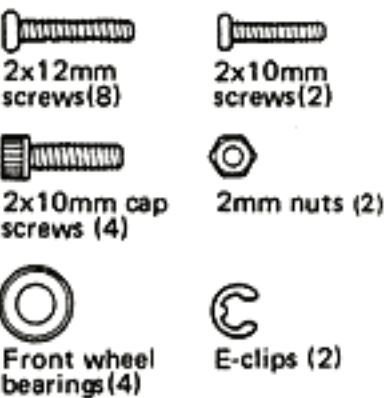

10 SERVO SAVER

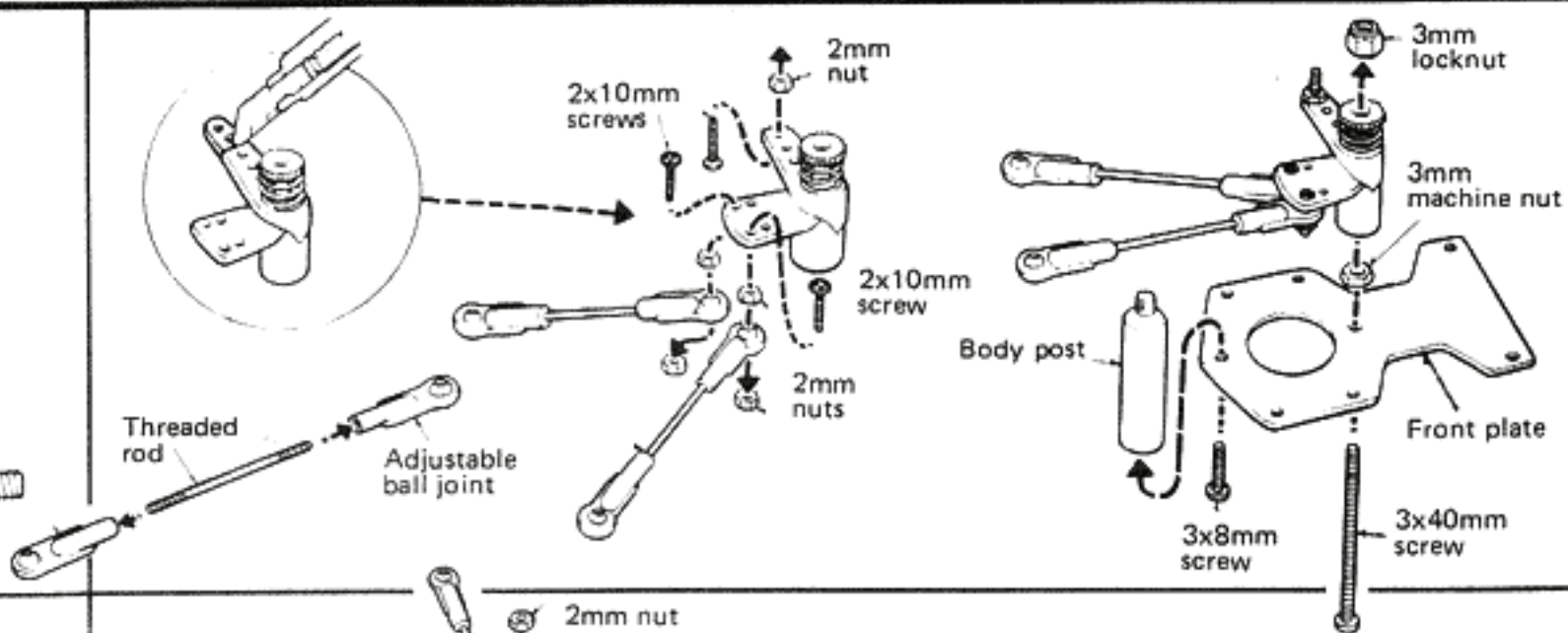
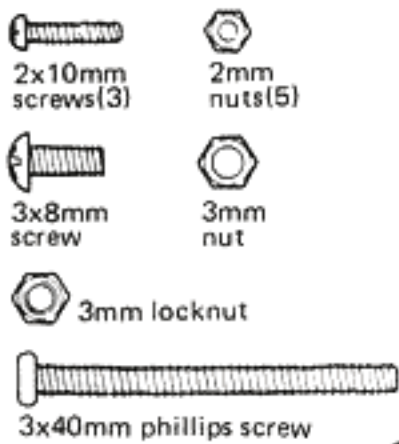

11 FRONT PLATE INSTALLATION

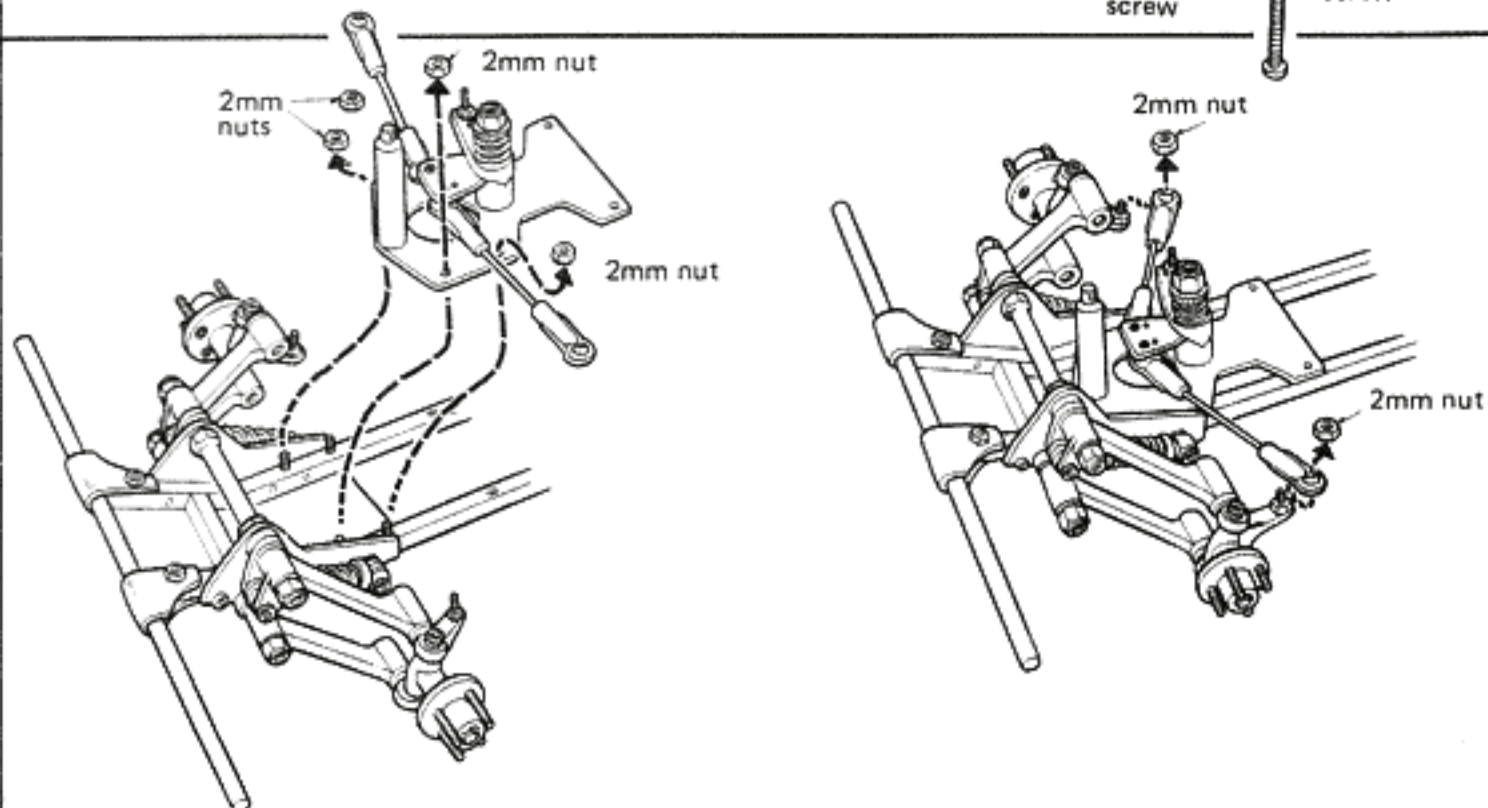
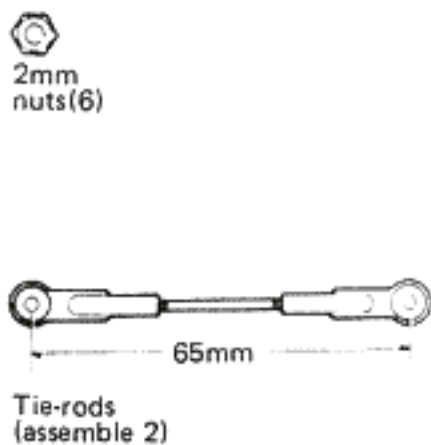

12 REAR TRAILING LINK

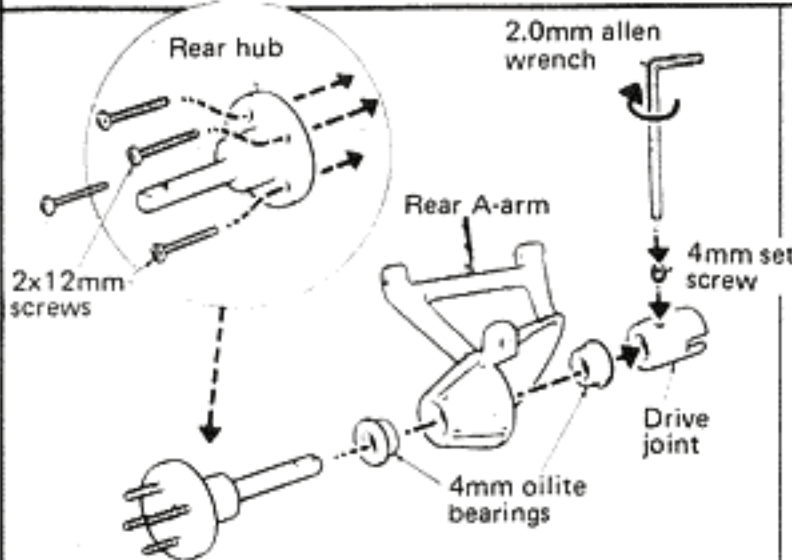
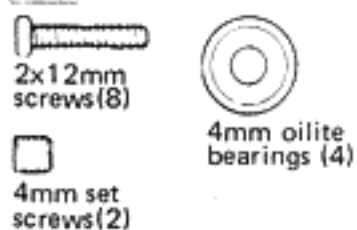

13 TRAILING LINK INSTALLATION

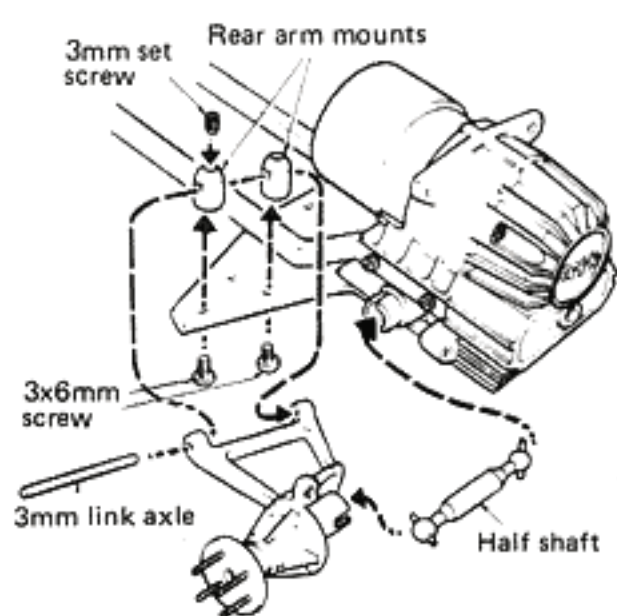
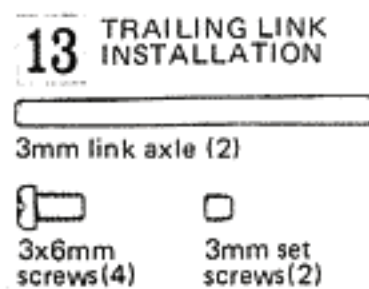

14 REAR SHOCK INSTALLATION

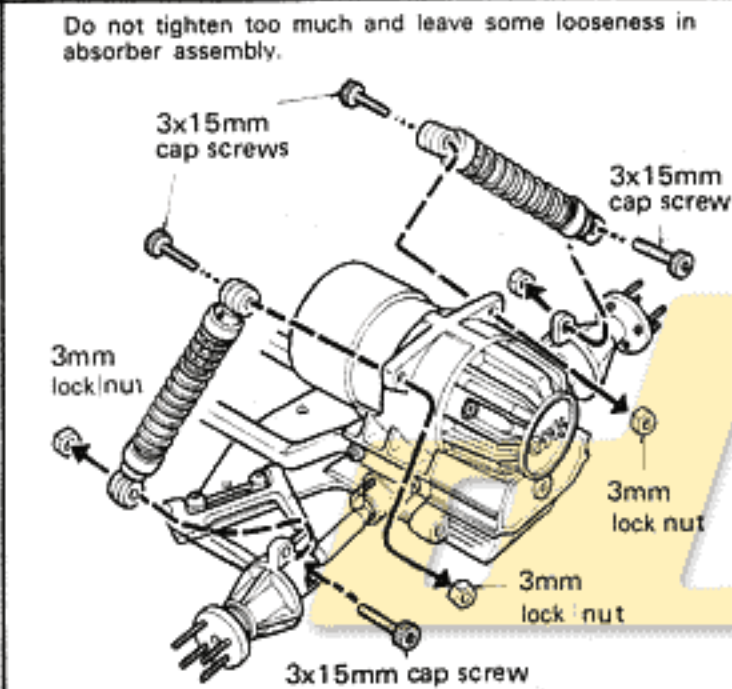
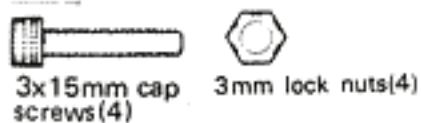

15 ROLL CAGE AND CASE GUARDS

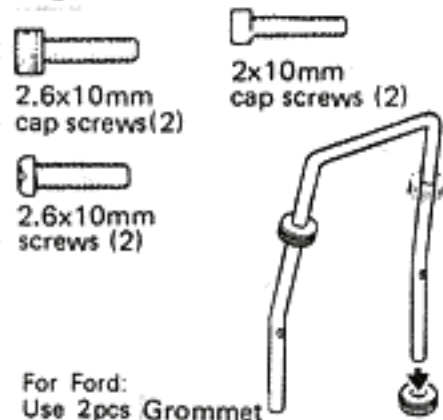

15

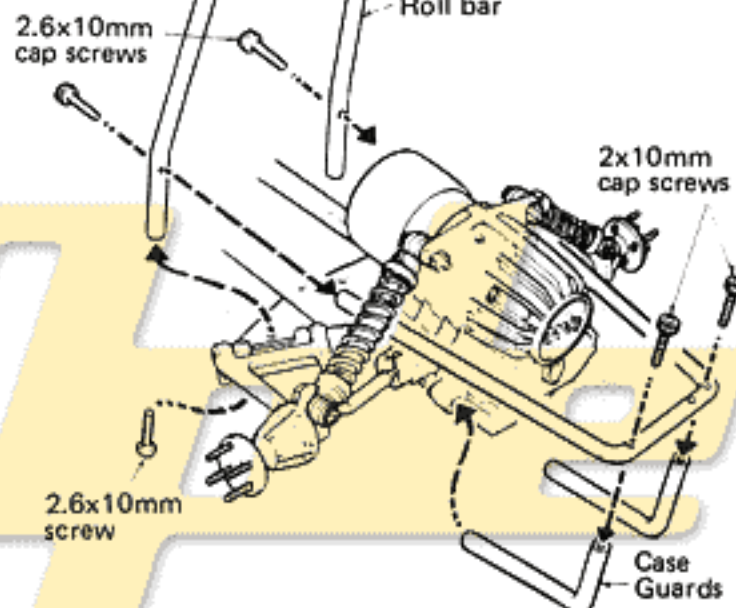

16 RADIO CASE ASSEMBLY

17 RADIO CASE MOUNTING

- 2x12mm screws(2)
- 2mm nuts(2)
- 3x8mm screws(2)
- 2mm washer (2)
- 2.6x6mm screw
- 2.6mm nut

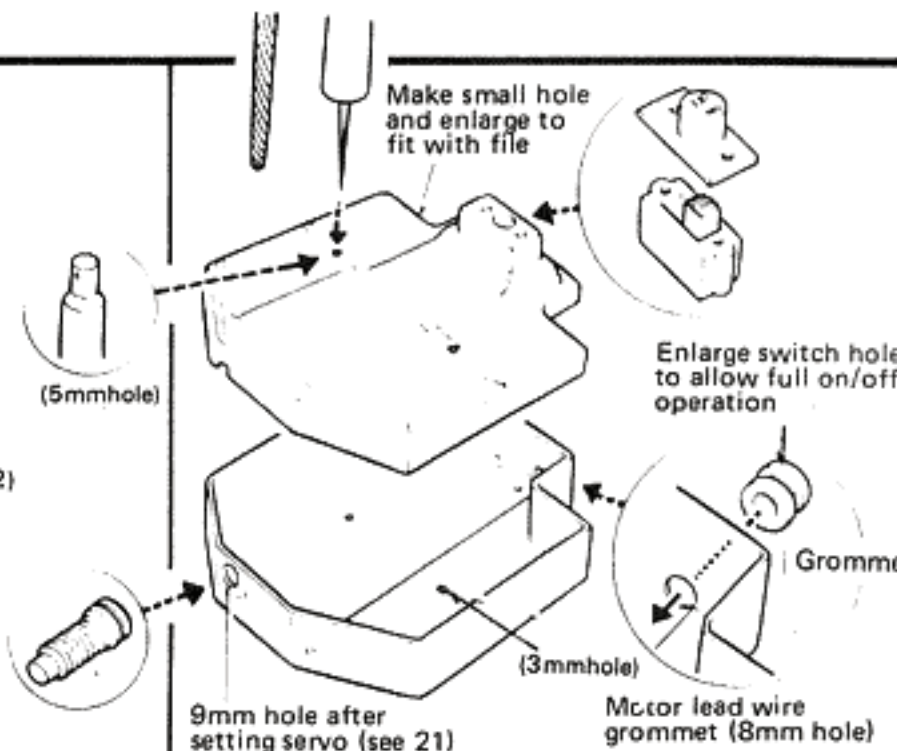

17

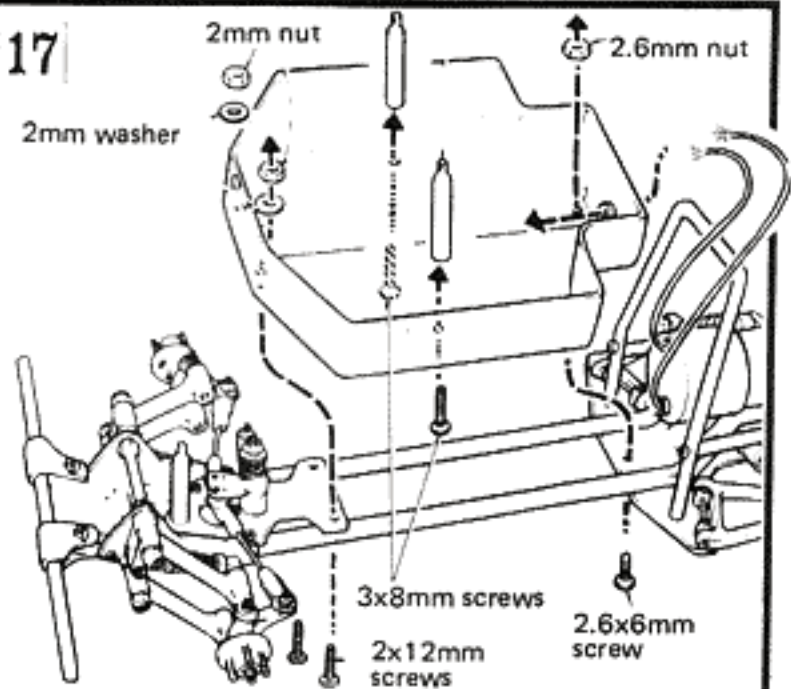

18 RADIO SYSTEM CHECK OUT

All functions should be tested for proper operation prior to installation

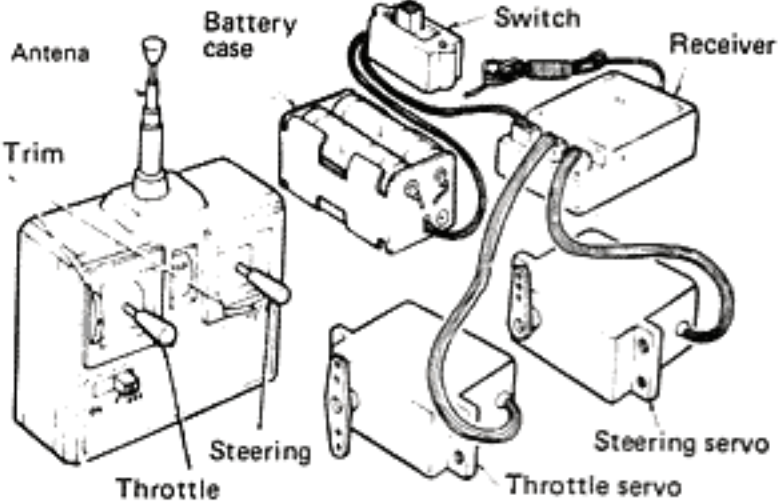

Install batteries in both transmitter and receiver cases

Check that the appropriate servo is actuated by your steering and throttle controls

Make sure both servos center at neutral position

19 SPEED CONTROL MOUNTING

Modify servo arm as shown

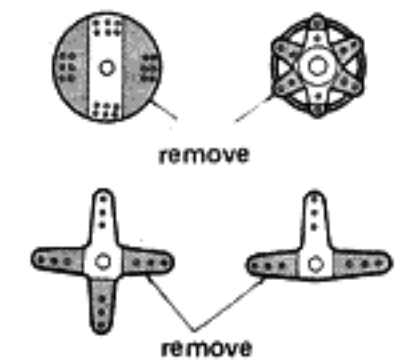

- 2x6mm self-tapping screws(2)

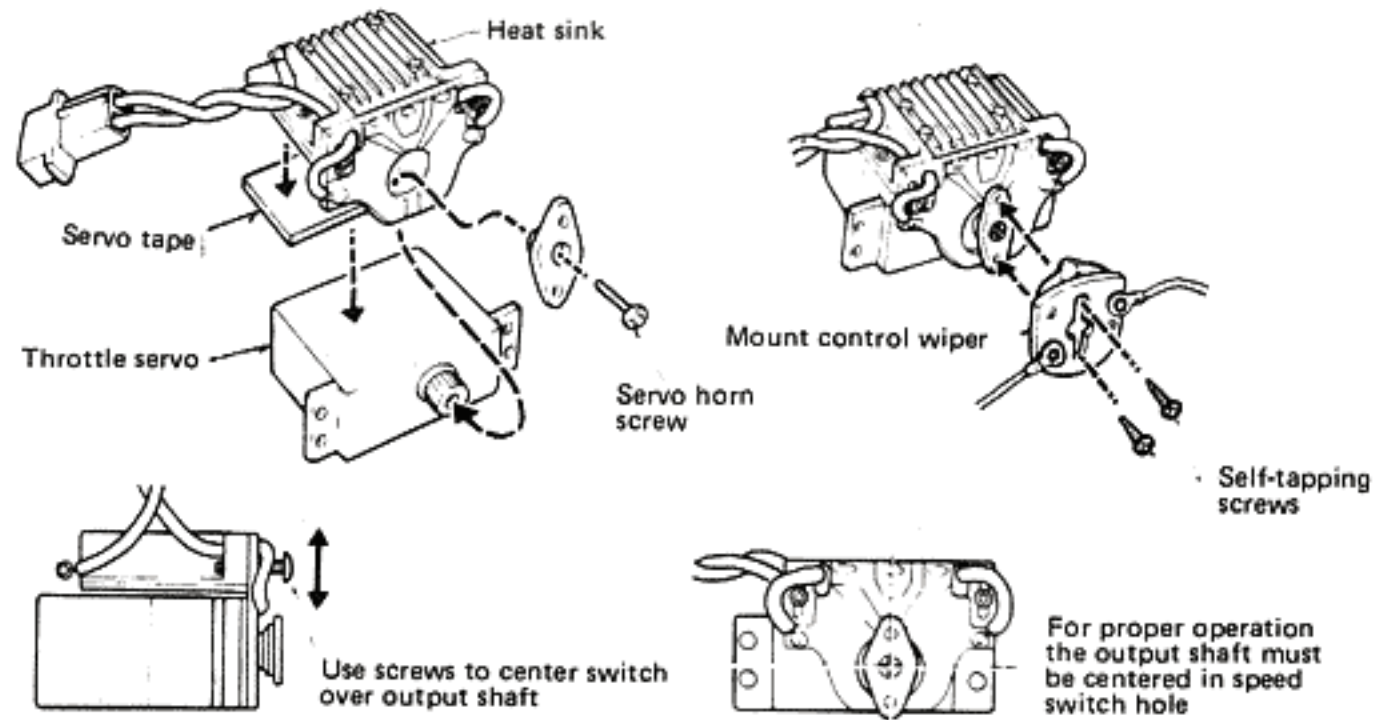

20 STEERING SERVO AND RECEIVER MOUNTING

Add layers of servo tape to clear wiper arm

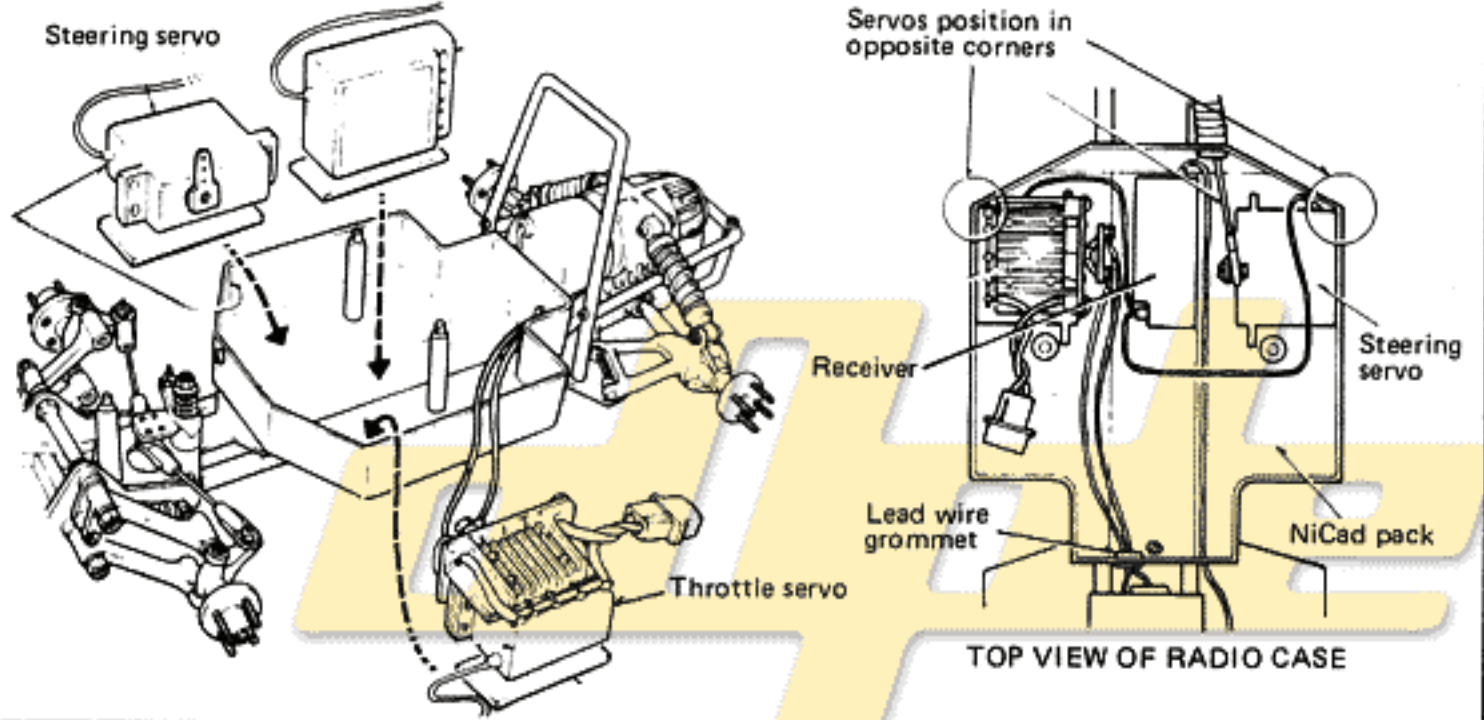
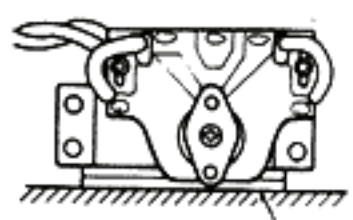

21 STEERING LINKAGE

2x10mm screw
2mm nuts(2)

2mm washer

Threaded rods(3)

Adjustable ball joint

Steering boot

Snip off nipple

Drill 9mm hole according to servo height

Bend tie-rod to match servo

2mm nut

Brass ball

2mm washer

2x10mm screw

2mm nut

Check screws for clearance

Switch screws of proportional Radio Control

Whip antenna

2x10mm cap screw

2mm nut

Switch cover

Switch

Check on/off positions

Body pins

Use silicone seal to glue radio case gasket in place.

Body pin (2)

7.2v/1200mAH battery pack

Notch box lid to clear boot

Snap adjustable ball joint together

Drill 9mm hole according to servo height

Bend tie-rod to match servo

2mm nut

Brass ball

2mm washer

2x10mm screw

2mm nut

Check screws for clearance

Switch screws of proportional Radio Control

Whip antenna

2x10mm cap screw

2mm nut

Switch cover

Switch

Check on/off positions

Body pins

Use silicone seal to glue radio case gasket in place.

Body pin (2)

7.2v/1200mAH battery pack

22 MOUNT ANTENNA

2x10mm cap screw
2mm nut

23 DUST SEALING

24 ATTACH COVER

24

7.2v/1200mAH battery pack

6

25 TIRE ASSEMBLY

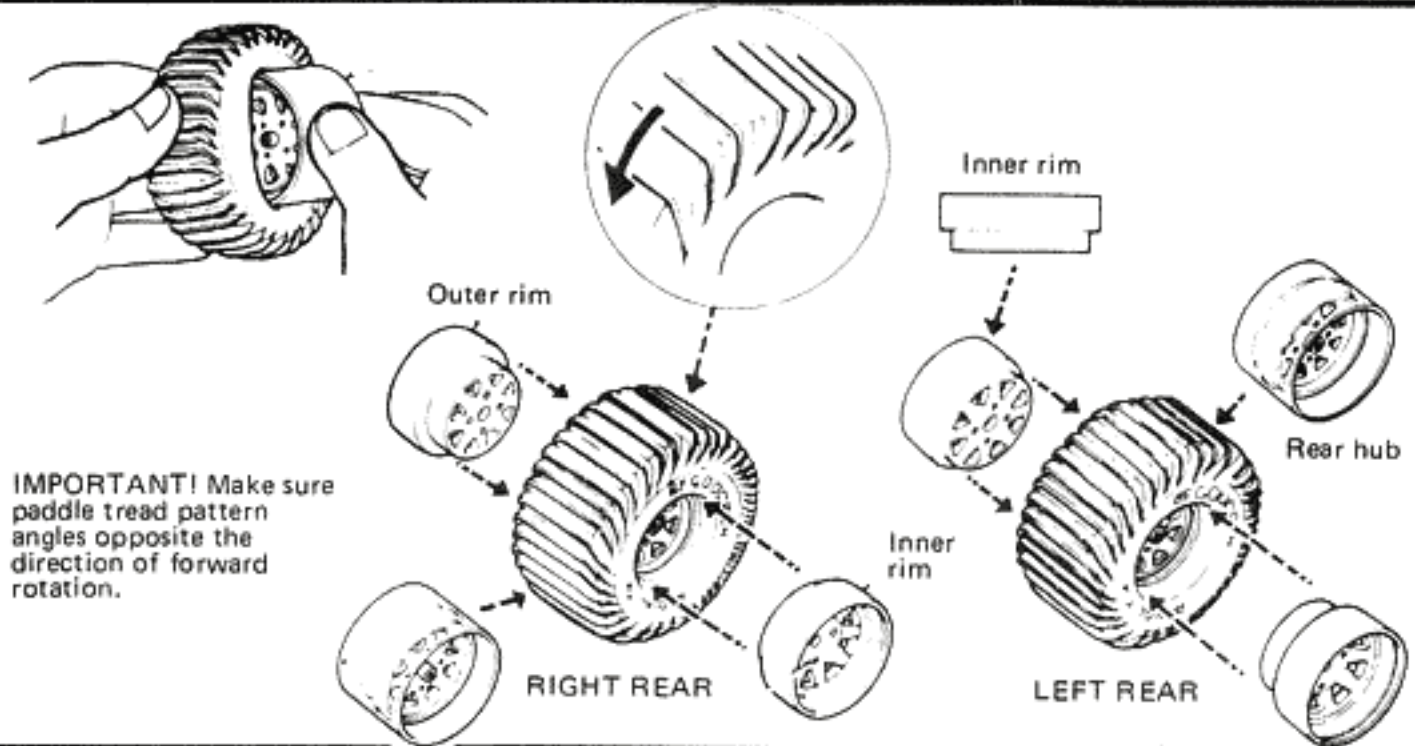
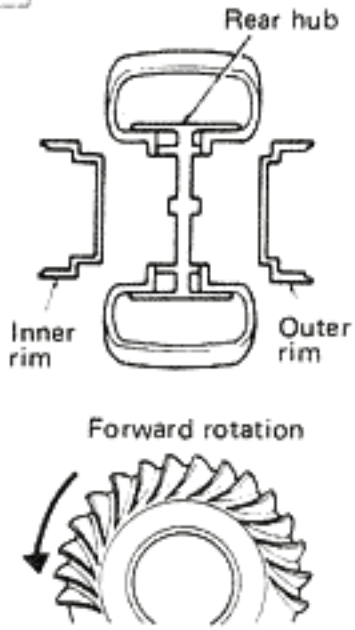

26 WHEEL MOUNTING

2mm machine nuts (16)

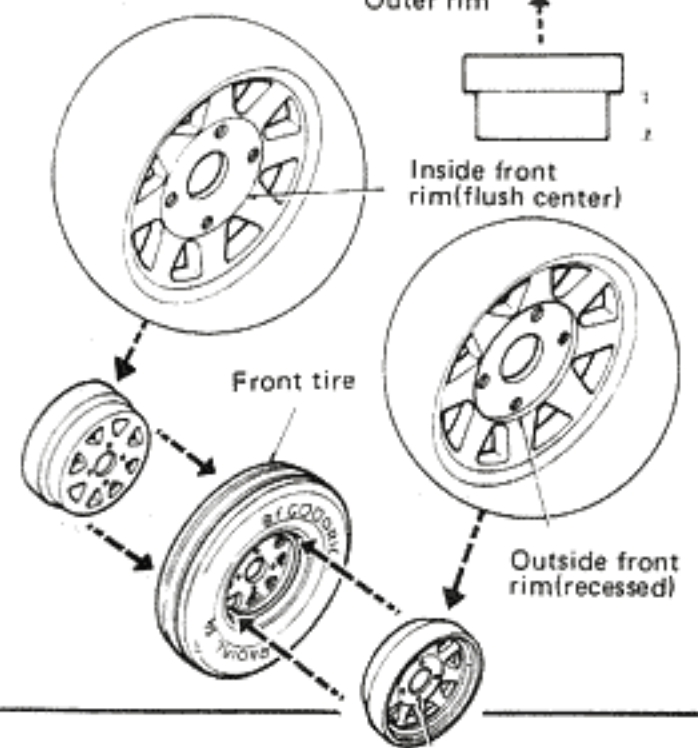
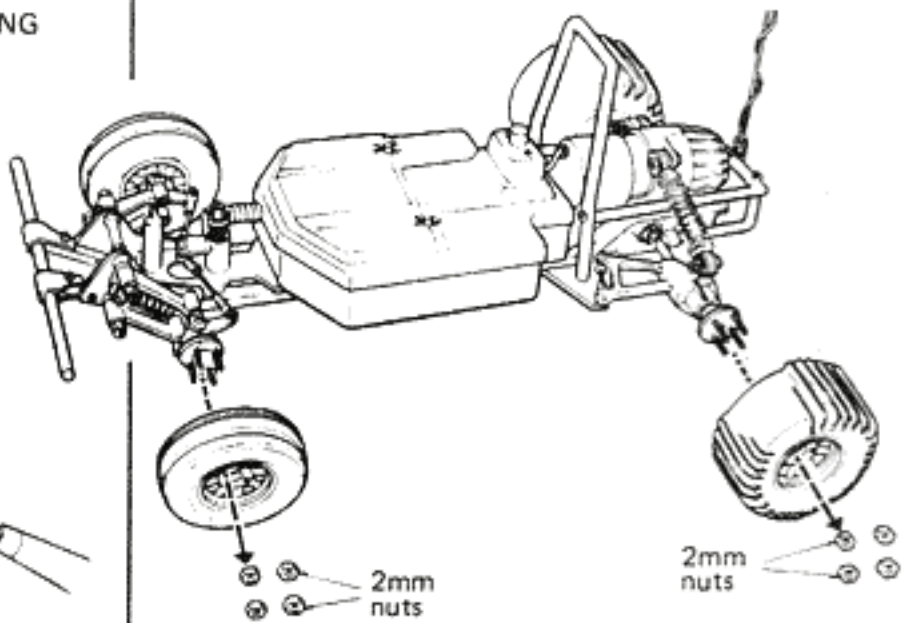
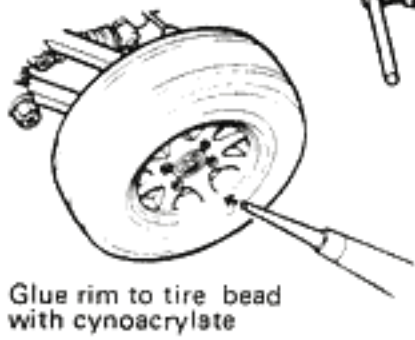

27 STAGE TUNING

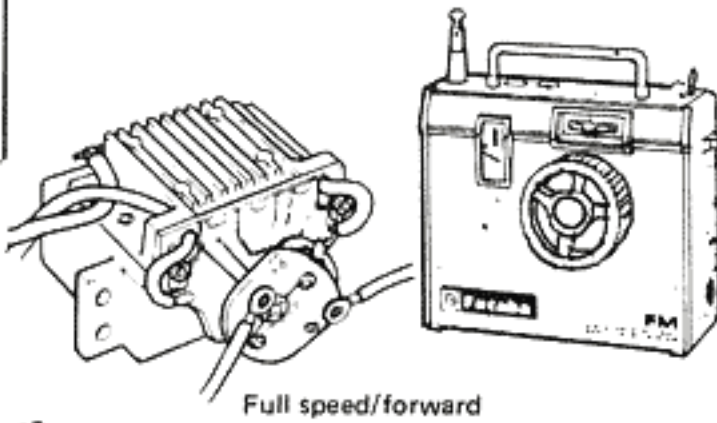
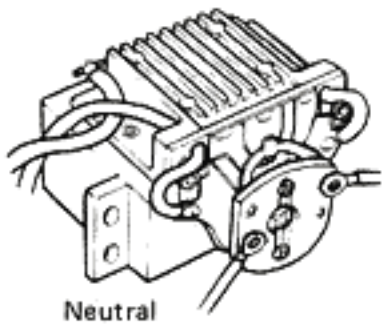

1. Pull up antenna. 2. Switch on transmitter. 3. Switch on receiver. 4. Check transmitter steering control for correct left/right and centering response. 5. Check throttle control and throttle servo for forward/reverse response. 6. With car placed on block allow to run at reduced speed for several minutes.

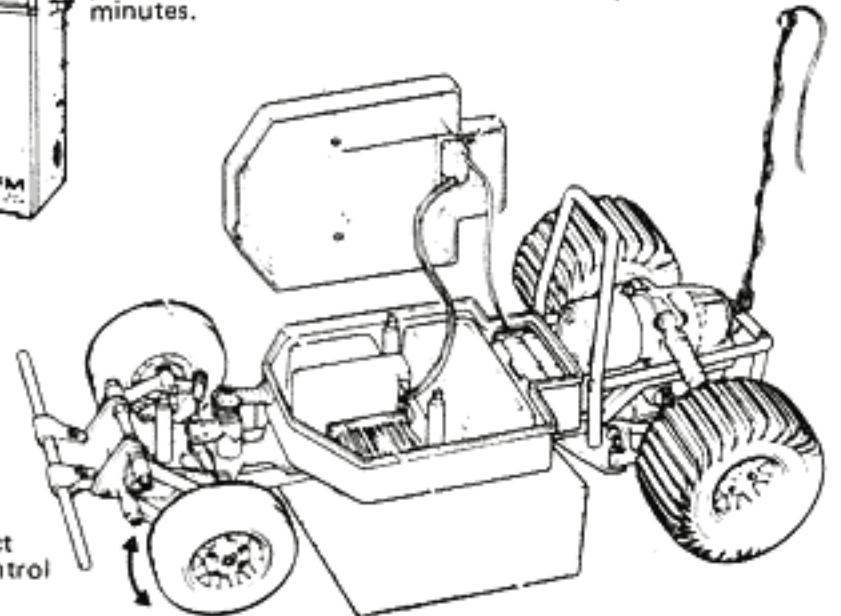
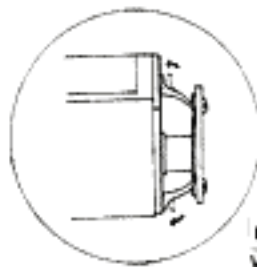
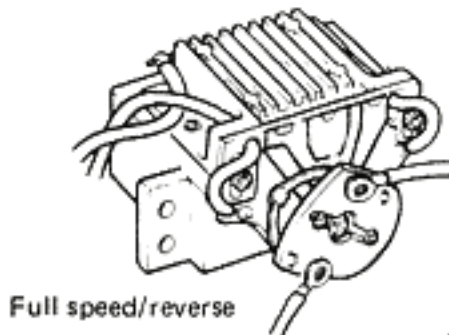

28 FRONT END ALIGNMENT

Use adjustable ball joints to set toe-in.

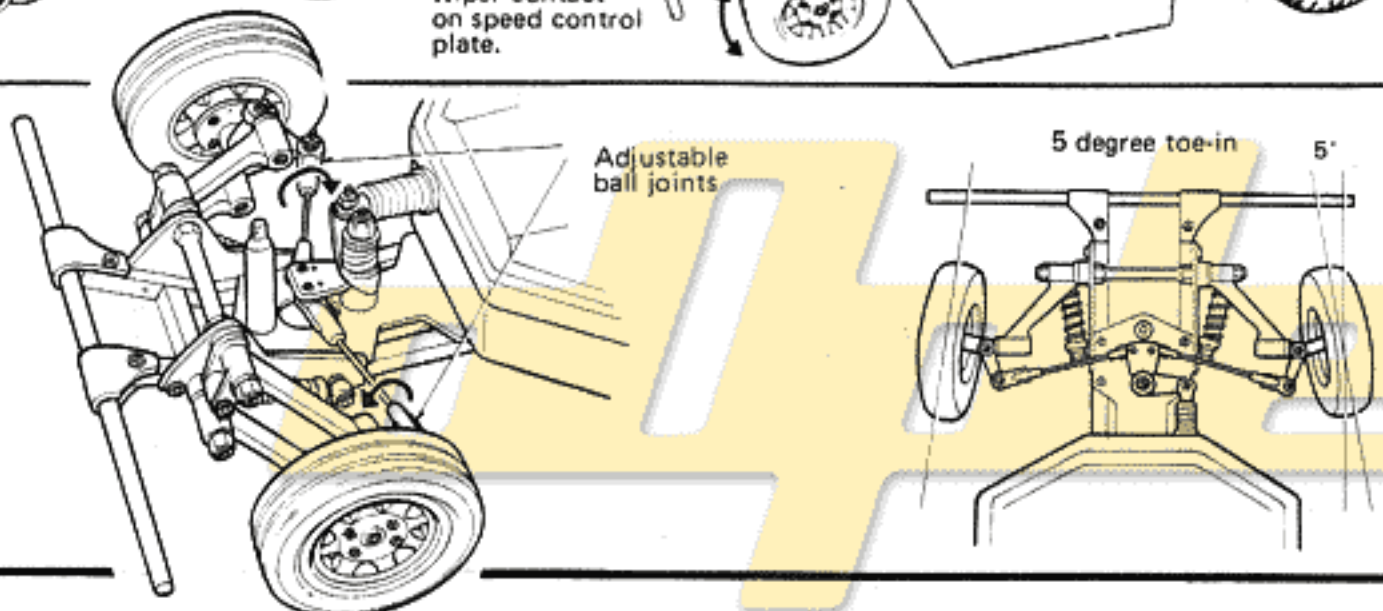

29 TRIMMING THE BODY



Roll cage opening for Ford pickup truck

Bodies can be trimmed with scissors or by scoring along trim lines with an Xacto knife.

After scoring all trim lines flex the body back and forth and it will break cleanly along the lines.

Use 180 grit sandpaper to finish up edges.

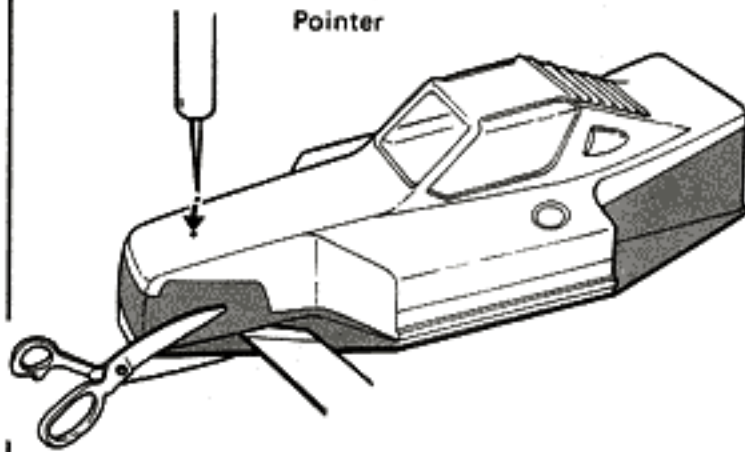

Pointer

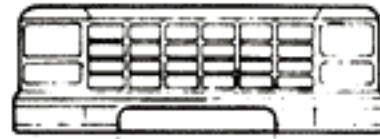
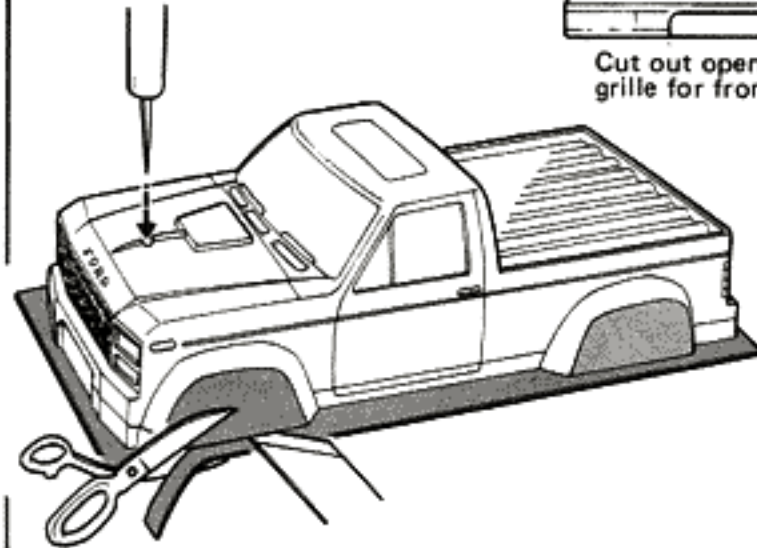

Cut out opening in lower grille for front bumper

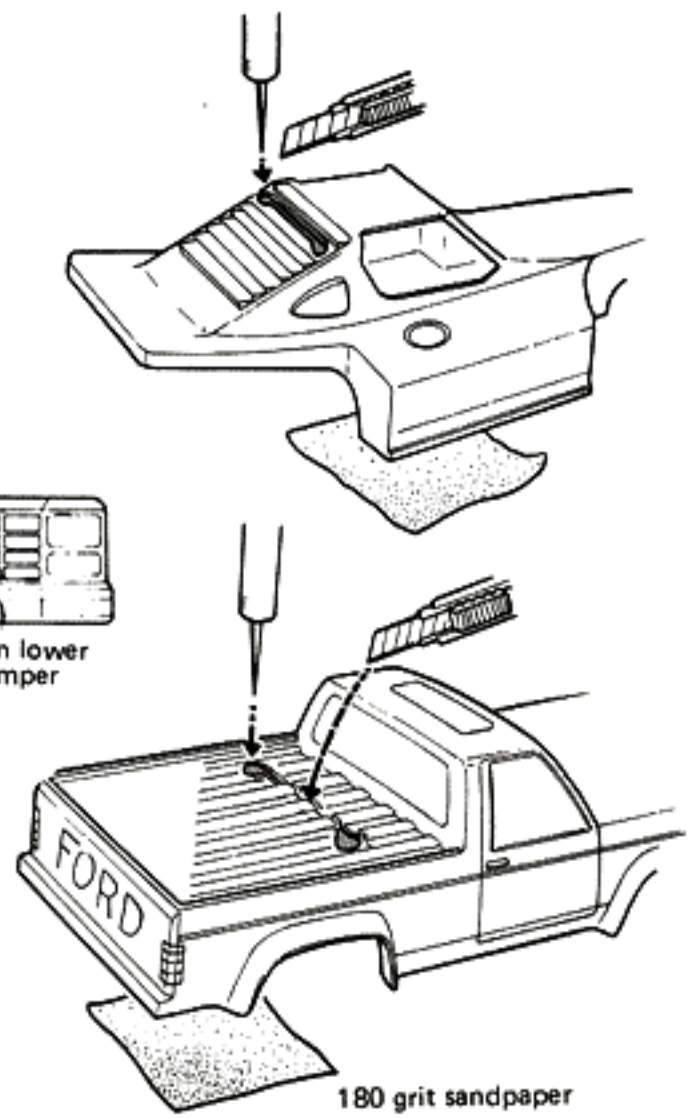

180 grit sandpaper

30 PAINTING THE BODY

Several kinds of paint will adhere well to the clear polycarbonate body without weakening it.

Avoid spray lacquers which can warp and damage the plastic.

Recommended paints include Parma and MRP/Hobby Nox (which must be airbrushed), Speedy Dry Rustoleum and artist's acrylics like BoLink's Mr. Concours brand.

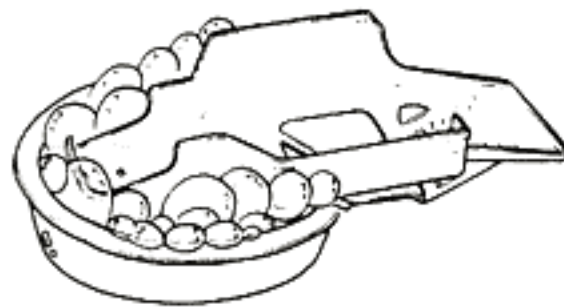

Wash thoroughly in warm, soapy water.

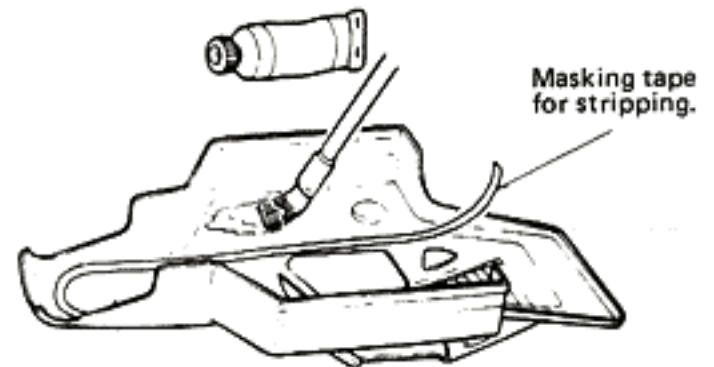

Masking tape for stripping.

Acrylics are easiest because they thin with water and can be brushed on.

31 LIGHTS AND MOUNTING

Trim light parts from the vacuum-formed sheet. Paint back half and glue on lens with cyanoacrylate.

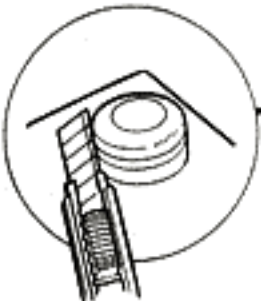

2x6mm self-tapping screws(2)



Body pin

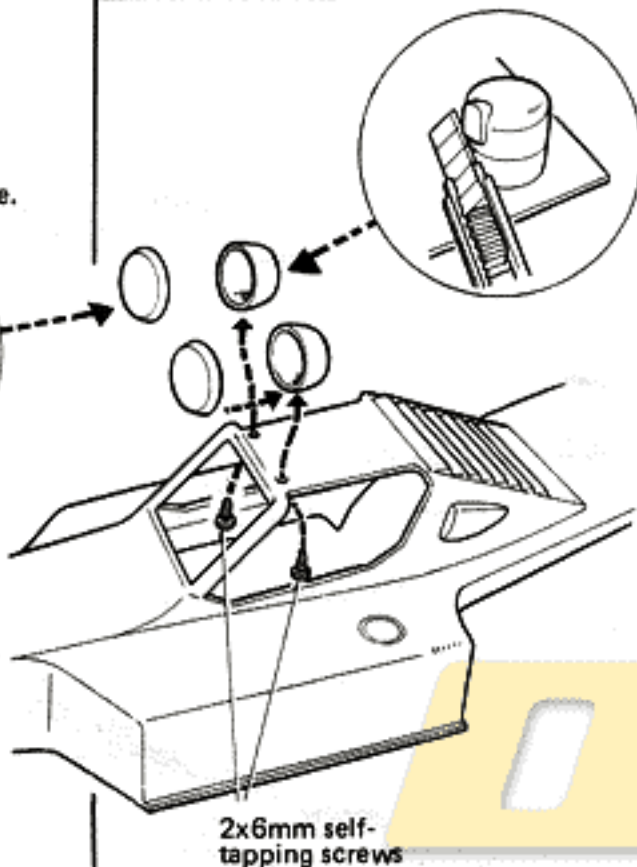

2x6mm self-tapping screws

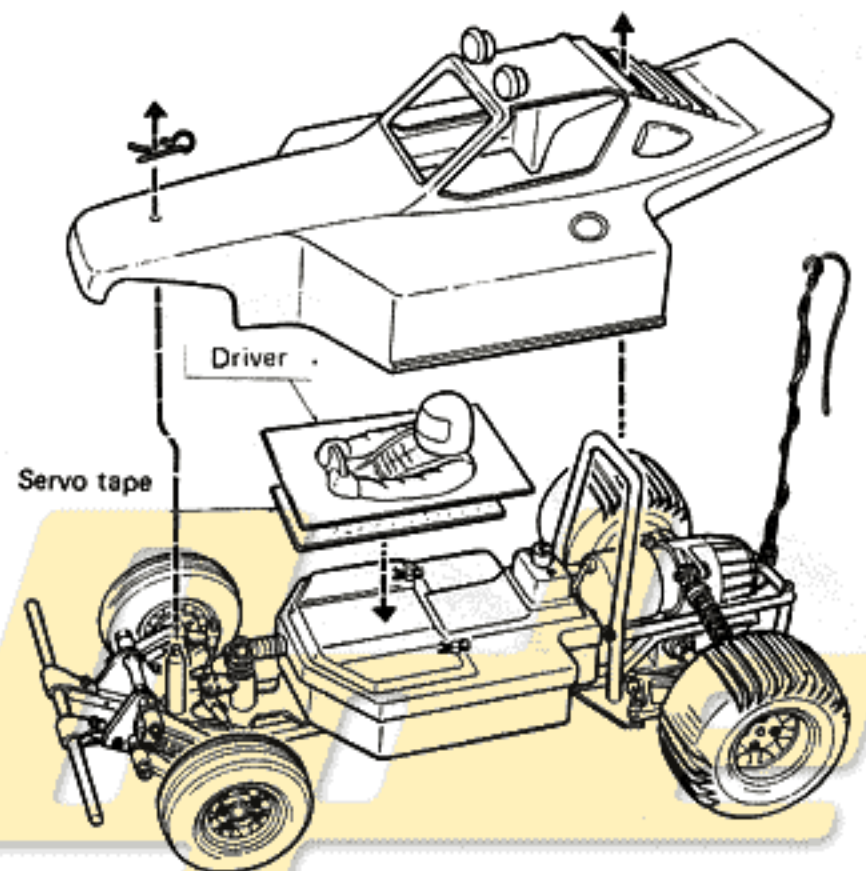

Driver

Servo tape

32 MOUNTING THE BODY

Check the wheel well cut-outs for proper tire clearance.



Body pin

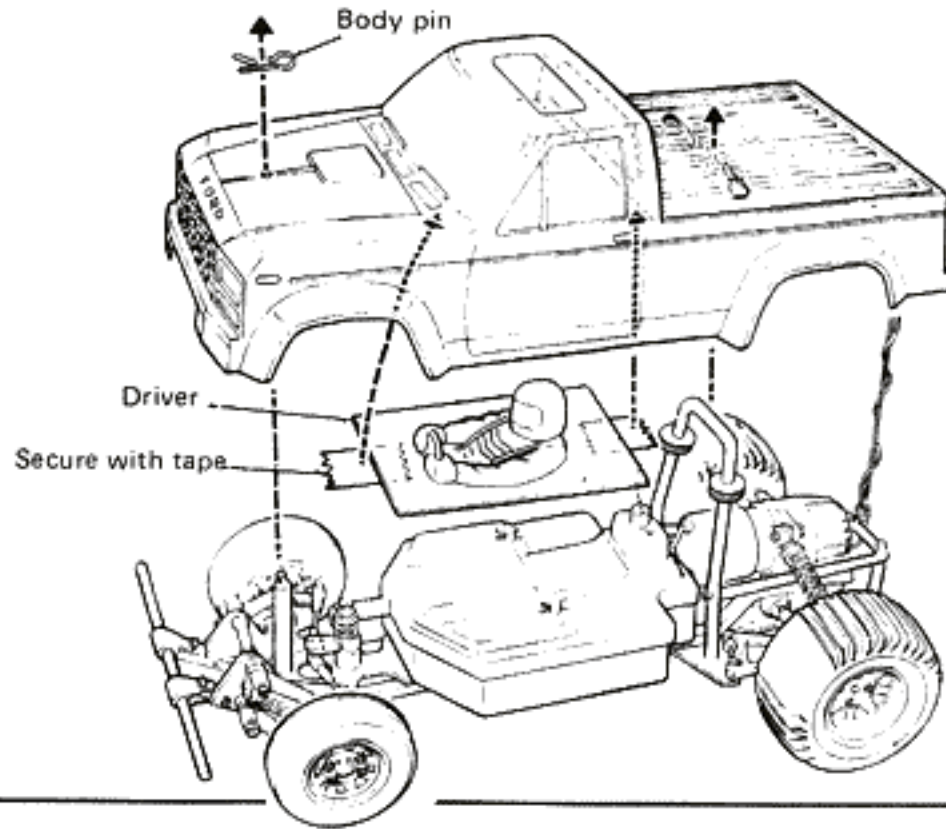

IMPORTANT PRECAUTIONS!

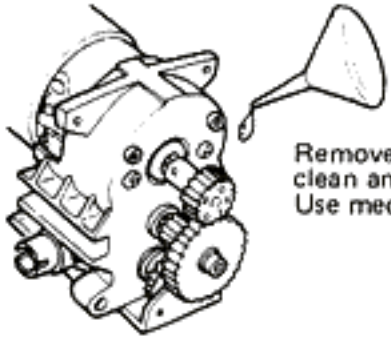

Remove gearbox cover and clean and oil gears frequently. Use medium grade gear lube.



Check suspension and half-shafts for weeds and other debris that can become lodged in them.

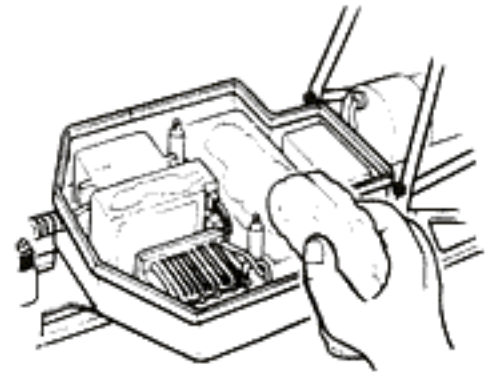

Use a cloth or brush to remove dust and dirt after each running.

Periodically check all screws and nuts to make sure that they are secure.



Check all wiring insulation.

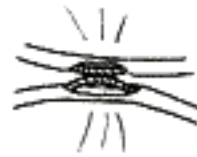











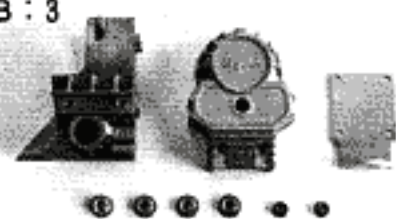

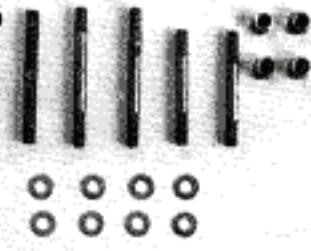
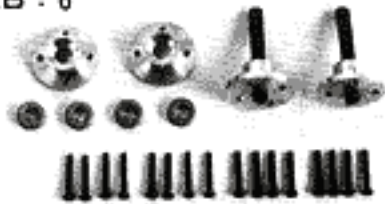



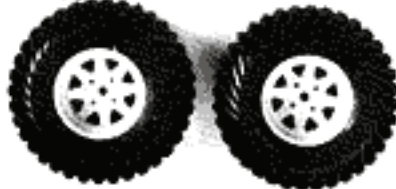



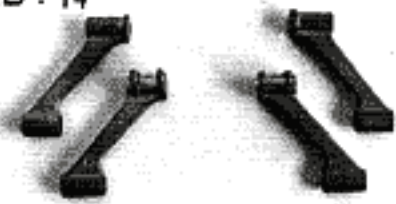
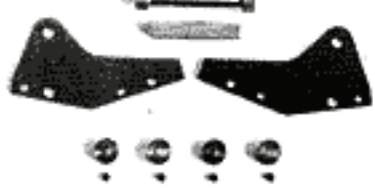



THE AYK SUPER TRAIL RACING TEAM.

Your completed AYK Super Trail can compete in the ORRCA stock class with restricted modification and the Mabuchi RS540 motor. Ball bearings and machined gears are also legal, and there is a limit of 6 cells (7.2v). There are also Modified and Open classes which allow elaborate modifications, rewind motors and unlimited battery packs.

Because the Super Trail is designed for optimum off-road competition it is subject to AYK's continuing development program. Therefore, minor component changes from these instructions may occur. Please refer to supplements for this information.

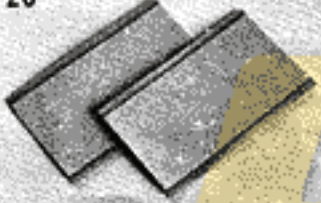

<p>RB : 1</p>  <p>Chassis frame rails</p>	<p>RB : 2</p>  <p>Radio Case</p>	<p>RB : 3</p>  <p>Gearbox w/bearings</p>	<p>RB : 4</p>  <p>Front bumper kit</p>
<p>RB : 5</p>  <p>Front suspension extender set</p>	<p>RB : 6</p>  <p>Front and rear hub set</p>	<p>RB : 7</p>  <p>Front shock set</p>	<p>RB : 8</p>  <p>Front tire and wheel set</p>
<p>RB : 9</p>  <p>Rear shock set</p>	<p>RB : 10</p>  <p>Rear tire and wheel set</p>	<p>RB : 11</p>  <p>3mm ball bearings</p>	<p>RB : 12</p>  <p>4mm ball bearings</p>
<p>RB : 13</p>  <p>Rubber sealing set (motor and switch covers, radio case gasket, grommets)</p>	<p>RB : 14</p>  <p>Front suspension arms</p>	<p>RB : 15</p>  <p>Side plate set w/collars</p>	<p>RB : 16</p>  <p>Ball joint set (4)</p>
<p>RB : 17</p>  <p>Steering arm set</p>	<p>RB : 18</p>  <p>16T . brass pinion</p>	<p>RB : 19</p>  <p>18T . brass pinion</p>	<p>RB : 20</p>  <p>27Tx10 . brass idler gear</p>
<p>RB : 21</p>  <p>29Tx10 . brass idler gear</p>	<p>RB : 22</p>  <p>20T . brass idler gear</p>	<p>RB : 23</p>  <p>10T Machined bevel pinion</p>	<p>RB : 24</p>  <p>20T Machined bevel drive gear</p>
<p>RB : 25</p>  <p>Speed controller set</p>	<p>RB : 26</p>  <p>Servo tape</p>	<p>RB : 27</p>  <p>Drive joint/half shaft set</p>	<p>RB : 28</p>  <p>Rear trailing link set</p>

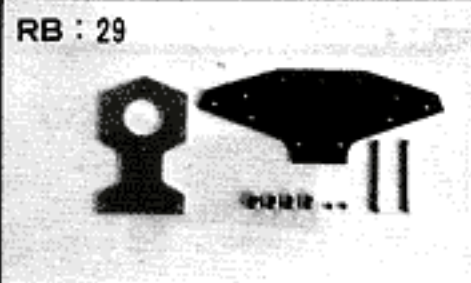

RB : 29

Front and rear plate set

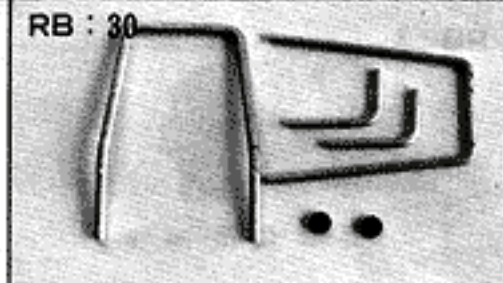

RB : 30

Roll bar, bumper and guards

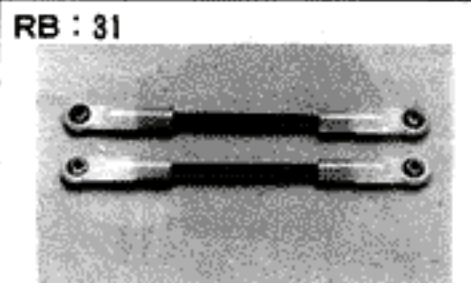

RB : 31

Threaded rods and ball joints

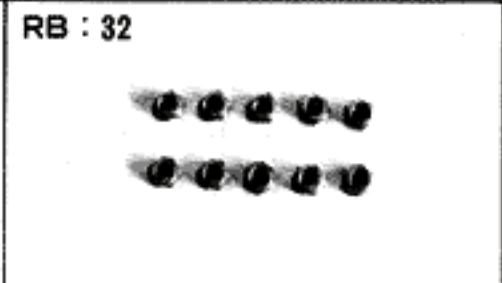

RB : 32

2mm machine nuts

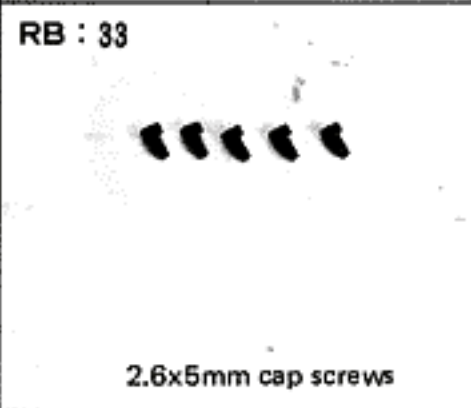

RB : 33

2.6x5mm cap screws

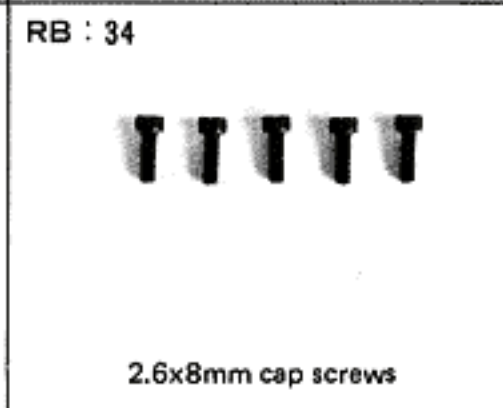

RB : 34

2.6x8mm cap screws

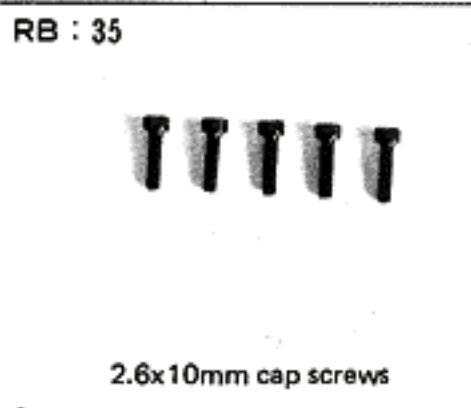

RB : 35

2.6x10mm cap screws

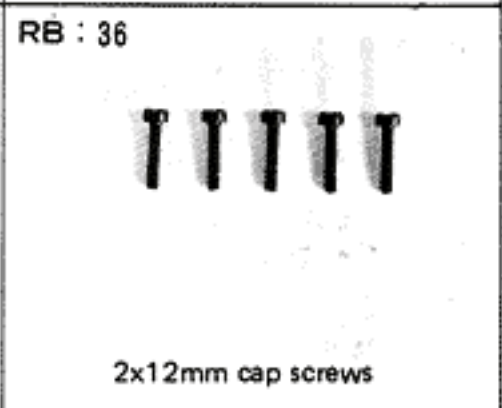

RB : 36

2x12mm cap screws



RB : 37

Baja Bison body shell



RB : 38

Ford 4x4 body shell

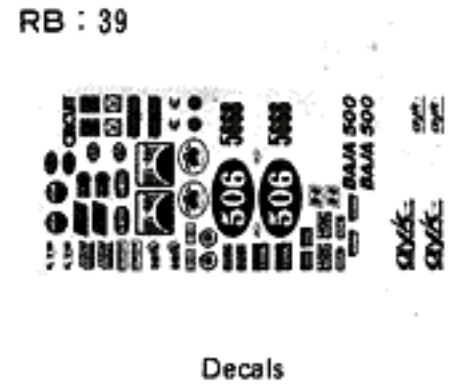

RB : 39

Decals



RB : 40

Baja Bison body post

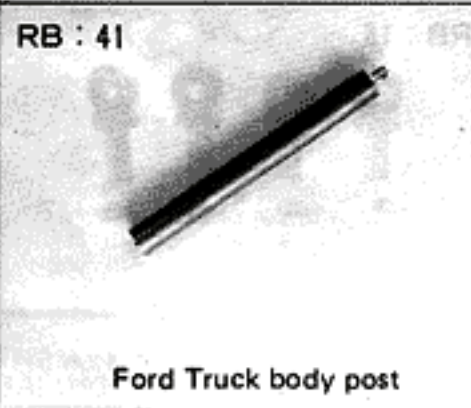

RB : 41

Ford Truck body post

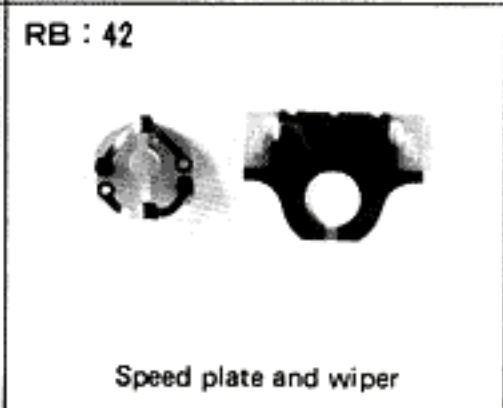

RB : 42

Speed plate and wiper

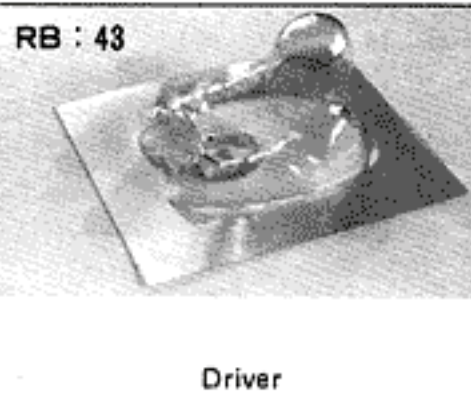

RB : 43

Driver

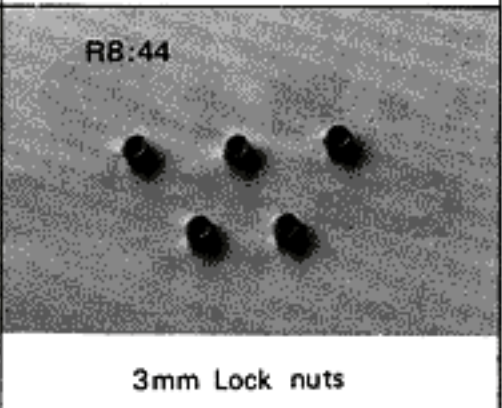

RB:44

3mm Lock nuts

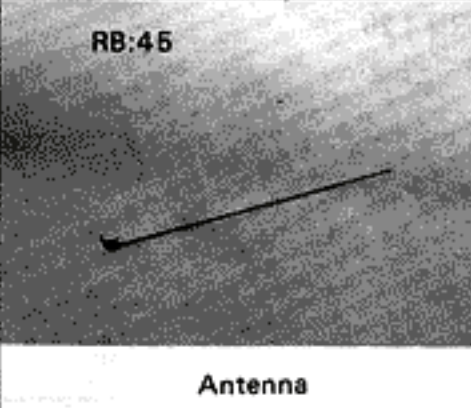

RB:45

Antenna

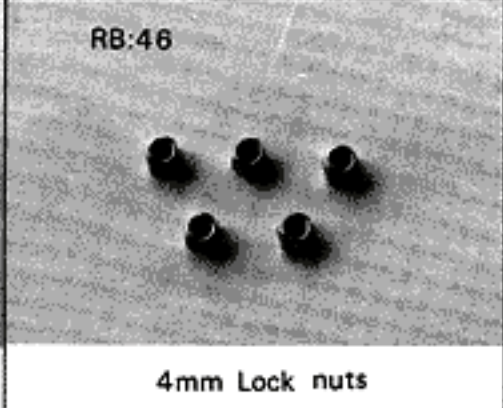

RB:46

4mm Lock nuts

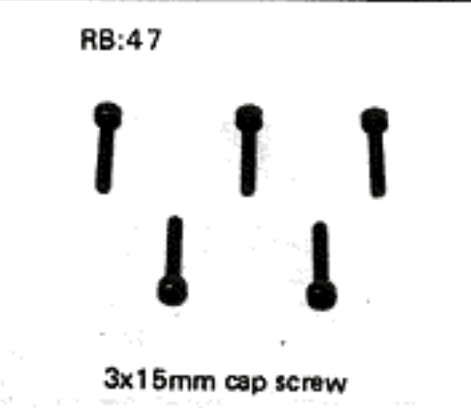

RB:47

3x15mm cap screw

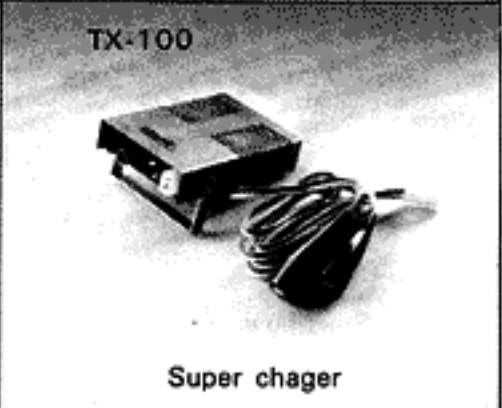

TX-100

Super charger

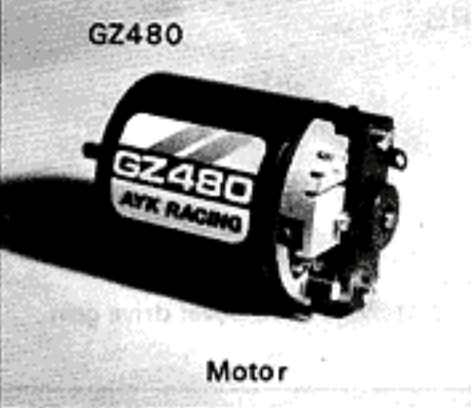

GZ480

Motor



GS1200

7.2v/1200mAh NiCad pack



AOYAGI METALS CO., LTD.
AOYAGI METALS CO., LTD.
 5-22-7 Kita-koiwa Edogawa-ku Tokyo, Japan 〒133 MADE IN JAPAN